

Unità Aggregata / Aggregate Unit:
Codice/Code:

Fast Line Four ER25 H145
FL.FOUR.00/145L63F-H1

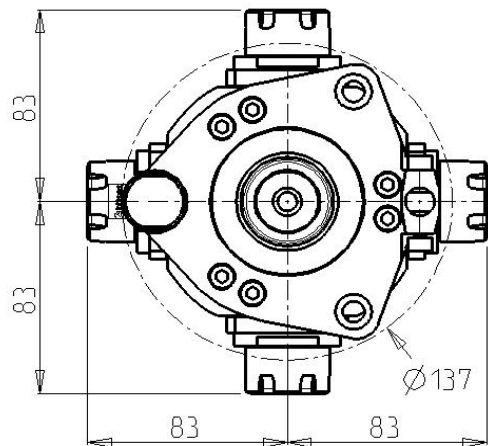
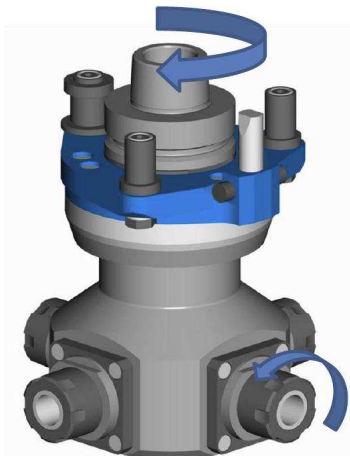
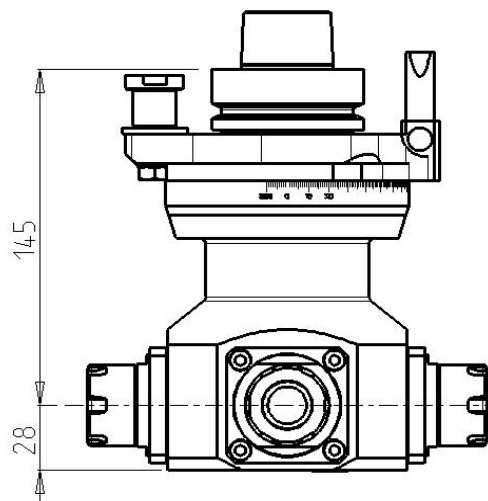
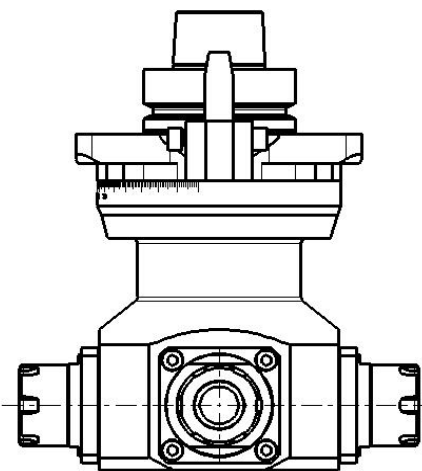

Specifiche tecniche / Technical specifications

Velocità rotazione mandrino / Spindle speed	10850 rpm max *
Velocità rotazione utensile / Tool speed	15500 rpm max *
Rapporto di trasmissione / Gear ratio	1:1.43
Attacco mandrino / Spindle coupling	** HSK 63F
Attacco utensile / Tool coupling	4 x ER 25
Diametro codolo / Tool shank diameter	1 – 16
Diametro punta max / Max bit diameter	16
Diametro lama / Blade diameter	/
Peso / Weight	6,5 kg
Lubrificazione / Lubrication	grasso / grease
Temperatura / Temperature	75 °C / 167 F max
Orientamento angolare / aggregate rotation	0 – 360° in continuo / continuous
Connessione asse C / C axis connection type	** Hiteco 1 (schema 29L0061161G)

* vedere manuale / see user manual

** altre versioni disponibili / other connections available