

LAYOUT

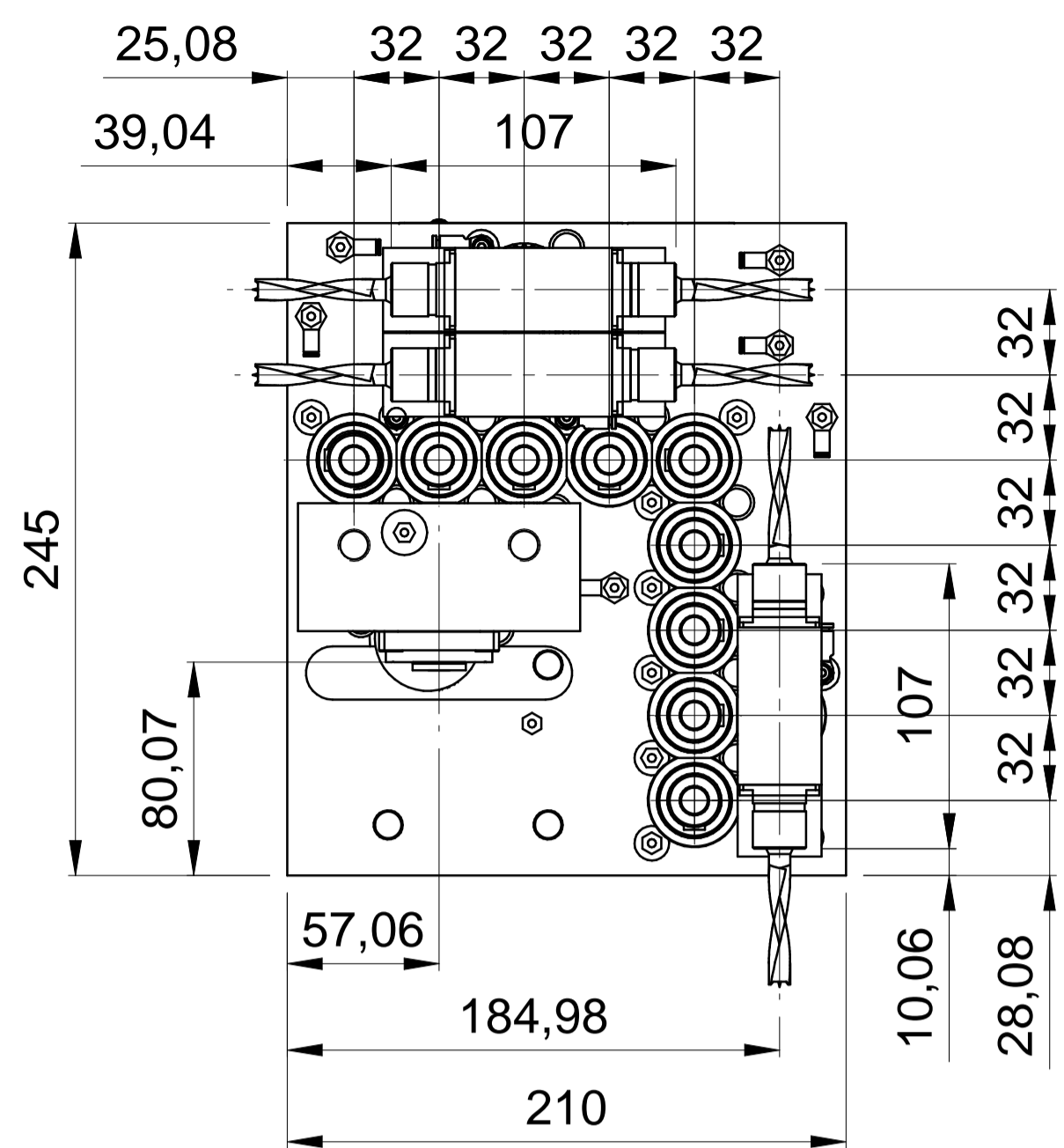

SENSO DI ROTAZIONE MOTORE ORARIO (DX)
(senso rotazione motore e mandrini visto da sopra, lato motore)

MOTOR ROTATION CW (RH)
(direction of rotation of motor and spindles seen from above, motor side)

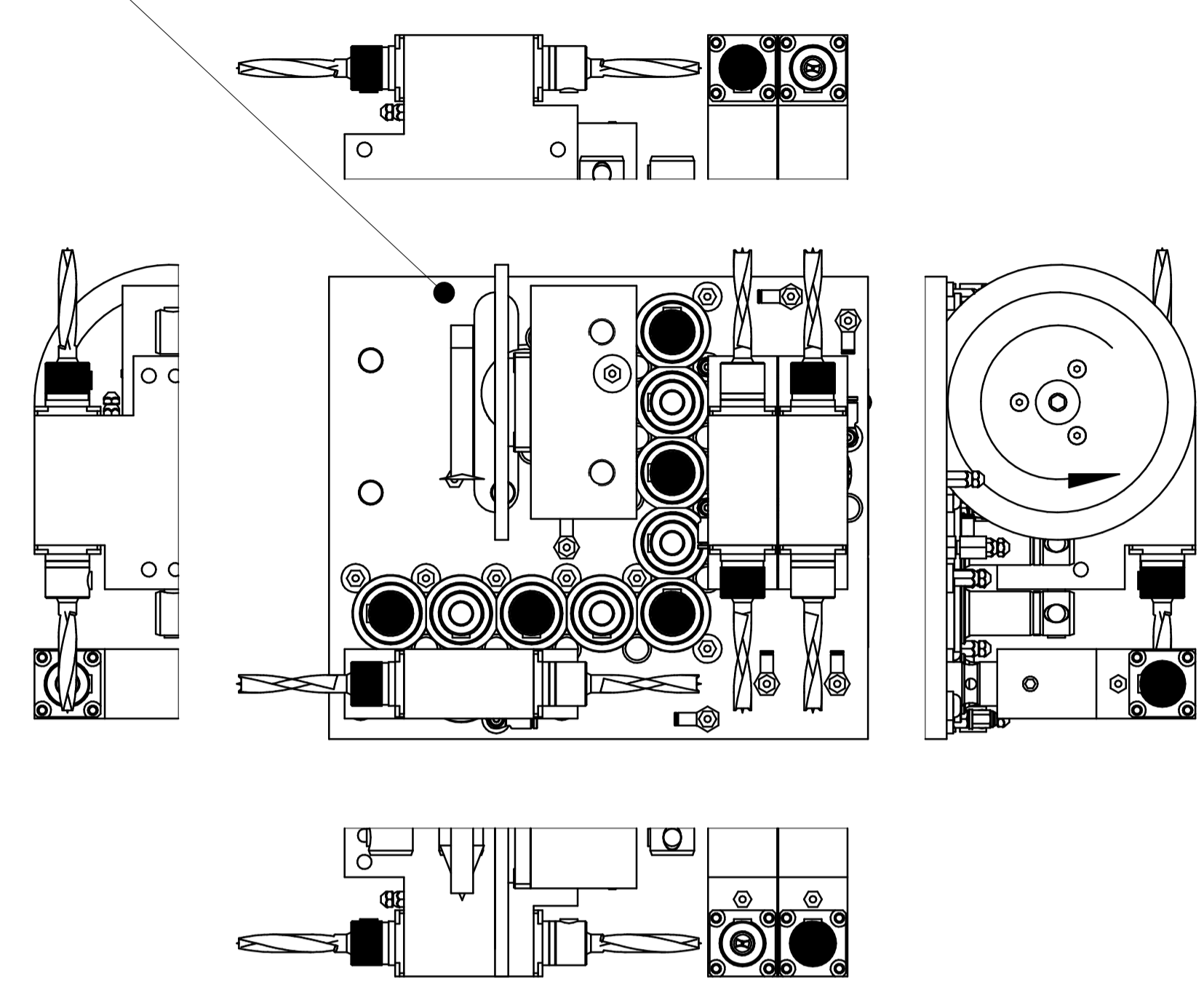

- ROTAZIONE DESTRA / RIGHT ROTATION
- ROTAZIONE SINISTRA / LEFT ROTATION
- ROTAZIONE DESTRA / RIGHT ROTATION
- ROTAZIONE SINISTRA / LEFT ROTATION

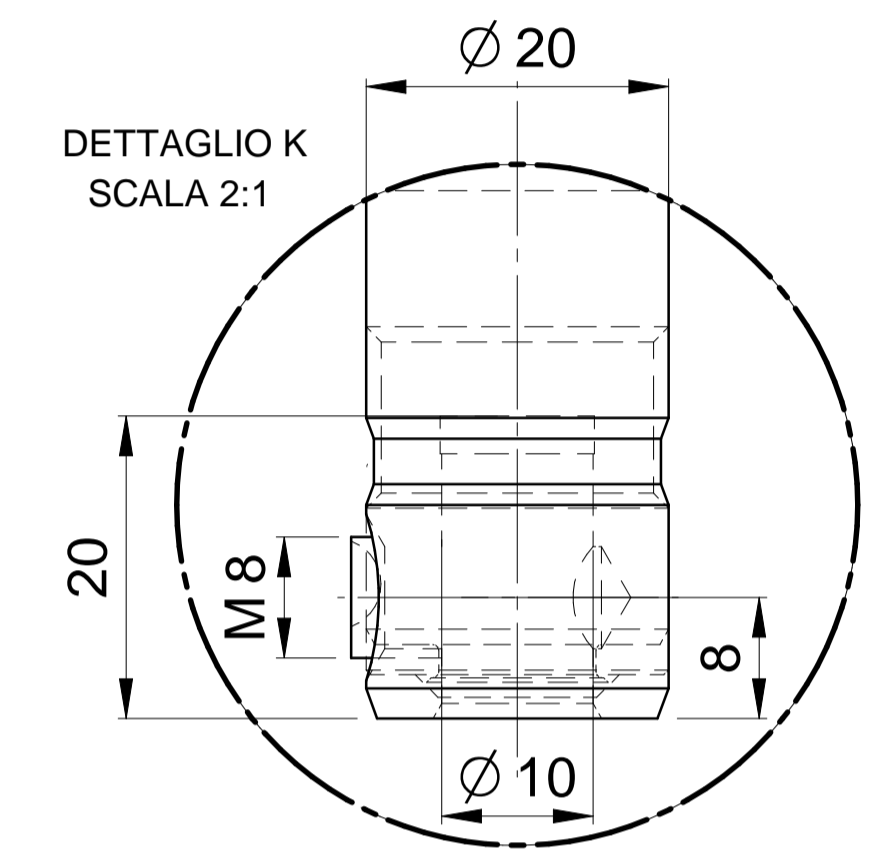

VERTICAL AND HORIZONTAL SPINDLE

CARATTERISTICHE TECNICHE / TECHNICAL FEATURES

MANDRINI VERTICALI / VERTICAL SPINDLES	9
MANDRINI ORIZZONTALI / HORIZONTAL SPINDLES	3
LAMA / BLADE SPINDLE	1
ATTACCO PUNTE / TOOL CONNECTION	10 H7 mm
INTERASSE PUNTE /DISTANCE BETWEEN CENTERS	32 mm
MAX LUNGHEZZA PUNTE / MAX BORING BITS LENGHT	70 mm
DIMENSIONE LAMA / BLADE DIMENSION	ø125
CENTRAGGIO LAMA / BLADE SHAFT	ø20 g6
CORSA MANDRINI VERTICALI / VERTICAL SPINDLES STROKE	60 mm (SINGLE EFFECT CYLINDER)
CORSA MANDRINI ORIZZONTALI / HORIZONTAL SPINDLES STROKE	75 mm (DOUBLE EFFECT CYLINDERS)
CORSA GRUPPO LAMA / BLADE UNIT STROKE	60 mm (DOUBLE EFFECT CYLINDERS)
SPINTA VERTICALE MANDRINI / VERTICAL SPINDLES THRUST	335 N (6 bar) - 550 N (9 bar)
POTENZA MOTORE / MOTOR POWER	1,7 kW
TENSIONE NOMINALE /RATED VOLTAGE	230 / 380 V
CORRENTE NOMINALE / RATED CURRENT	6,1 A / 3,5 A
VELOCITA' ROTAZIONE MOTORE / MOTOR RATED SPEED	2770 RPM (50 Hz)
SENSO DI ROTAZIONE MOTORE / MOTOR ROTATION	DESTRO / RIGHT
FREQUENZA NOMINALE / RATED FREQUENCY	50 Hz
COS f	0,72
ALIMENTAZIONE MOTORE / ELECTRICAL SUPPLY	50 Hz / 25-95 Hz
RAPPORTO DI TRASMISSIONE /SPEED RATIO (SPINDLES/MOTOR)	1,5
ROTAZIONE VERTICALI / VERTICAL SPINDLES SPEED	4000 RPM / 2000-8000 RPM
ROTAZIONE ORIZZONTALI / HORIZONTAL SPINDLES SPEED	4000 RPM / 2000-8000 RPM
RAPPORTO DI TRASMISSIONE /SPEED RATIO BLADE/MOTOR	1,8
ROTAZIONE LAMA / BLADE SPEED	5000 RPM / 2500-10000 RPM
LUBRIFICANTE / LUBRICATOR (VEDI MANUALE/SEE USER MANUAL)	GREASE KLUEBER ISO FLEX NBU15
PESO / WEIGHT	50 kg

BLADE SPINDLE

