

Elettromandrino / electrospindle

QX-2 10/12 24 63F NC

Codice / Code:

QX.X00.L02.00

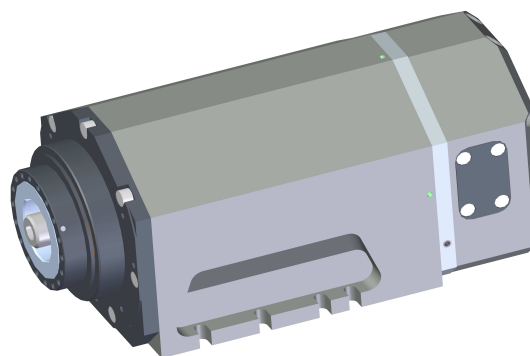

Prestazioni - Performances

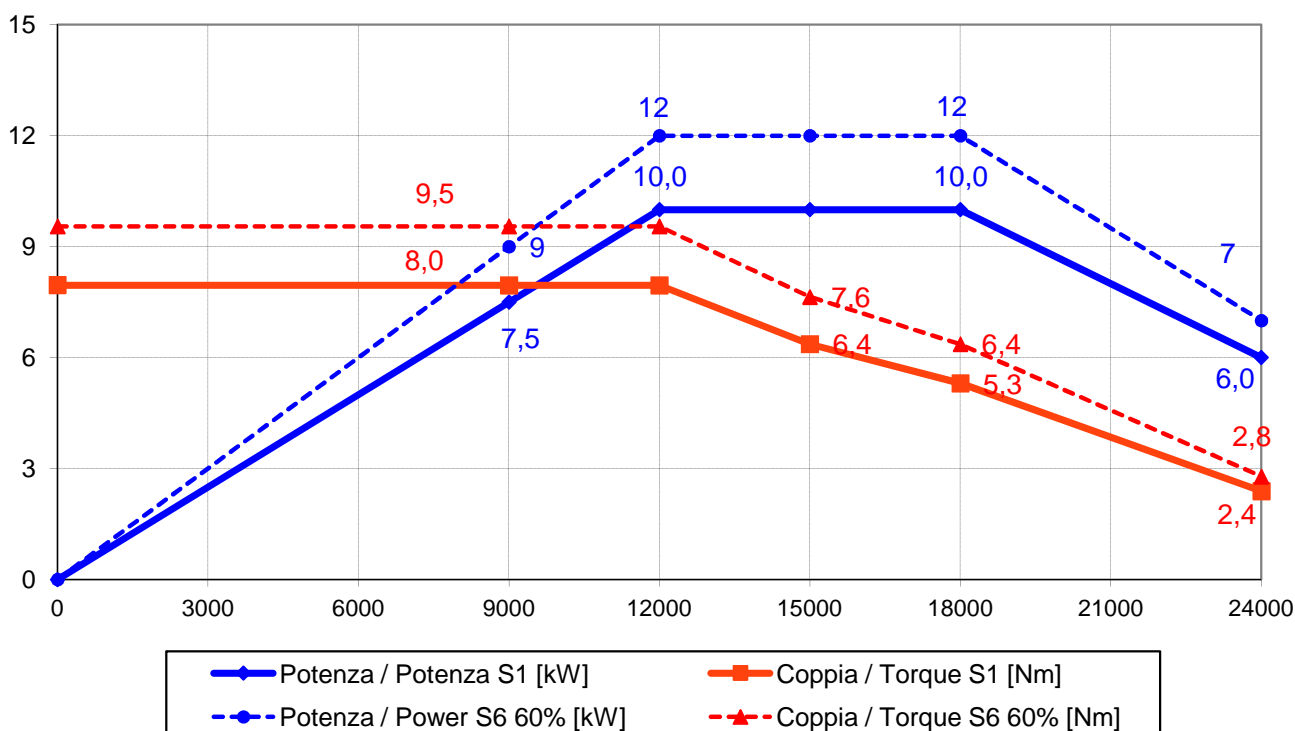

Specifiche tecniche / Technical specifications	
Potenza max. (serv. S1) / Max. Power.(S1 duty)	10 kW @ 12000 Rpm
Coppia max. (serv. S1) / Max. Torque (S1 duty)	8,0 Nm
Corrente (serv. S1) / Current (S1 duty)	23 A
Potenza max. (serv. S6 60%) / Max. Power.(S6 60% duty)	12 kW @ 12000 Rpm
Coppia max. (serv. S6 60%) / Max. Torque (S6 60% duty)	9,5 Nm
Corrente (serv. S6 60%) / Current (S6 60% duty)	26 A
Tensione / Voltage	380 V
Numero poli / Poles	4
Velocità rotazione max / Max Speed	24 000 Rpm
Rotazione / Rotation	CW - CCW
Azionamento / Supply	con inverter / by inverter
Attacco utensile / Tool interface	HSK 63F
Raffreddamento / Cooling	a liquido mediante scambiatore di calore/ liquid by heat exchanger
Raffreddamento / Cooling	S1 Afferraggio utensile / Tool lock
	S2 Pinza aperta / Tool released
	S3 Rotazione albero / Spindle rotation
Pressione impianto pneumatico / Pneumatic system pressure	10,5 - 11,5 bar
Peso / Weight	18 kg