

**ATTACCO HSK 63F DIN 69893-6
TOOL INTERFACE HSK 63F DIN 69893-6**

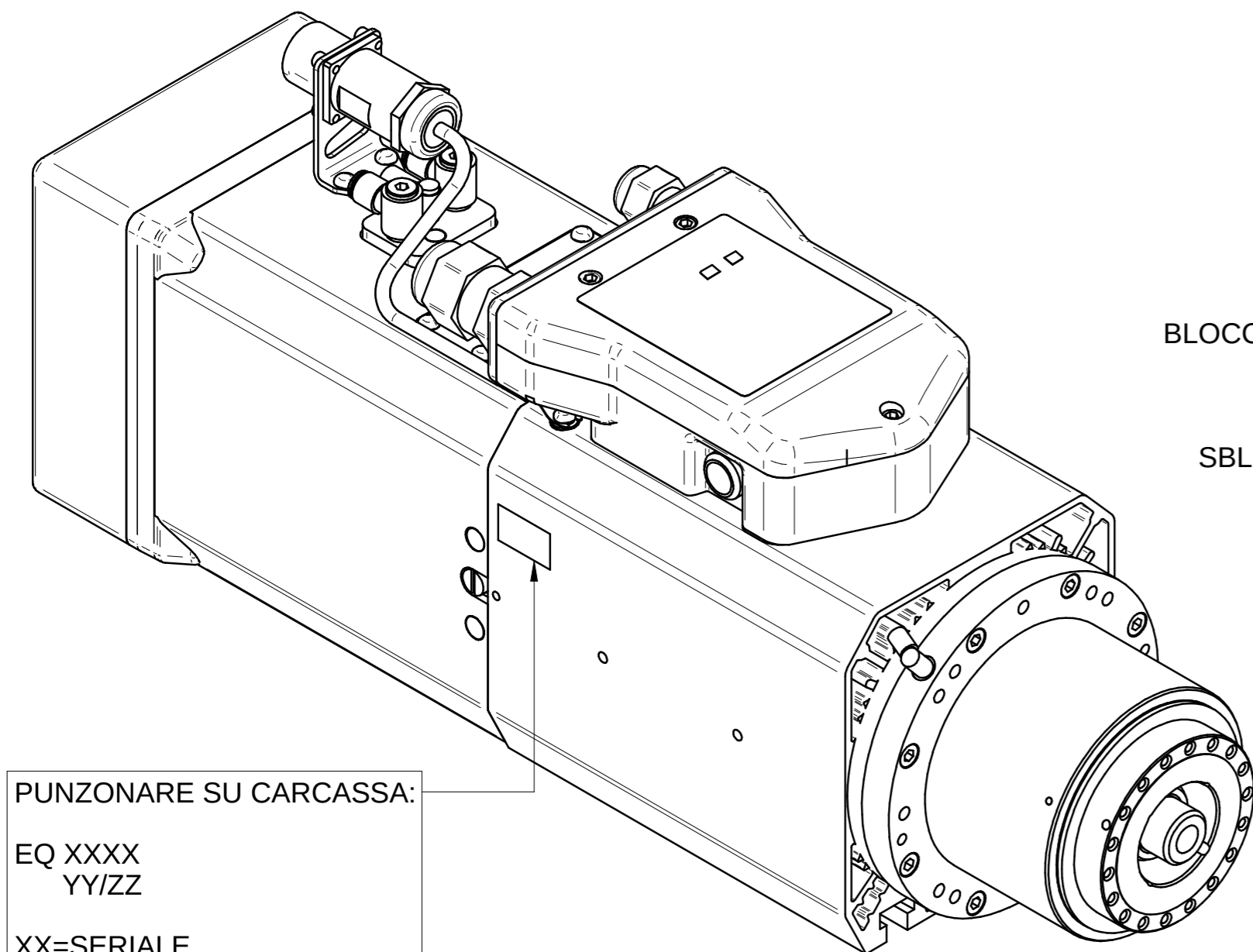

PUNZONARE SU CARCASSA:
EQ XXXX
YY/ZZ

XX=SERIALE
YY=MESE DI PROD.
ZZ=ANNO DI PROD.

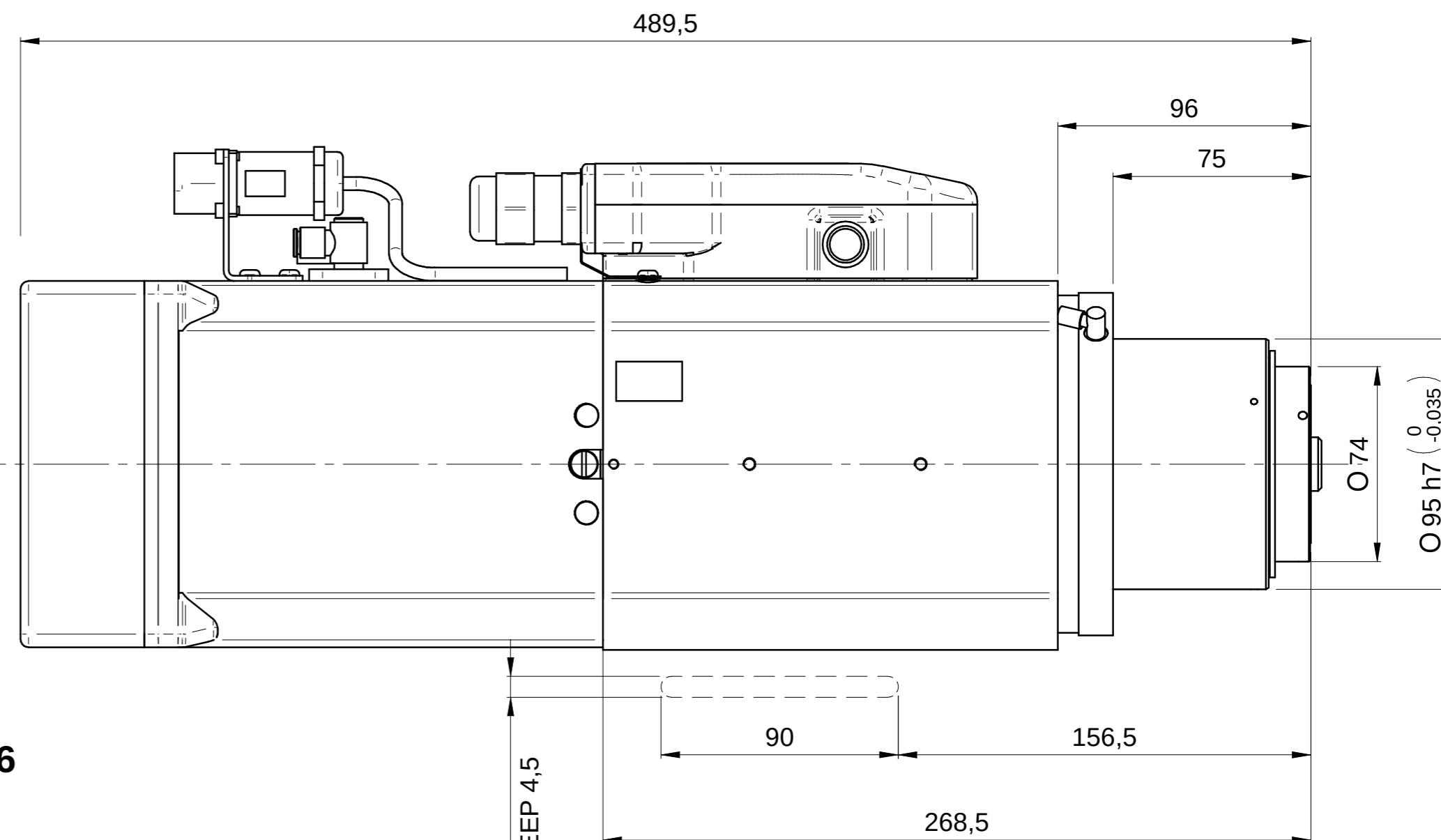

PRESSACAVO MET.M16 DIR. X EMC
METALLIC GLAND M16 STRAIGHT FOR EMC

SOFFIO CONO: E6 ARIA SECCA 6 BAR
TAPER CLEANING: E6 AIR DRY 6 BAR

CONNETTORE CIRCOLARE
M23 SEGNALE 17 VIE
CIRCULAR CONNECTORS
M23 SIGNAL 17 CONTACTS

BLOCCO UTENSILE: E4 ARIA SECCA 6 BAR
LOCK TOOL: E4 AIR DRY 6 BAR

SBLOCCO UTENSILE: E6 ARIA SECCA 6 BAR
RELEASE TOOL: E6 AIR DRY 6 BAR

PRESSACAVO MET.M25 DIR. X EMC
METALLIC GLAND M25 STRAIGHT FOR EMC

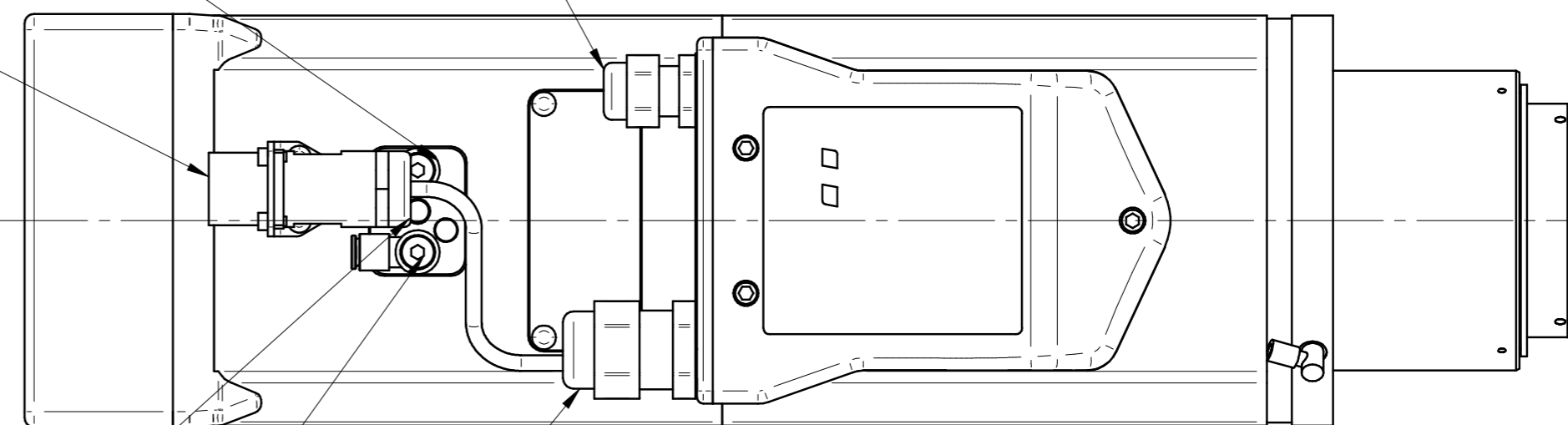

MASSA MASS: 25 Kg

02									
01									
Rev	Data / Date	Firma / Signature	Descrizione ultima modifica / Last change description			N° Modifica / Change ID			
<small>Caratteristiche tecniche non evidenziate secondo istruzioni operative SCM GROUP : IO 231D1TG Specificazioni not shown according to SCM GROUP operation instruction : IO 231D1TG Struttura saldata secondo specifica SCM / Welded according to SCM specific : ST232D1G Futuro secondo specifica SCM / Mergers secondo SCM specific : ST233D1G Quote senza indicazione di tolleranza, grado di precisione Shares without indication of tolerance, accuracy</small>						SCM Specifica ST2310DTG Trattamento Superficiale / Surface Treatment (SCM specific ST234D1G)		Verniciatura / Painting (SCM specific ST231D1TG) VER000 Superficie / Surface (m²)	
Ultimo rilascio Latest release						Trattamento Termico / Heat Treatment (SCM specific ST234D1TG)			
Controllato Checker						CF3 0 0 Smussi / chamfer		Peso grezzo/Raw weight (kg) Ricavare da o Stato di fornitura / Based on or State of supply	
Disegnato Designed L.Guiducci						Data / Date 09/07/2014		Massa / Mass (kg) 24,105	
HITECO HIGH TECHNOLOGY COMPONENTS						Denominazione / Item Name ELETM QE-1F 8/12 24 63F NC CB DV EN			
Template version: 14						Scala / Scale 1:2		Codice / Item ID QE.300.A10.00	
CI RISERVIAMO A TERMI DI LEGGE LA PROPRIETA DI QUESTO DISEGNO CON DIVIETO DI RENDERSILO COMEQUE NOTO A TERZI SENZA LA NOSTRA PREVENTIVA APPROVAZIONE. DRAWING IS SCM-PROPERTY. COPYRIGHTED MATERIAL. DISCLOSURE TO THIRD PARTIES WITHOUT OUR AUTHORISATION IS EXPLICITLY FORBIDDEN.						Rev 02		Status 1/1	