

**ATTACCO HSK 63F DIN69893-6  
TOOL INTERFACE HSK 63F DIN 69893-6**

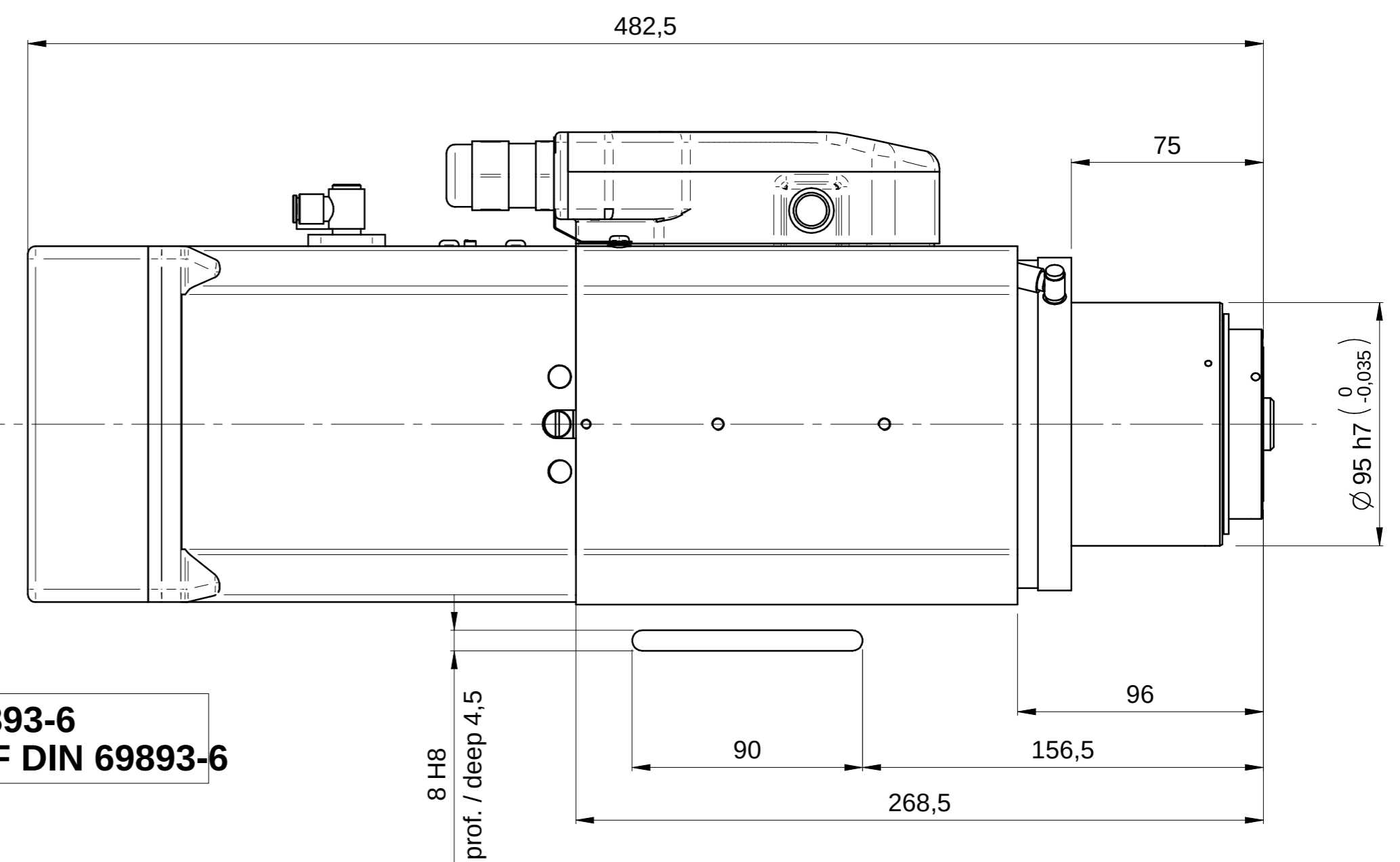

0001351316H PRESSACAVO MET.M16 DIR. X EMC  
METALLIC GLAND M16 STRAIGHT FOR EMC

SOFFIO CONO: E6 ARIA SECCA 6 bar  
TAPPER CLEANING EG AIR DRY 6 bar

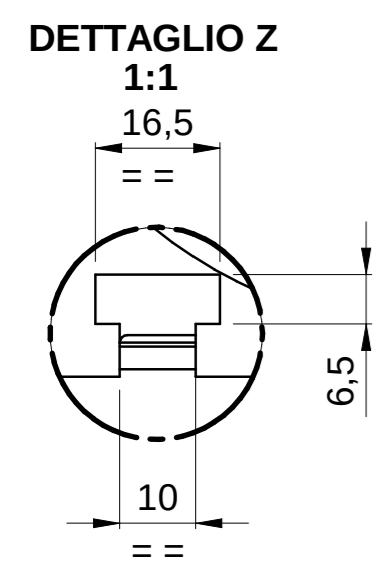
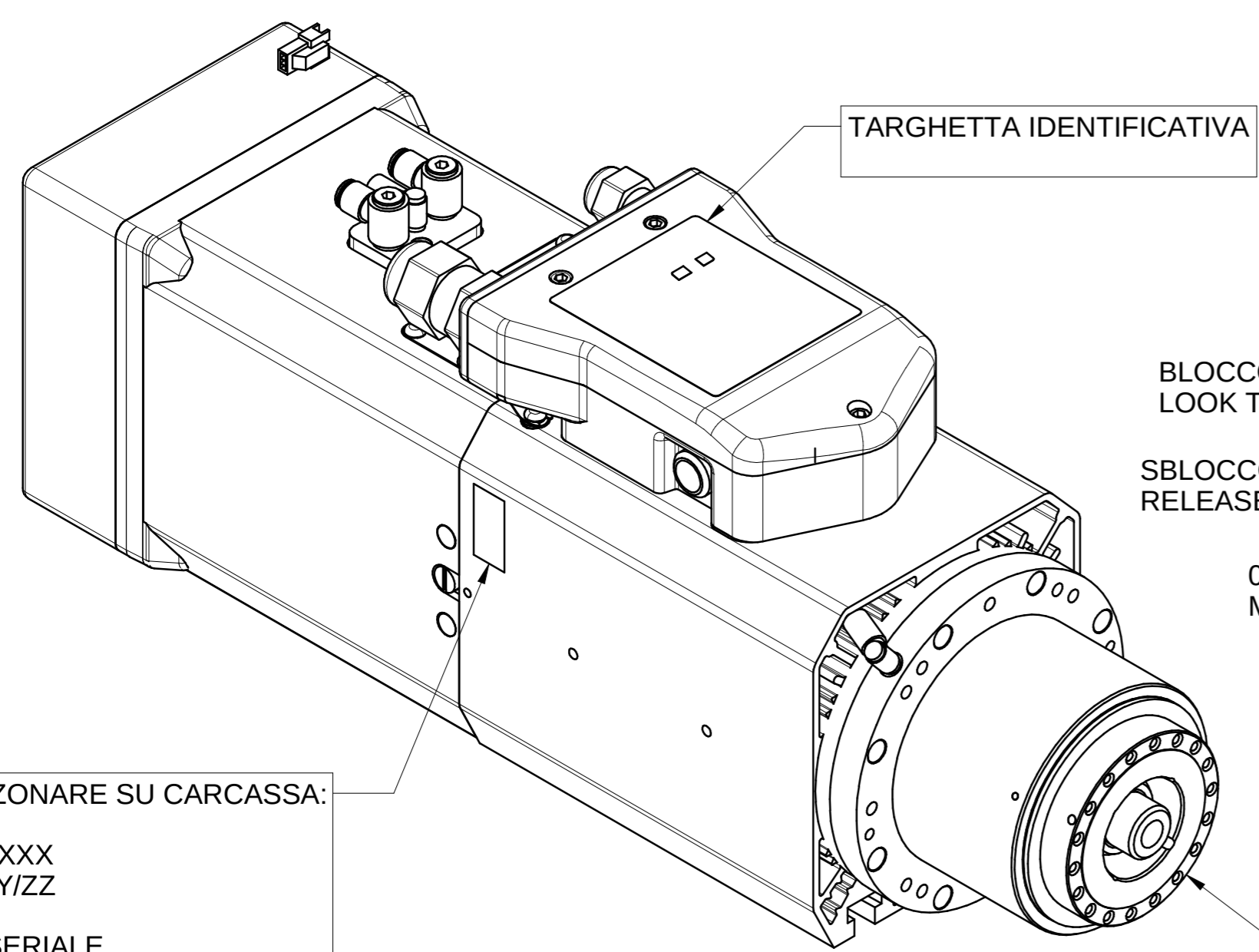

TARGHETTA IDENTIFICATIVA

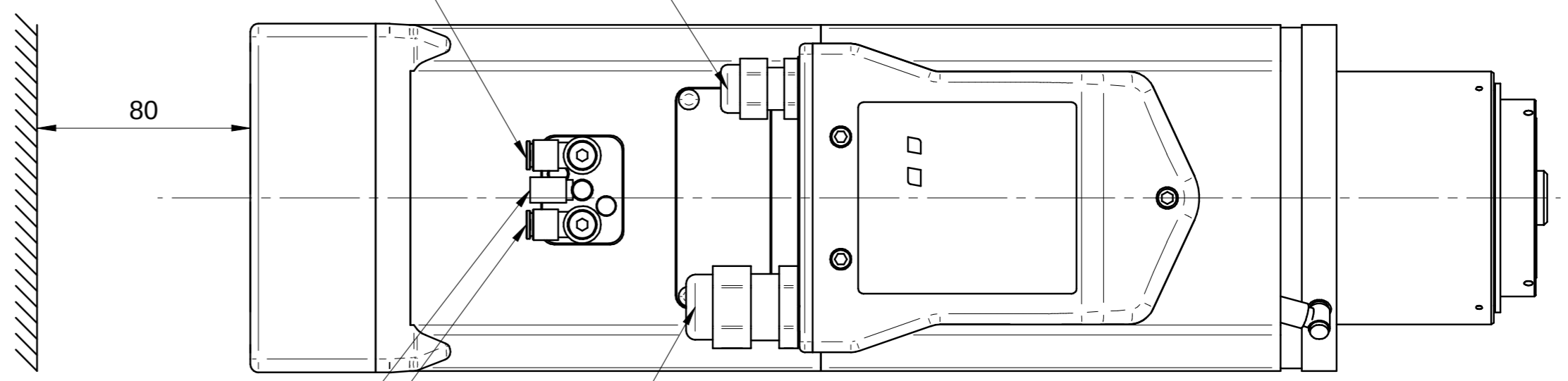

BLOCCO UTENSILE: E4 ARIA SECCA 6 bar  
LOOK TOOL : E4 AIR DRY 6 bar

SBLOCCO UTENSILE: E6 ARIA SECCA 6 bar  
RELEASE TOOL: EG AIR DRY 6 bar

0001351317A PRESSACAVO MET.M25 DIR. X EMC  
METALLIC GLAND M25 STRAIGHT FOR EMC

**Massa: 23 Kg**

ELETTROMANDRINO

**PUNZONARE SU CARCASSA:**  
EQ XXXX  
YYZZ  
  
XX=SERIALE  
YY=MESE DI PRODUZIONE  
ZZ=ANNO SI PRODUZIONE

00										
Rev	Data / Date	Firma / Signature	Descrizione ultima modifica / Last change description		N° Modifica / Change ID					
<small>Caratteristiche tecniche non evidenziate secondo istruzioni operative SCM GROUP : IO 231D1TG          Specifications not shown according to SCM GROUP operation instruction : IO 231D1TG          Struttura saldate secondo specifica SCM / Welded according to SCM specific : ST232D1G          Futuro secondo specifica SCM / Material according to SCM specific : ST233D1G          Quote senza indicazione di tolleranza, grado di precisione Shares without indication of tolerance, accuracy</small>							<b>SCM Specifica ST2310DTG</b> Trattamento Superficiale / Surface Treatment ( SCM specific ST234DTG )		Verniciatura / Painting ( SCM specific ST231DTG ) <b>VER000</b> Superficie / Surface (m²)	
Ultimo rilascio / Latest release							Trattamento Termico / Heat Treatment ( SCM specific ST234DTG )			
Controllato / Checked							Peso grezzo / Raw weight (kg)		Ricavare da o Stato di fornitura / Based on or State of supply	
Disegnato / Designed <b>Fi.Fabrizi</b>							Smussi / chamfer <b>CF3</b>		Massa / Mass (kg) <b>23,776</b>	
Data / Date <b>26/11/2014</b>							Rugosità / Roughness		Materiale / Material ( SCM specific ST235DTG ) <b>Vedi Tabella</b>	
<b>HITECO</b> <small>HIGH TECHNOLOGY COMPONENTS</small>							Denominazione / Item Name <b>ELETM QE-1F 6.6/12 24 63F NC CB DV</b>		Scala / Scale <b>1:2</b>	
Template version: 15							Codice / Item ID <b>QE.300.A01.01</b>		Rev <b>00</b>	
CI RISERVIAMO A TERMI DI LEGGE LA PROPRIETA DI QUESTO DISEGNO CON DIVIETO DI RENDERSI COMUNIQUE NOTO A TERZI SENZA LA NOSTRA PREVENTIVA APPROVAZIONE. DRAWING IS SCM PROPERTY. COPYRIGHTED MATERIAL. DISCLOSURE TO THIRD PARTIES WITHOUT OUR AUTHORIZATION IS EXPLICITLY FORBIDDEN.							Status <b>1/1</b>		Tav. N. di N. <b>1/1</b>	