

# ORBITAL H

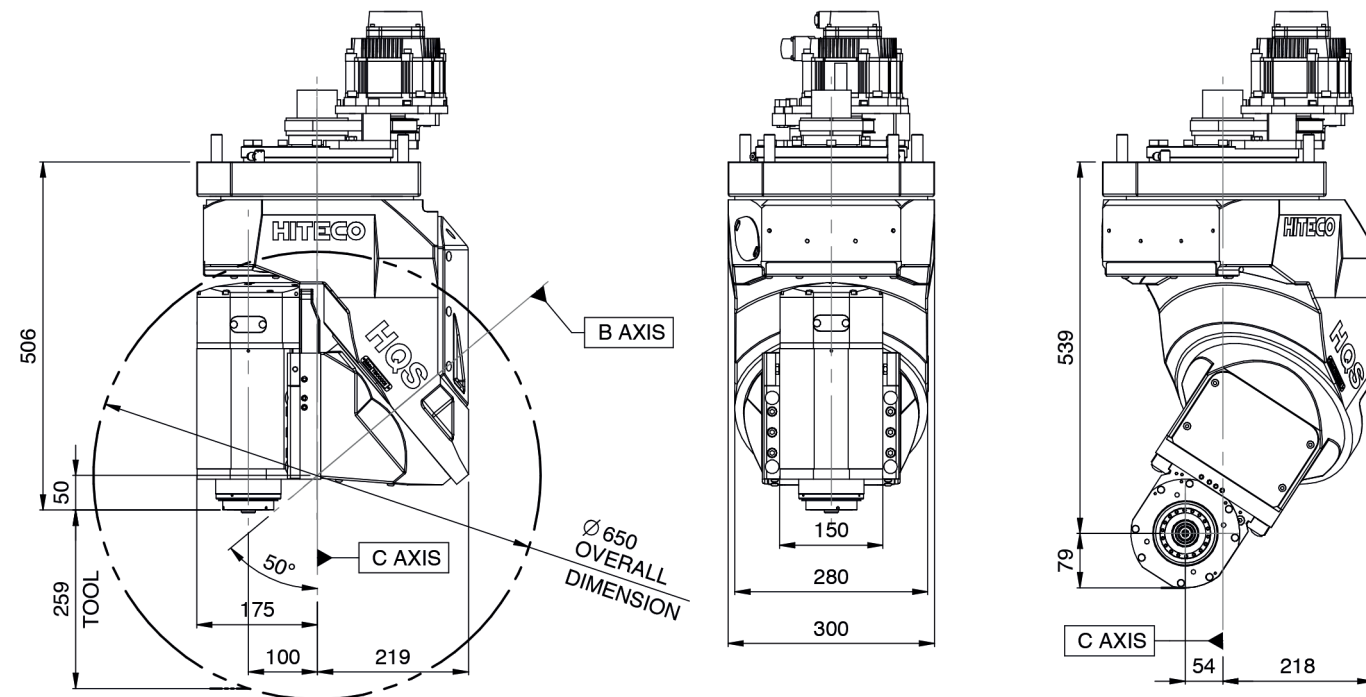

# ORBITAL H



MANDRINI DISPONIBILI ELECTROSPINDLES AVAILABLE

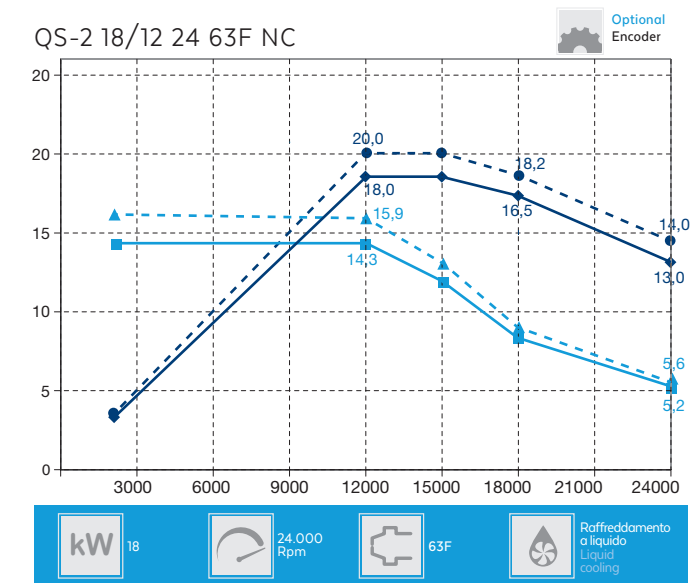
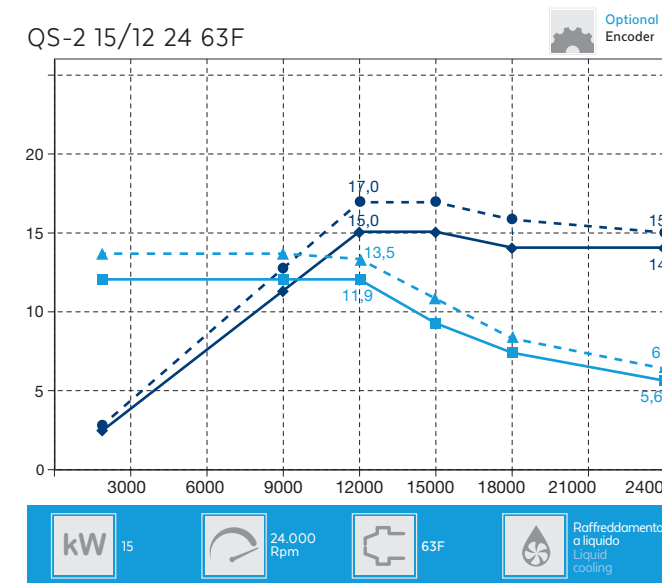

## SPECIFICHE TECNICHE TECHNICAL SPECIFICATIONS

	Asse B	Asse C
Servomotore <i>Servomotor</i>	Yaskawa*	Yaskawa*
Potenza servomotore <i>Servomotor power</i>	0,75 kW	0,85 kW
Encoder servomotore <i>Servomotor encoder</i>	Assoluto <i>Absolute 20 Bit</i>	Assoluto <i>Absolute 20 Bit</i>
Riduttore <i>Gearbox</i>	Sumitomo	Harmonic Drive
Coppia max continua <i>Max. continuous torque</i>	320 Nm	670 Nm
Coppia di picco <i>Peak torque</i>	740 Nm	980 Nm
Max rotazione asse <i>Max rotation axis</i>	±185°	±320°
Freni meccanici <i>Mechanical blocking axi</i>	Si <i>Yes</i>	Si <i>Yes</i>
Velocità posizionamento max <i>Max. positioning speed</i>	10.000°/'	11.500°/'
Velocità di lavoro max <i>Max operating speed</i>	4.500°/'	5.500°/'
Precisione di posizionamento assi <i>Precision positioning</i>	1 arcmin	1 arcmin
Peso <i>Weight</i>		140 kg

\*Sono disponibili altre marche di motorizzazioni a richiesta  
\*Other engines brands are available on demand

◆ Potenza Power S1 [kW]
 ■ Coppia Torque S1 [Nm]
 ◆ Potenza Power S6 60% [kW]
 ■ Coppia Torque S6 60% [Nm]