

# ORBITAL K

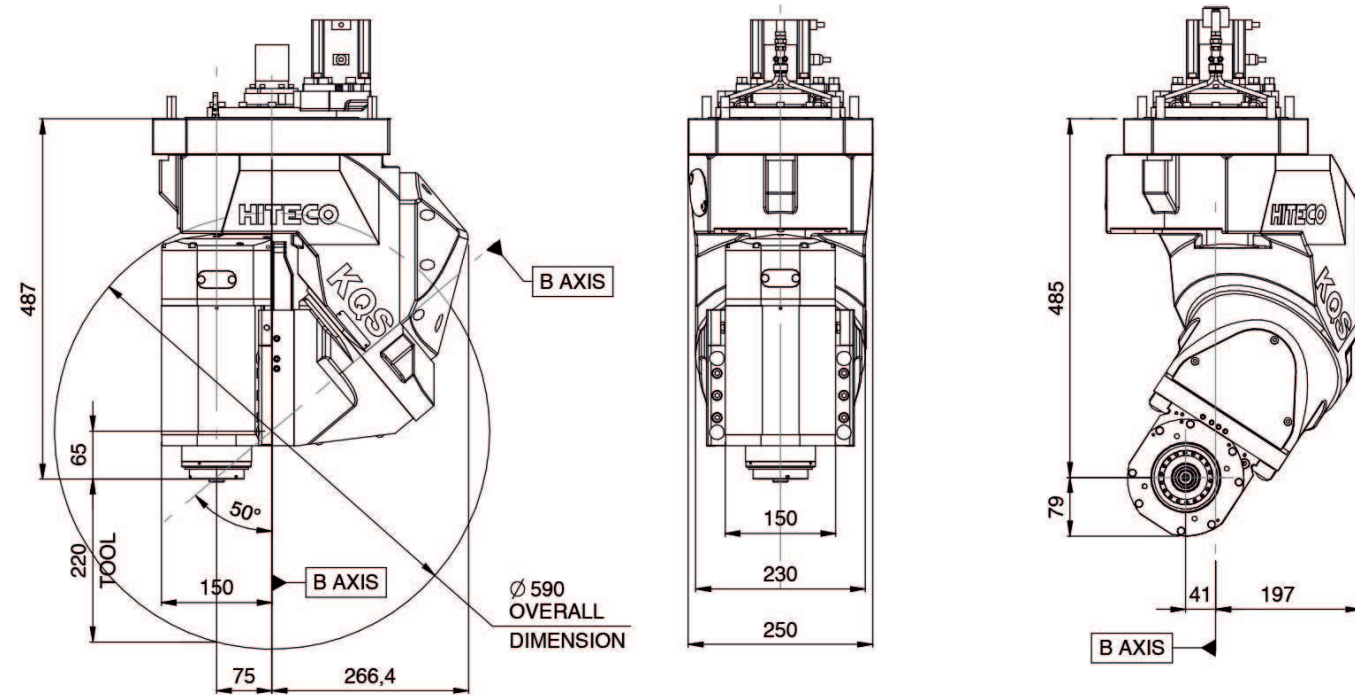

# ORBITAL K



MANDRINI DISPONIBILI ELECTROSPINDLES AVAILABLE

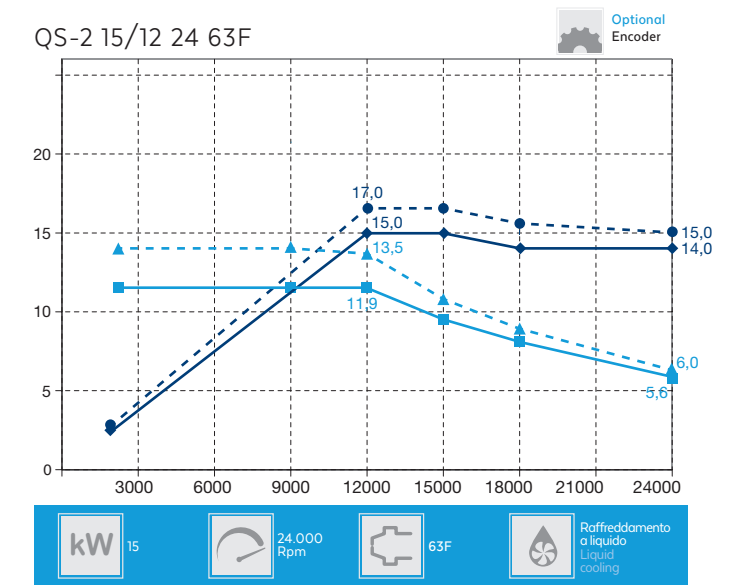
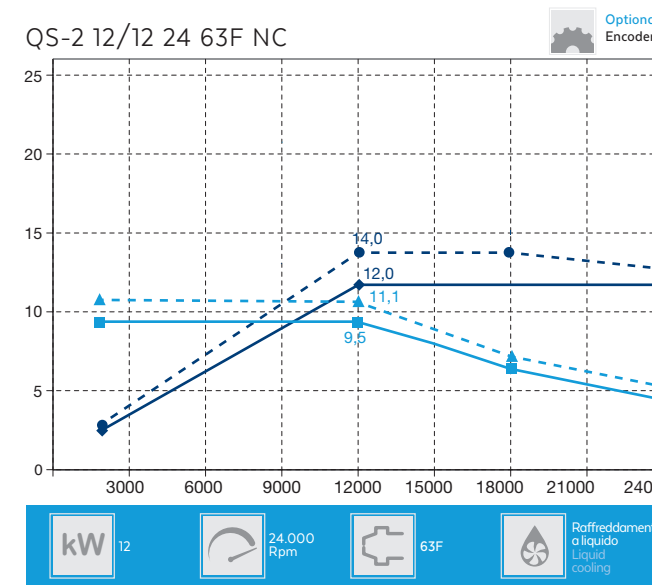

## SPECIFICHE TECNICHE TECHNICAL SPECIFICATIONS

	Asse B	Asse C
Servomotore <i>Servomotor</i>	Yaskawa*	Yaskawa*
Potenza servomotore <i>Servomotor power</i>	0,4 kW	0,4 kW
Encoder servomotore <i>Servomotor encoder</i>	Assoluto <i>Absolute 20 Bit</i>	Assoluto <i>Absolute 20 Bit</i>
Riduttore <i>Gearbox</i>	Harmonic Drive	Harmonic Drive
Coppia max continua <i>Max. continuous torque</i>	320 Nm	320 Nm
Coppia di picco <i>Peak torque</i>	570 Nm	570 Nm
Max rotazione asse <i>Max rotation axis</i>	±185°	±320°
Freni meccanici <i>Mechanical blocking axi</i>	No	Si <i>Yes</i>
Velocità posizionamento max <i>Max. positioning speed</i>	7.000°/'	7.000°/'
Velocità di lavoro max <i>Max operating speed</i>	4.000°/'	4.000°/'
Precisione di posizionamento assi <i>Precision positioning</i>	1 arcmin	1 arcmin
Peso <i>Weight</i>		100 kg

\*Sono disponibili altre marche di motorizzazioni a richiesta  
\*Other engines brands are available on demand