

SERIE ORBITAL ORBITAL J

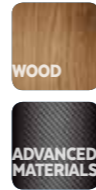

SPECIFICHE TECNICHE / TECHNICAL SPECIFICATIONS

*Sono disponibili altre marche di motorizzazioni a richiesta
*Other engine brands are available on demand

	ASSE B / B AXIS	ASSE C / C AXIS
Servomotore / Servomotor	Yaskawa*	Yaskawa*
Potenza servomotore / Servomotor power	0,4 kW	0,4 kW
Encoder servomotore / Servomotor encoder	Assoluto Absolute 20 Bit	Assoluto Absolute 20 Bit
Riduttore / Gearbox	Harmonic Drive	Harmonic Drive
Coppia max continua / Max. continuous torque	320 Nm	320 Nm
Coppia di picco / Peak torque	570 Nm	570 Nm
Max rotazione asse / Max axis rotation	±185°	±320°
Freni meccanici / Mechanical blocking of axes	No	No
Velocità posizionamento max / Max. positioning speed	7.000°/'	7.000°/'
Velocità di lavoro max / Max operating speed	4.000°/'	4.000°/'
Precisione di posizionamento assi / Axis positioning accuracy	1 arcmin	1 arcmin
Peso / Weight		55 kg

LAYOUT

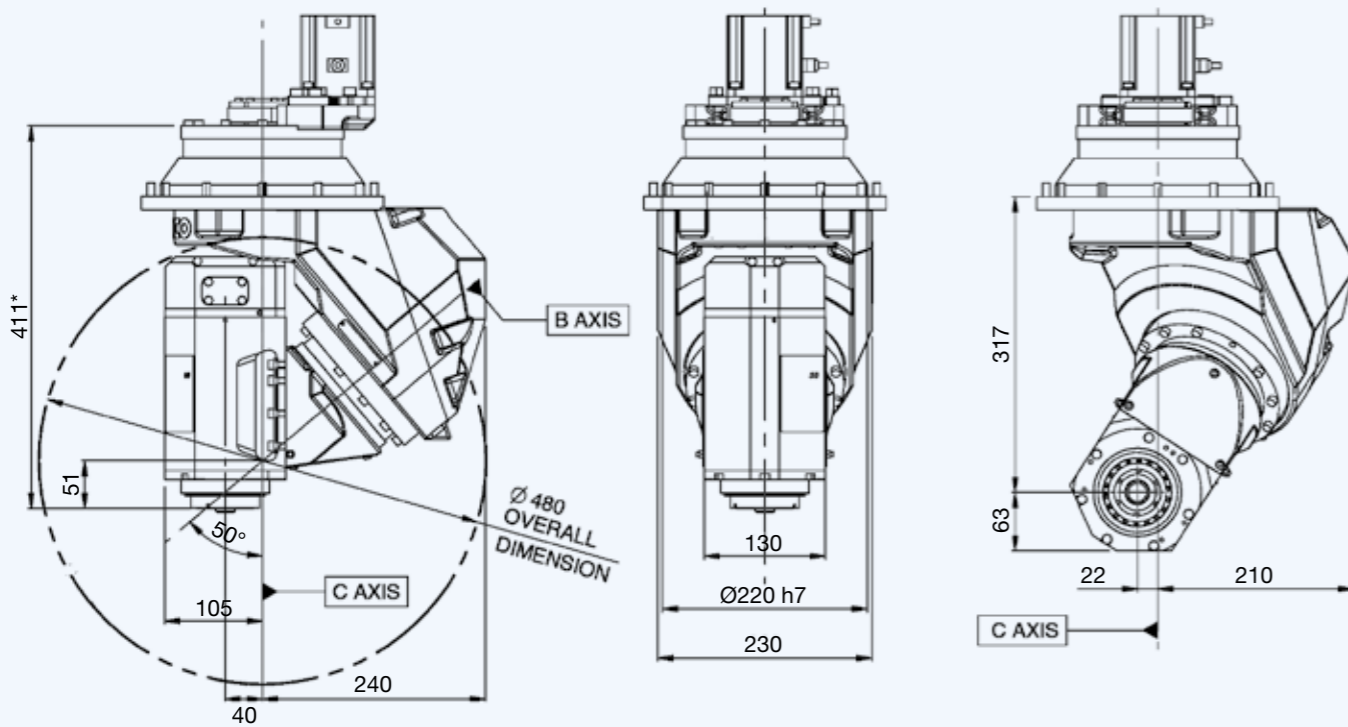

OPTIONALS DELL'ELETTROMANDRINO / ELECTROSPINDLE OPTIONS

- Monitoraggio temperatura cuscinetti / Temperature monitoring of bearings
- Misuratore di velocità / Speed monitoring
- Sensori di vibrazione / Vibration sensor
- Encoder*

ELETTROMANDRINI DISPONIBILI / AVAILABLE ELECTROSPINDLES

