

Pos.	Codice	Descrizione	Q.tà
1	0000307516F	SPINA 6 X 20 H8 ISO 2338 CILINDRICA	2
2	0391370302H	CORPO PINZA PER CONO HSK63F	1
3	0391370304C	PERNO L=20.6MM D=6MM DEXT8 CUT	2
4	03L0149774H	PIASTRA SP.MIN10 SP.MAX18 CAMBIOOUT.UNIV.HSK63F	1

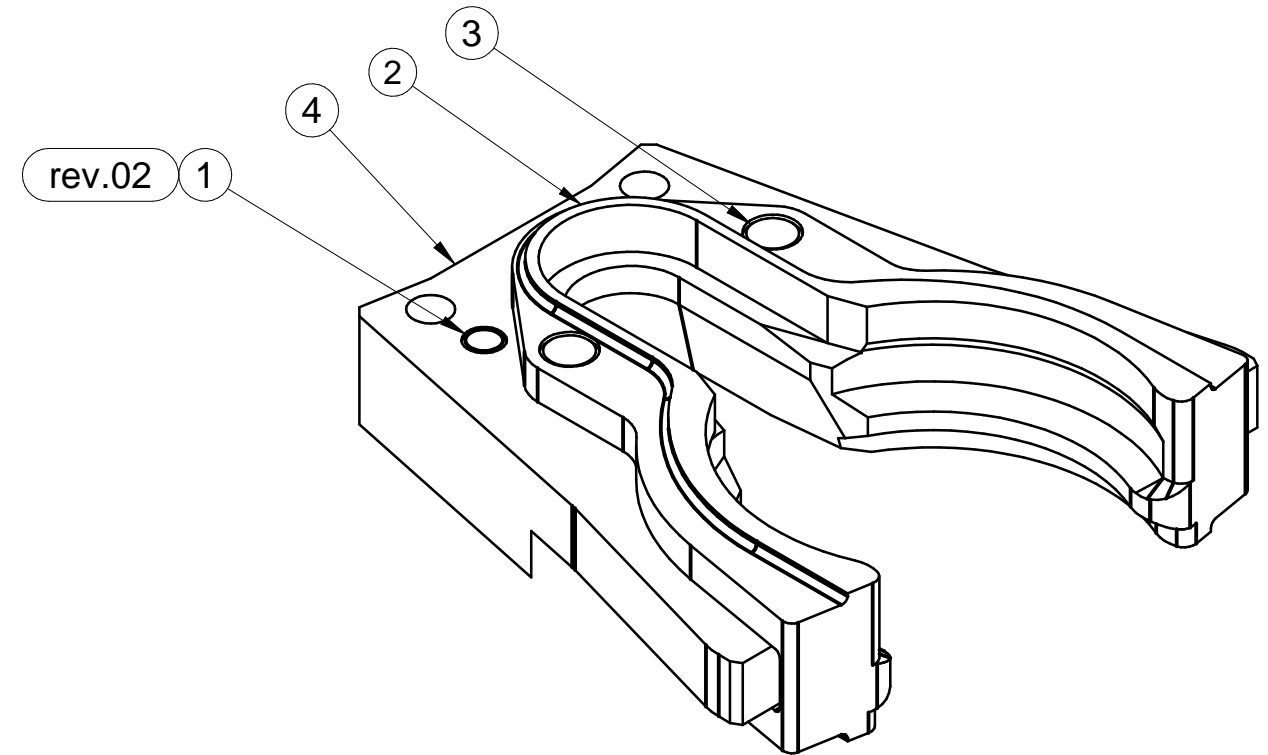
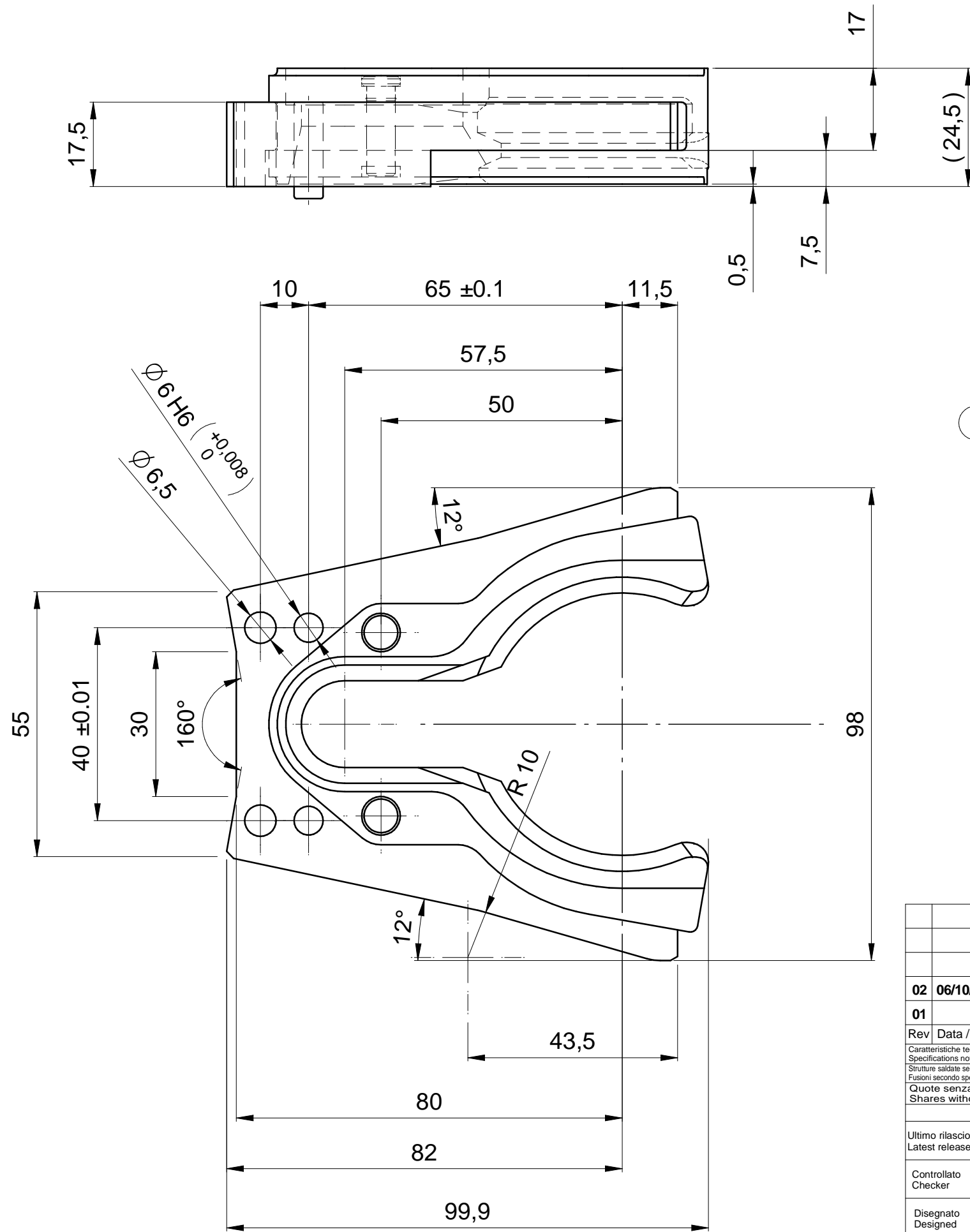

02	06/10/2016	L.GUIDUCCI	Aggiunto n°2 spine ø6x20 (0000307516F)	CN09601
01				
Rev	Data / Date	Firma / Signature	Descrizione ultima modifica / Last change description	N° Modifica / Change ID
<small>Caratteristiche tecniche non evidenziate secondo istruzione operativa SCM GROUP : IO 23/1DTG Specifications not shown according to SCM GROUP operation instruction : IO 23/1DTG Strutture saldate secondo specifica SCM / Welded according to SCM specific : ST232DTG Fusioni secondo specifica SCM / Mergers second SCM specific : ST233DTG</small>			Verniciatura / Painting (SCM specific ST231DTG)	Superficie / Surface (m²)
<small>Quote senza indicazione di tolleranza, grado di precisione Shares without indication of tolerance, accuracy</small>			SCM Specifica ST2310DTG	Trattamento Superficiale / Surface Treatment (SCM specific ST234DTG)
Ultimo rilascio Latest release			Rugosità / Roughness'	Trattamento Termico / Heat Treatment (SCM specific ST234DTG)
Controllato Checker			CF3 0 0	Peso grezzo/Raw weight (kg)
Disegnato Designed	C.Paesini	23/05/2013	Smussi / chamfer	Massa / Mass (kg)
			0,153	Materiale / Material (SCM specific ST235DTG)
				Vedi Tabella
			Denominazione / Item Name	
			ASS. PINZA CAMBIO UTENSILE UNIVERSALE HSK63F	
<small>Template version : 14</small>			Scala / Scale	Codice / Item ID
			1:1	29L0149776H
			Rev	Status
			02	
			Tav. N. di N.	
			1/1	