

Unità Aggregata / Aggregate Unit : **Master Line COPY ER32 H175** Codice / Code : **ML.COPY.01/175C63F-HO**

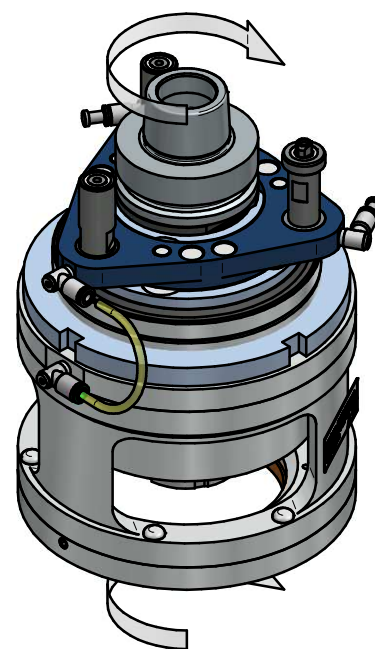
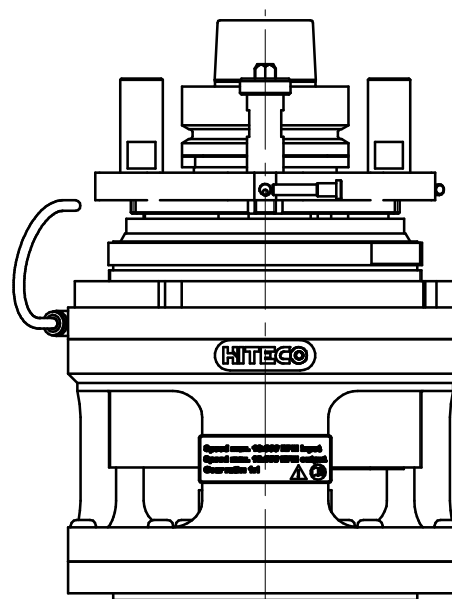
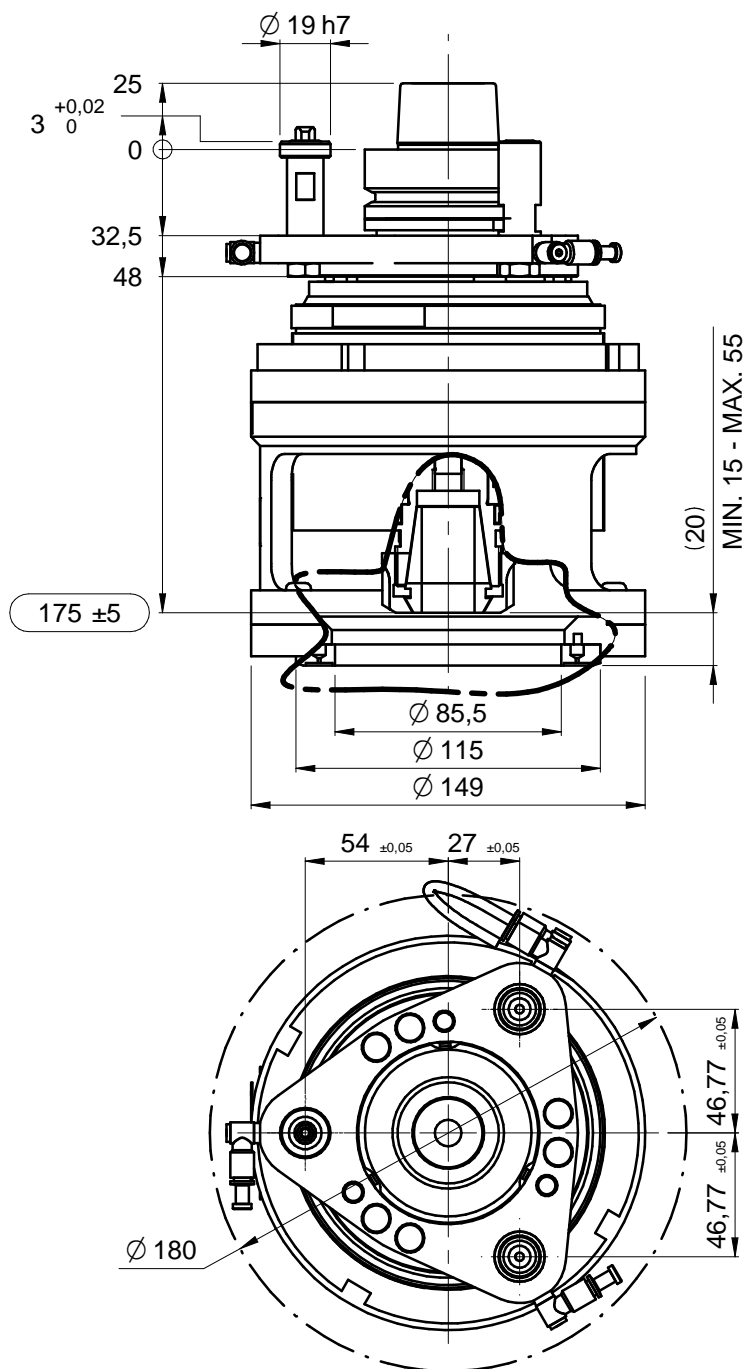

Specifiche tecniche / Technical specifications

Attacco mandrino - Spindle coupling	HSK 63F
Velocità Rotazione Max. - Max. Speed	18000 rpm max *
Senso rotazione mandrino - Spindle rotation direction	VEDI DISEGNO - See drawing
Possibilità inversione rotazione mandrino - Possibility to change electrospindle direction	NO
Rapporto di trasmissione - Gear ratio	1:1
Attacco utensile - Tool coupling	ER32
Diametro codolo - Tool shank diameter	$\varnothing 2 - \varnothing 20$
Capacità Palpante - Floating Capacity	10 mm
Distanza di Spostamento - Adjustment Capacity	40mm
Peso - Weight	~ 7,5 kg
Lubrificazione - Lubrication	GRASSO - grease
Temperatura - Temperature	75 °C max
Connessione asse C - C axis connection type	HOMAG
* vedere manuale - see user manual	