

Unità Aggregata / Aggregate Unit : **Master Line NOTCHING FRESA H180**
 Codice / Code : **ML.NOTCH.00/180P63F-H1**

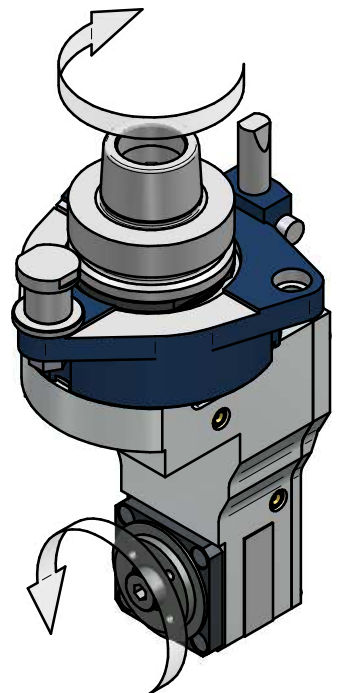
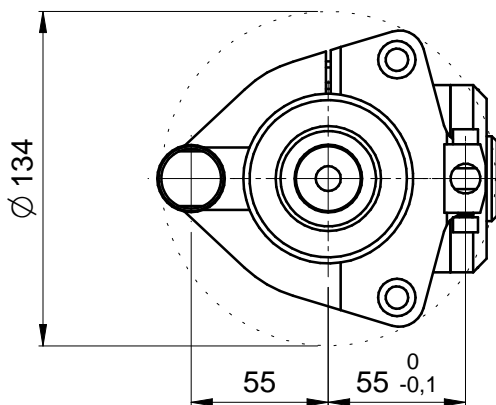
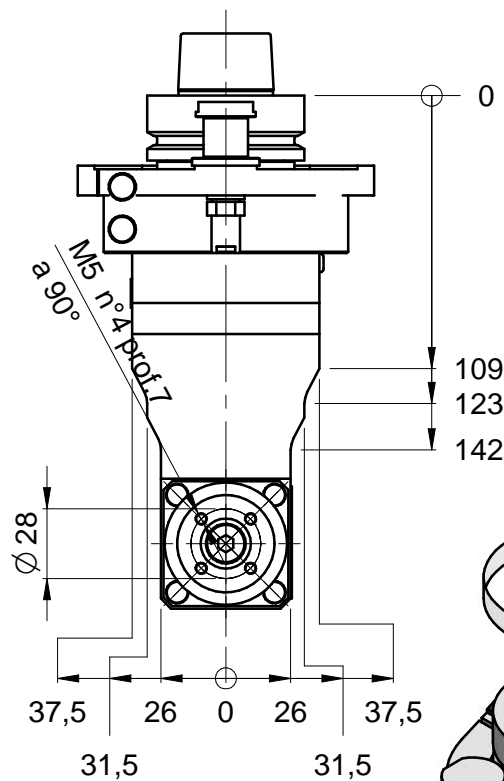
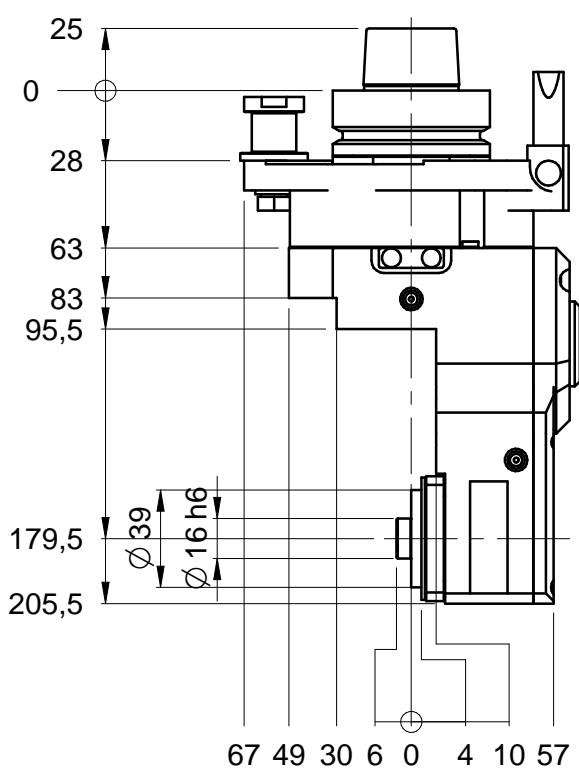

Specifiche tecniche / Technical specifications

Attacco elettromandrino - Spindle coupling	HSK63F
Velocità rotazione elettromandrino - Spindle speed	6000 RPM MAX.*
Velocità rotazione utensile - Tool speed	13000 RPM MAX.*
Senso rotazione mandrino - Spindle rotation direction	VEDI DISEGNO - See drawing
Possibilità inversione rotazione mandrino - Possibility to change electrospindle direction	SI
Rapporto di trasmissione - Gear ratio	1:2.17
Tipo pinza - Collet type	-
Diametro lama - Blade diameter	Ø70*
Diametro foro lama - Blade hole diameter	Ø16
Peso - Weight	5 Kg
Lubrificazione - Lubrication	Grease KLUEBER NBU15
Temperatura di lavoro - Working temperature	75°C / 167°F MAX
Connessione asse C /C axis connection type	HIT1
Orientamento angolare/ Aggregate rotation	0-360° in continuo/continuous
* VEDERE MANUALE/see user manual	