

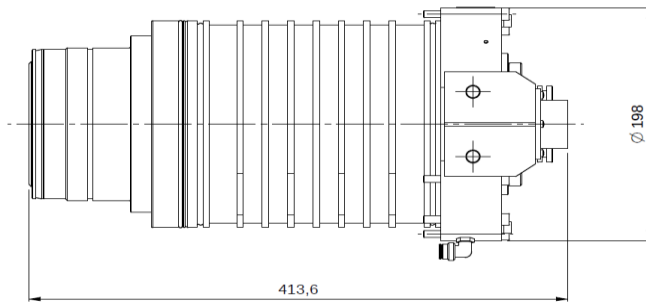

**Electrospindle ATC 30Kw 12.000 rpm  
MG-2 30/7.5 12 ISO 40 NL**

**MG.000.L01**

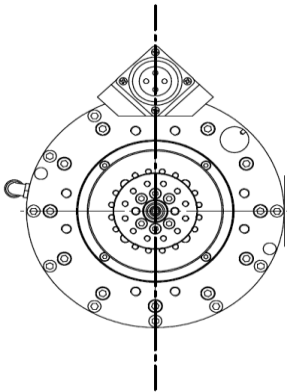

**Prestazioni - Performances**

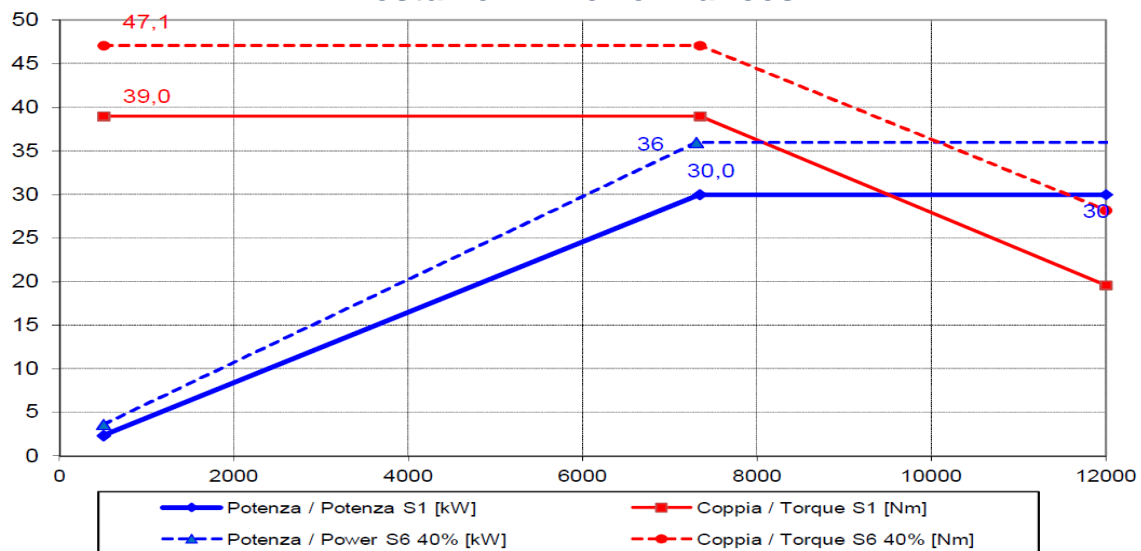

**Specifiche tecniche/ Technical Specifications**

<b>Tipologia elettromandrino / Electrospindle type</b>	Asincrono-4 poli / Synchronous-4poles
<b>Attacco utensile / Tool interface</b>	ISO 40
<b>Velocità rotazione max / Max speed</b>	12000 rpm
<b>Raffreddamento / cooling</b>	Liquido / Liquid
<b>Cuscinetti / Ball bearings</b>	Ceramici / Ceramic
<b>Lubrificazione cuscinetti / Bearings lubrication</b>	Grasso a vita / Grease long life
<b>Connessione pneumatiche / Pneumatic connection</b>	Sblocco uten. / Release. tool: G3/8 80-85 bar Pressurizzazione / Air seal. E4 6-6,5 bar
<b>Potenza max. (S1 - S6) / Max. Power.(S1 - S6)</b>	Soffio cono-aria utensile / Taper cleaning-air tool E4 6-6,5 bar 30 kW @7500 Rpm (S1) / 36 kW @ 7500 Rpm (S6)
<b>Coppia max. (S1 - S6) / Max. Torque (S1 - S6)</b>	39 Nm (S1) / 47,1 Nm (S6)
<b>Corrente (S1 - S6) / Current (S1 - S6)</b>	66 A (S1) / 78 A (S6)
<b>Tensione / Voltage</b>	400 V
<b>Rotazione / Rotation</b>	CW – CCW
<b>Azionamento / Supply</b>	Con inverter / By inverter
<b>Sensoristica / Sensors</b>	S1 Afferraggio utensile / S1 Tool lock S2 Pinza aperta / S2 Open clamp
<b>Peso / Weight</b>	73 kg