

PUNZONARE SU CARCASSA
EI XXXX YY/ZZ
XX=SERIALE
YY=MESE DI PROD.
ZZ=ANNO DI PROD.

TARGHETTA IDENTIFICATIVA
03L0286106H

ATTACCO ISO 30 DIN 69871-1
TOOL INTERFACE ISO30 DIN 69871-1

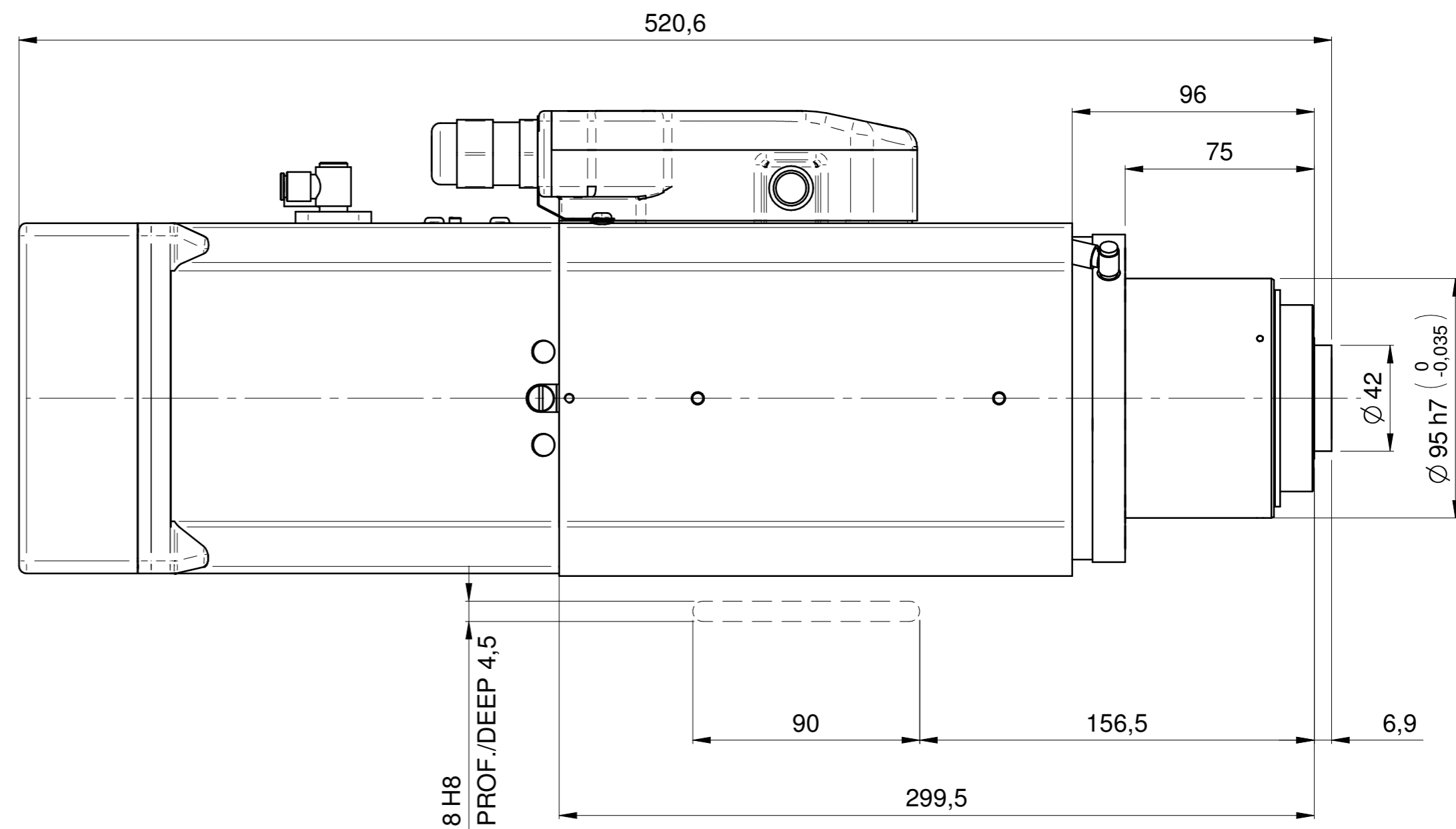

SOFFIO CONO: E6 ARIA SECCA 6-6,5 bar
TAPER CLEANING: E6 AIR DRY 6-6,5 bar

PRESSACAVO MET.M16 DIR. X EMC
METALLIC GLAND M16 STRAIGHT FOR EMC

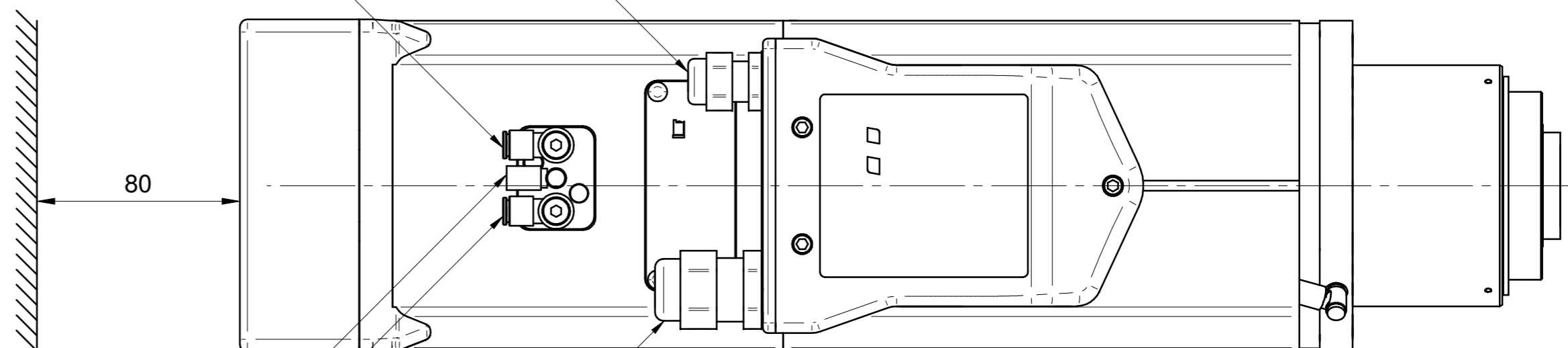

UTENSILE: E4 ARIA SECCA 6-6,5 bar
OL: E4 AIR DRY 6-6,5 bar
UTENSILE: E6 ARIA SECCA 6-6,5 bar
TOOL: E6 AIR DRY 6-6,5 bar

PRESSACAVO MET.M25 DIR. X EMC
METALLIC GLAND M25 STRAIGHT FOR EMC

Massa: 24 Kg

Rev	Data / Date	Firma / Signature	Descrizione ultima modifica / Last change description	N° Modifica / Change ID
Caratteristiche tecniche non evidenziate secondo istruzione operativa SCM GROUP : IO 2310DTG Specifications not shown according to SCM GROUP operation instruction : IO 2310DTG Struttura salibile secondo specifica SCM / Welded according to SCM specific : ST2320DTG Finiture secondo specifica SCM / Finishes secondo SCM specific : ST2320DTG Quote senza indicazione di tolleranza, grado di precisione Shares without indication of tolerance, accuracy.			Verniciatura / Painting (SCM specific ST231DTG) VER000 Superficie / Surface (m²)	
Ultimo rilascio Latest release			Trattamento Superficiale / Surface Treatment (SCM specific ST234DTG)	
Controllato Checker			Trattamento Termico / Heat Treatment (SCM specific ST234DTG)	
Disegnato Designed G.Franchino			Data / Date 16/05/2016	
Rugosità / Roughness CF1			Peso grezzo/Raw weight (kg) 30	
Smussi / chamfer			Massa / Mass (kg) 24	
Denominazione / Item Name ELETEM QE-1F 5.5/6 20 I30 NC CB DV			Codice / Item ID 29L0286119B	
HITECO HIGH TECHNOLOGY COMPONENTS			Rev 01 Status	
Template version: 12			Tav. N. di N. 3/3	