

**DETTAGLIO Z
1:1**

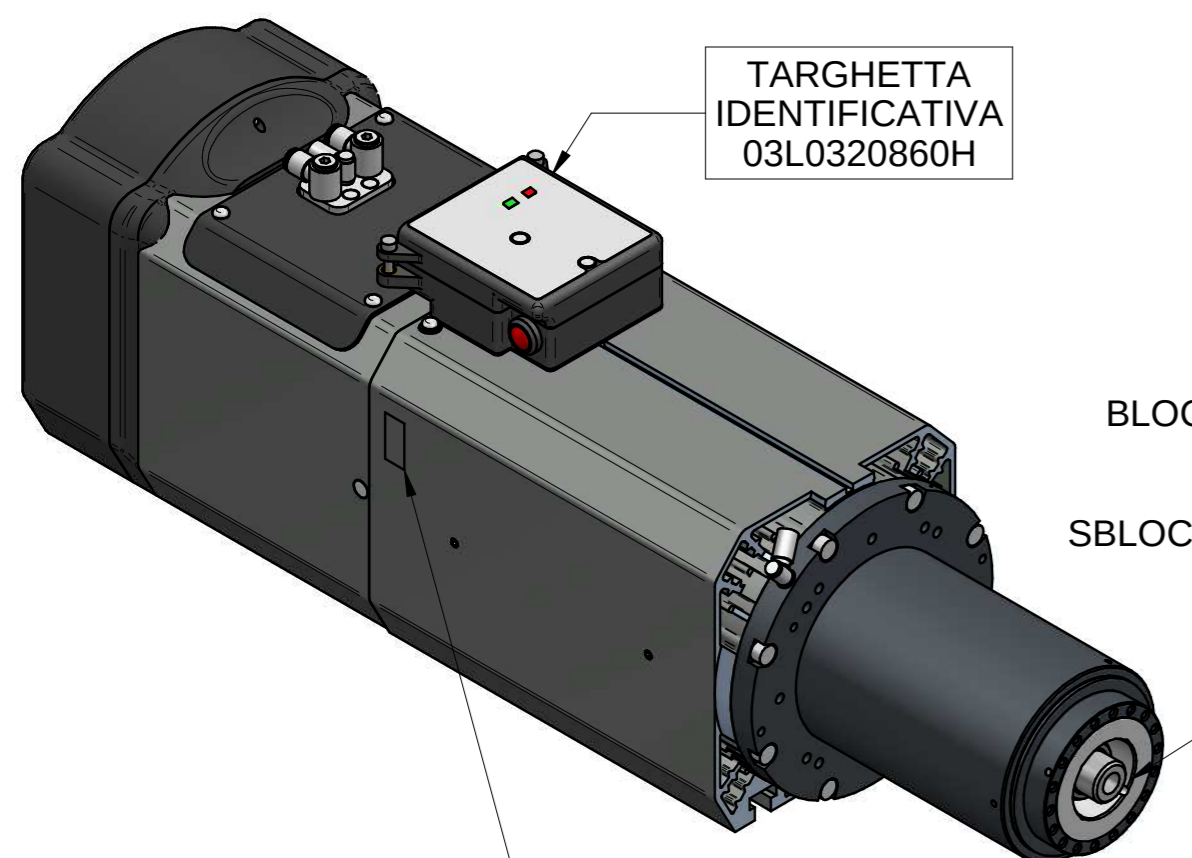

TARGHETTA IDENTIFICATIVA
03L0320860H

PUNZONARE SU CARCASSA
STAMP ON HOUSING

EK XXXX YY/ZZ

XXXX = NUMERO SERIALE - SERIAL NUMBER
YY = MESE DI PROD. - MONTH OF PROD.
ZZ = ANNO DI PROD. - YEAR OF PROD.

SOFFIO CONO: E6 ARIA SECCA 6 BAR
TAPER CLEANING: E6 DRY AIR 6 BAR

BLOCCO UTENSILE: E4 ARIA SECCA 6 BAR
TOOL LOCK TOOL: E4 DRY AIR 6 BAR

SBLOCCO UTENSILE: E6 ARIA SECCA 6 BAR
TOOL RELEASE: E6 DRY AIR 6 BAR

**ATTACCO HSK 63E
TOOL INTERFACE HSK 63E**

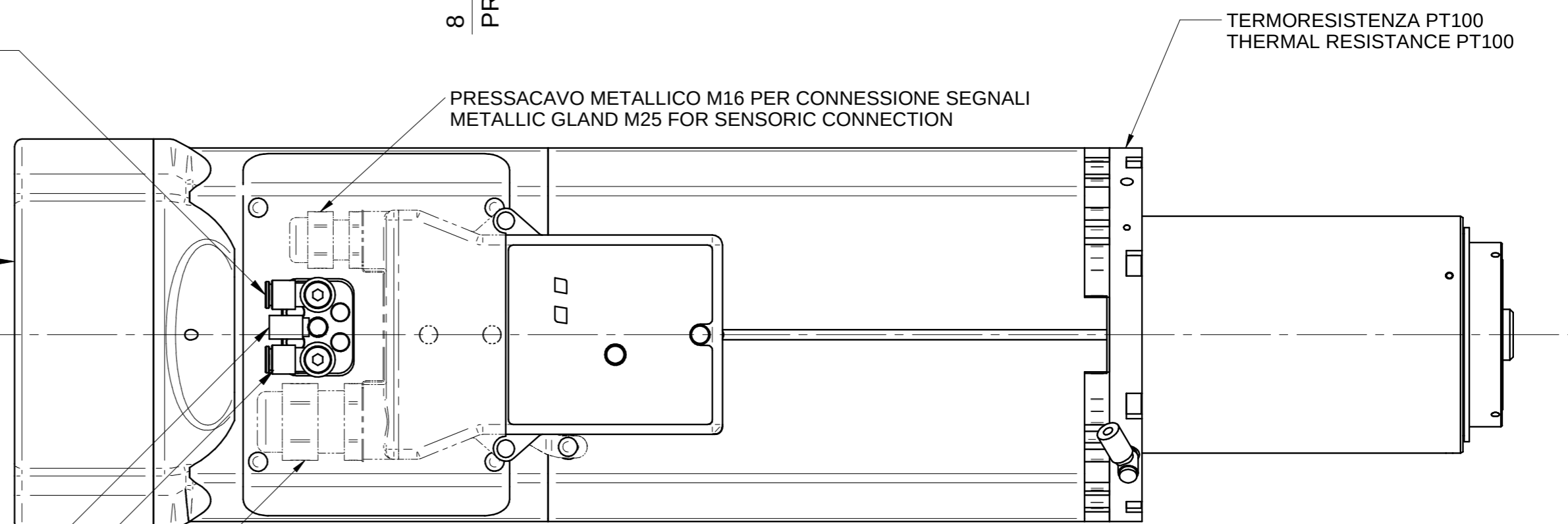
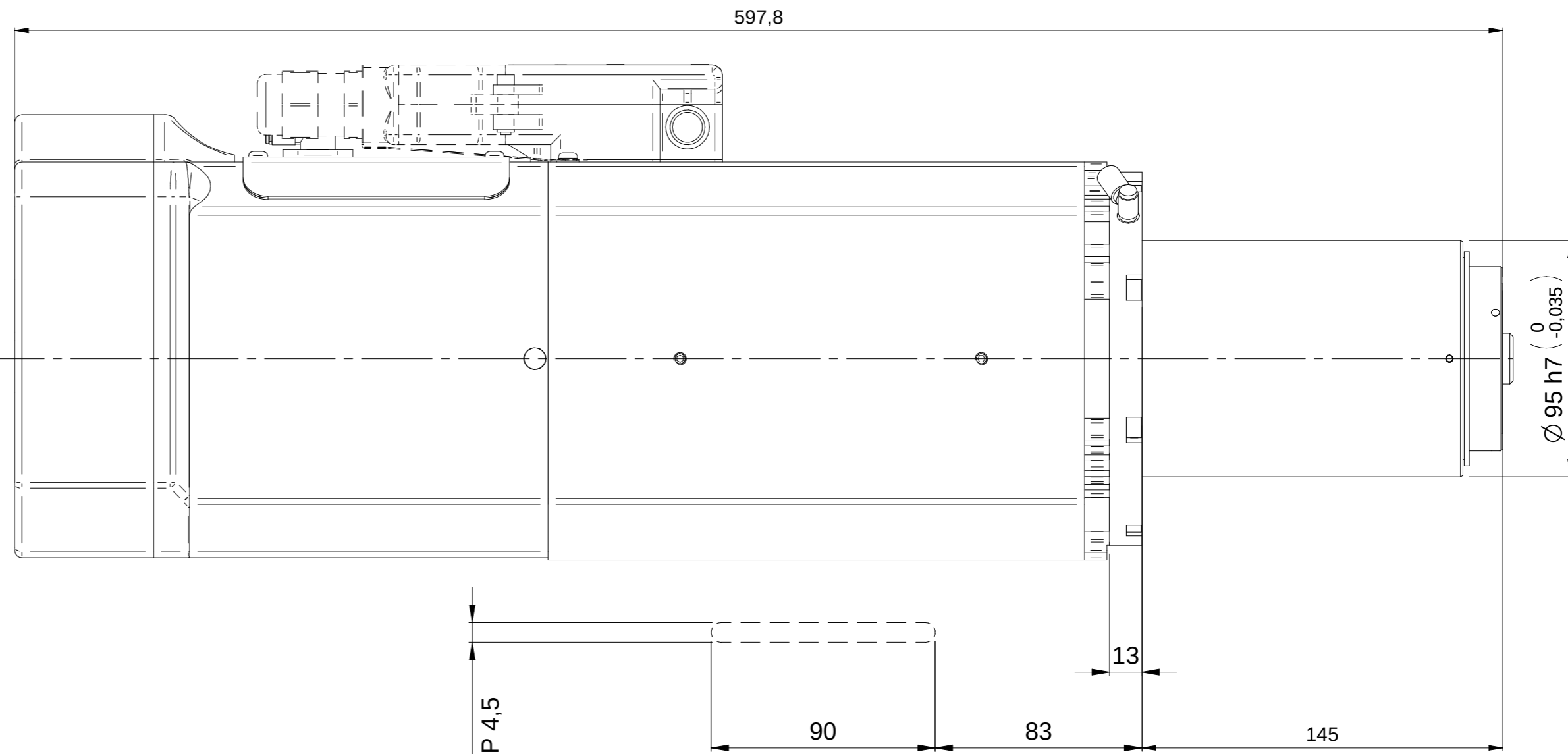

PRESSACAVO METALLICO M25 PER CONNESSIONE POTENZA
METALLIC GLAND M25 FOR POWER CONNECTION

MASSA MASS: 32Kg

00							
Rev	Data / Date	Firma / Signature	Descrizione ultima modifica / Last change description			N° Modifica / Change ID	
Caratteristiche tecniche non evidenziate secondo istruzioni operative SCM GROUP : IO 231D1TG		Specificazioni non mostrate secondo istruzioni operative SCM GROUP : IO 231D1TG		Verniciatura / Painting (SCM specific ST231D1TG)		Superficie / Surface (m²)	
Strutture saldate secondo specifica SCM / Welded according to SCM specific : ST23201G		Finiture secondo specifica SCM / Finishes second SCM specific : ST23201G		VER000			
Quote senza indicazione di tolleranza, grado di precisione		Shares without indication of tolerance, accuracy		mK - UNI EN 22768/1-2		Trattamento Superficiale / Surface Treatment (SCM specific ST234D1TG)	
Ultimo rilascio / Latest release		Firma / Signature	Data / Date	Rugosità / Roughness		Trattamento Termico / Heat Treatment (SCM specific ST234D1TG)	
Controllato / Checked				CF1 4 1		Ricavare da o Stato di fornitura / Based on or State of supply	
Disegnato / Designed		G.Franchino	12/05/2016	Smussi / chamfer		Materiale / Material (SCM specific ST235D1TG)	
				Massa / Mass (kg) 43,455		Vedi Tabella	
				Denominazione / Item Name			
				ELETM QF-1F 8/9 18 63E NL PP			
				Scala / Scale		Codice / Item ID	
				1:1		Rev 00 Status Tav. N. di N. 3/3	

