

Elettromandrino / electrospindle
PX-2 20/10 24 63E NC
Codice / Code:
29L0415566E

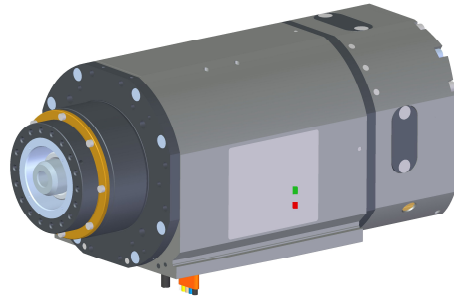

Prestazioni - Performances

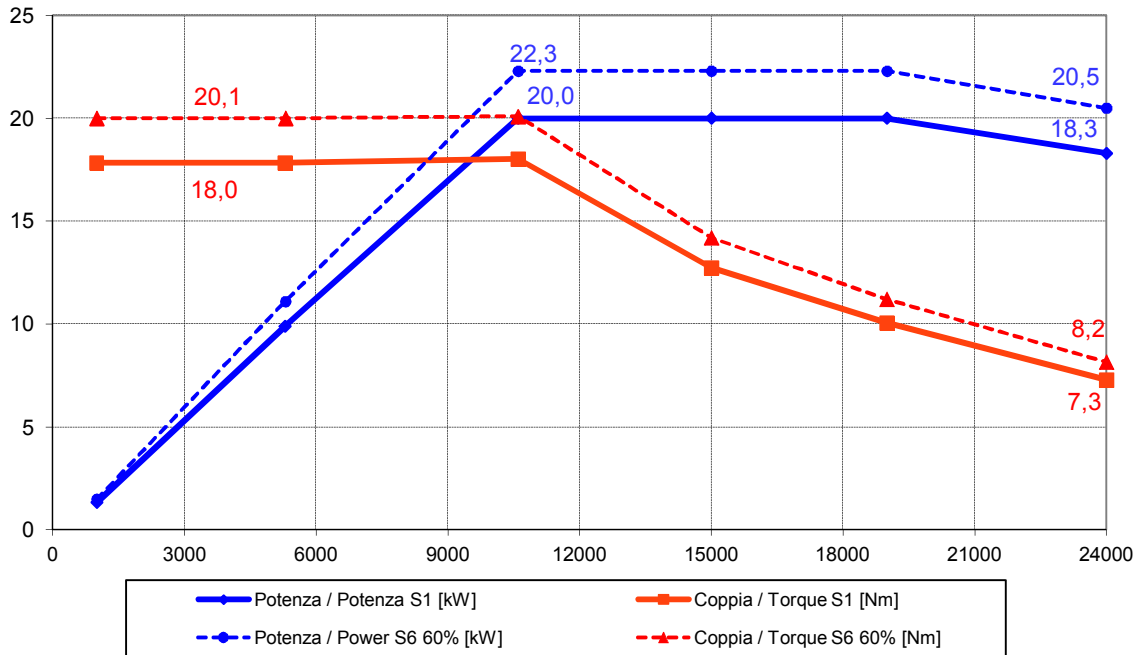

Specifiche tecniche / Technical specifications	
Potenza max. (serv. S1) / Max. Power.(S1 duty)	20 kW @ 10600 Rpm
Coppia max. (serv. S1) / Max. Torque (S1 duty)	17.8 Nm
Corrente (serv. S1) / Current (S1 duty)	48 A
Potenza max. (serv. S6 60%) / Max. Power.(S6 60% duty)	22.3 kW @ 10600 Rpm
Coppia max. (serv. S6 60%) / Max. Torque (S6 60% duty)	20.1 Nm
Corrente (serv. S6 60%) / Current (S6 60% duty)	50 A
Tensione / Voltage	380 V
Numero poli / Poles	4
Velocità rotazione max / Max Speed	24 000 Rpm
Rotazione / Rotation	CW - CCW
Azionamento / Supply	con inverter / by inverter
Attacco utensile / Tool interface	HSK 63E
Cuscinetti / Ball bearings	Ceramici obliqui ad alta velocità alta precisione / Ceramic high speed high precision angular contact ball bearings Ant./Front: coppia / pair Post./Rear: coppia / pair
Raffreddamento / cooling	a liquido mediante scambiatore di calore/ liquid by heat exchanger
Sensoristica / Sensors	S1 Afferraggio utensile / Tool lock
	S2 Pinza aperta / Open clamp
	S3 Rotazione albero / Spindle rotation
Conessioni pneumatiche / Air inlets	Sblocco/Release tool: E6 9,5÷10,5 bar
	Press./Pressurization.: E6 4÷4,5 bar
	Soffio/Taper clean.: E6 4÷4,5 bar
Peso / Weight	25 kg