

LAYOUT

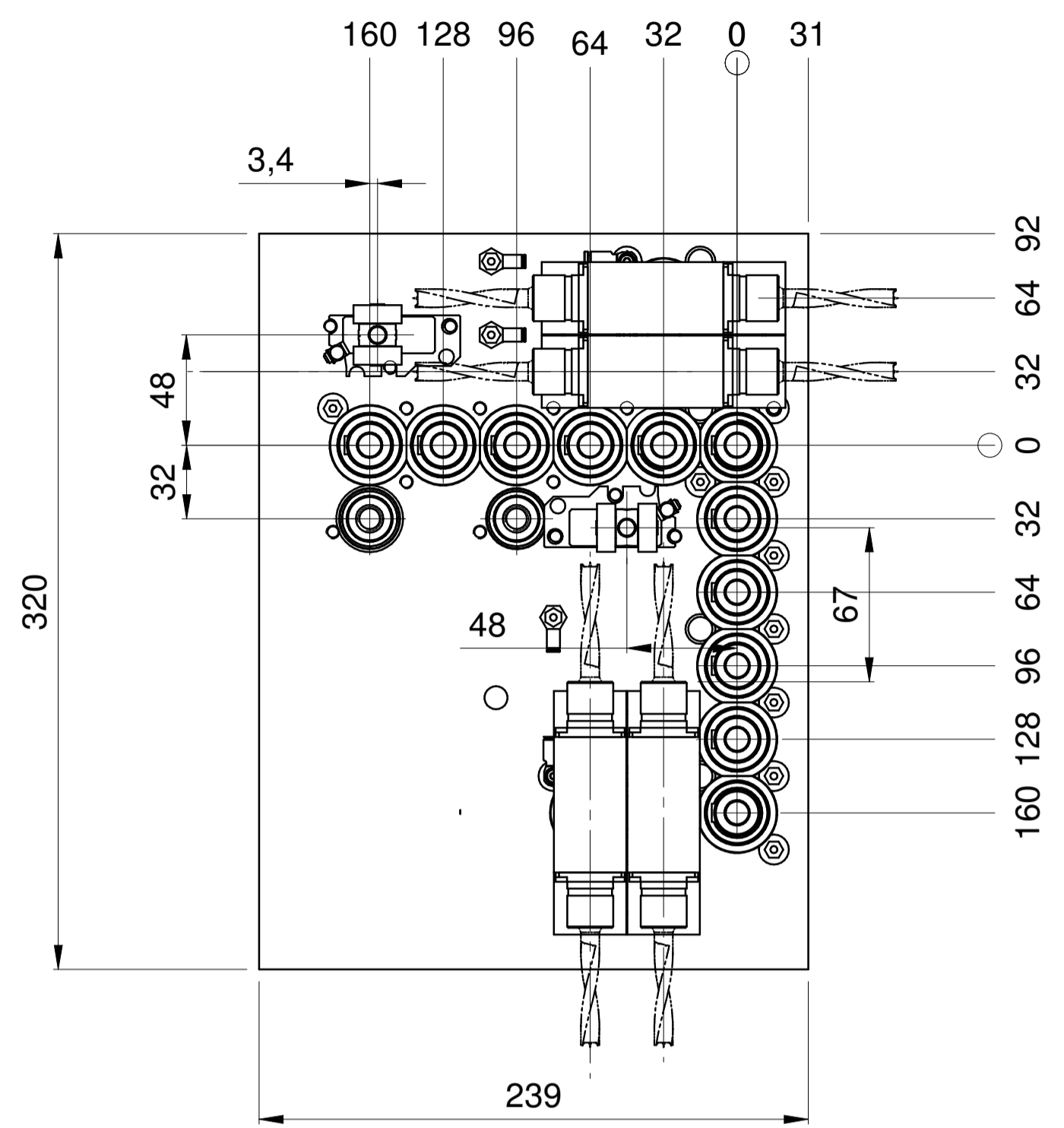

MOTOR ROTATION CW (RH)  
(direction of rotation of motor and spindles  
seen from above, motor side)

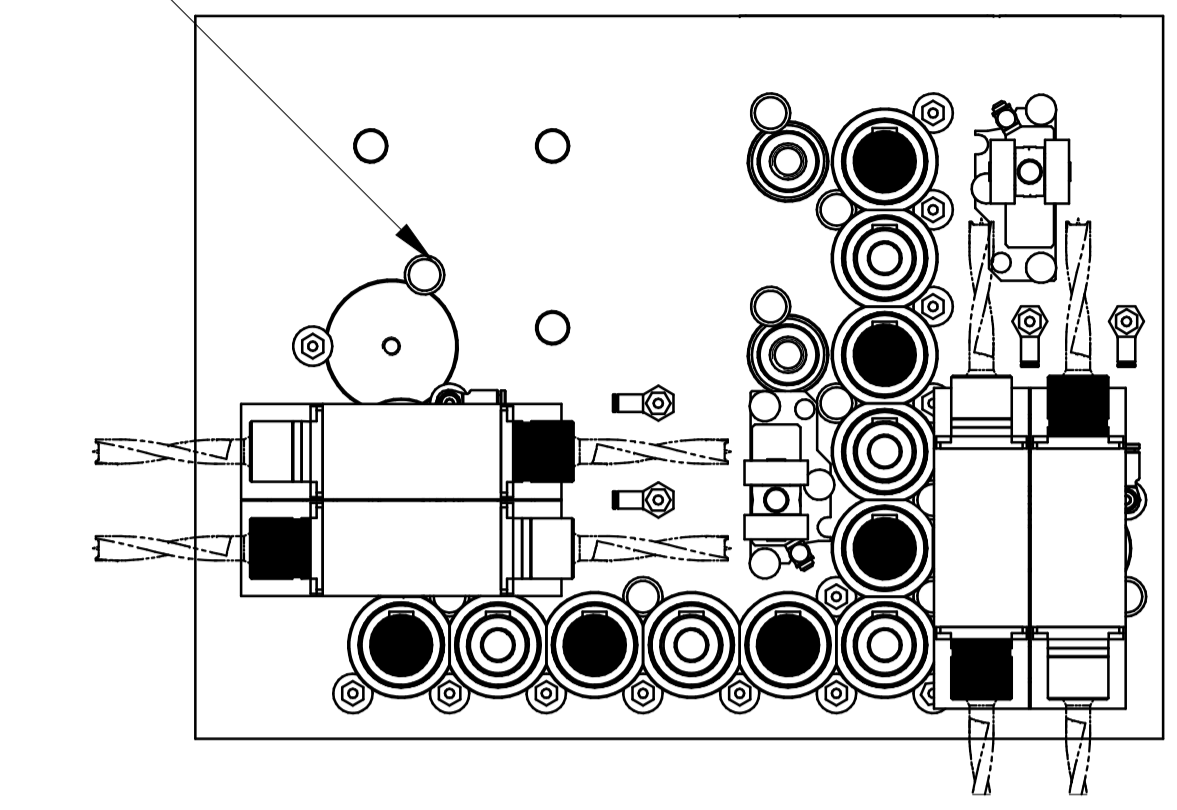

- ROTAZIONE DESTRA / RIGHT ROTATION
- ROTAZIONE SINISTRA / LEFT ROTATION
- ROTAZIONE DESTRA / RIGHT ROTATION
- ROTAZIONE SINISTRA / LEFT ROTATION

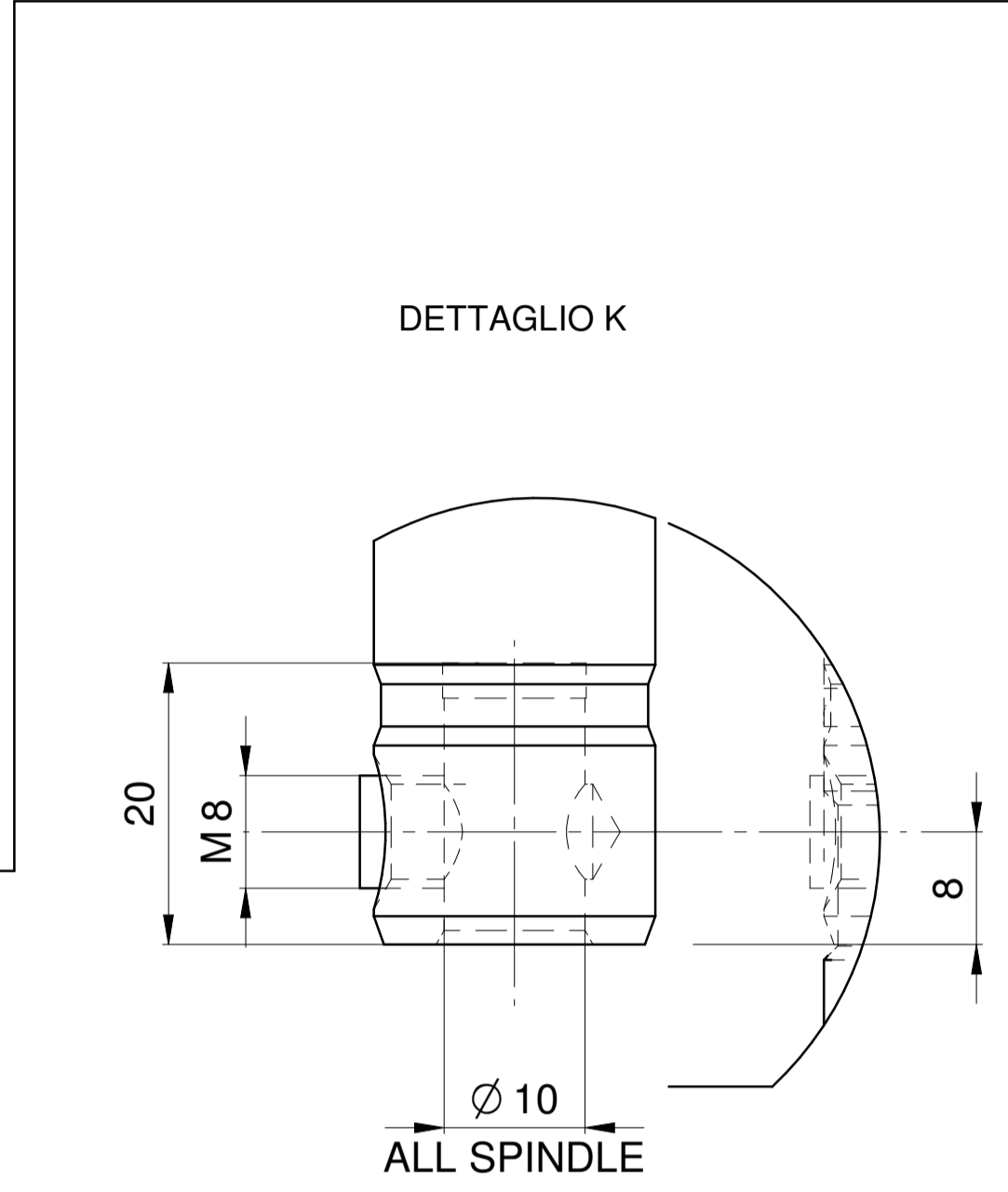

CARATTERISTICHE TECNICHE / TECHNICAL FEATURES	
MANDRINI VERTICALI / VERTICAL SPINDLES	11
MANDRINI ORIZZONTALI / HORIZONTAL SPINDLES	4
LAMA / BLADE SPINDLE	-
ATTACCO PUNTE / TOOL CONNECTION	10 H7 mm
INTERASSE PUNTE /DISTANCE BETWEEN CENTERS	32 mm
MAX LUNGHEZZA PUNTE / MAX BORING BITS LENGHT	70 mm (VERTICAL)
DIMENSIONE LAMA / BLADE DIMENSION	-
CENTRAGGIO LAMA / BLADE SHAFT	-
CORSA MANDRINI VERTICALI / VERTICAL SPINDLES STROKE	60 mm (SINGLE EFFECT CYLINDER)
CORSA MANDRINI ORIZZONTALI / HORIZONTAL SPINDLES STROKE	75 mm (DOUBLE EFFECT CYLINDERS)
CORSA GRUPPO LAMA / BLADE UNIT STROKE	-
SPINTA VERTICALE MANDRINI / VERTICAL SPINDLES THRUST	335 N ( 6 bar) - 550 N (9 bar)
POTENZA MOTORE / MOTOR POWER	1,7 kW
TENSIONE NOMINALE /RATED VOLTAGE	230 / 380 V
CORRENTE NOMINALE / RATED CURRENT	6,1 A / 3,5 A
VELOCITA' ROTAZIONE MOTORE / MOTOR RATED SPEED	2770 RPM (50 Hz)
SENSO DI ROTAZIONE MOTORE / MOTOR ROTATION	DESTRO / RIGHT
FREQUENZA NOMINALE / RATED FREQUENCY	50 Hz
COS f	0,72
ALIMENTAZIONE MOTORE / ELECTRICAL SUPPLY	50 Hz / 25-95 Hz
RAPPORTO DI TRASMISSIONE /SPEED RATIO (SPINDLES/MOTOR)	15
ROTAZIONE VERTICALI / VERTICAL SPINDLES SPEED	4000 RPM / 2000-8000 RPM
ROTAZIONE ORIZZONTALI / HORIZONTAL SPINDLES SPEED	4000 RPM / 2000-8000 RPM
RAPPORTO DI TRASMISSIONE /SPEED RATIO BLADE/MOTOR	-
ROTAZIONE LAMA / BLADE SPEED	-
LUBRIFICANTE / LUBRICATOR (VEDI MANUALE/SEE USER MANUAL)	GREASE KLUEBER ISOFLEX NBU15
PESO / WEIGHT	65 kg

