

LAYOUT

SENSO DI ROTAZIONE MOTORE ORARIO (DX)
(senso rotazione motore e mandrini visto da sopra, lato motore)

MOTOR ROTATION CW (RH)
(direction of rotation of motor and spindles seen from above, motor side)

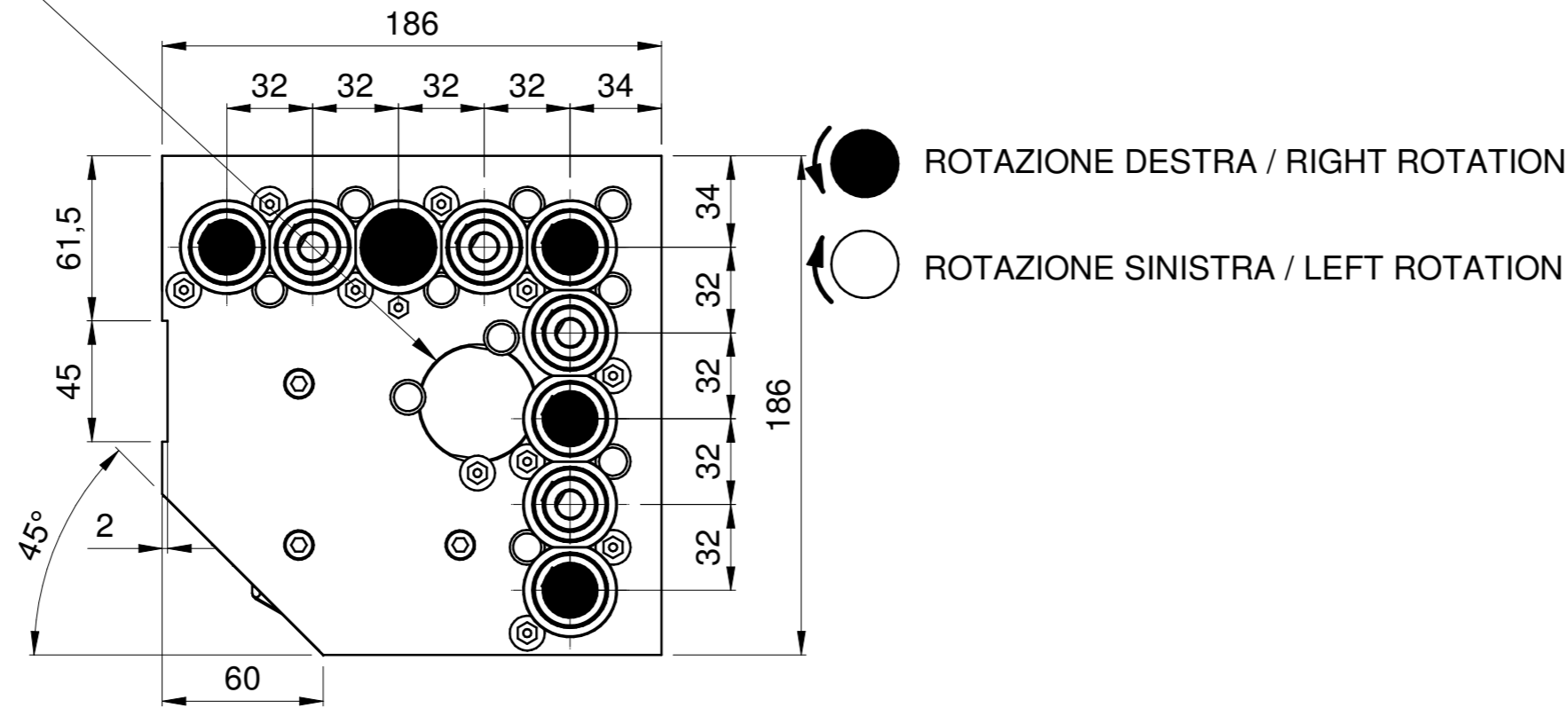
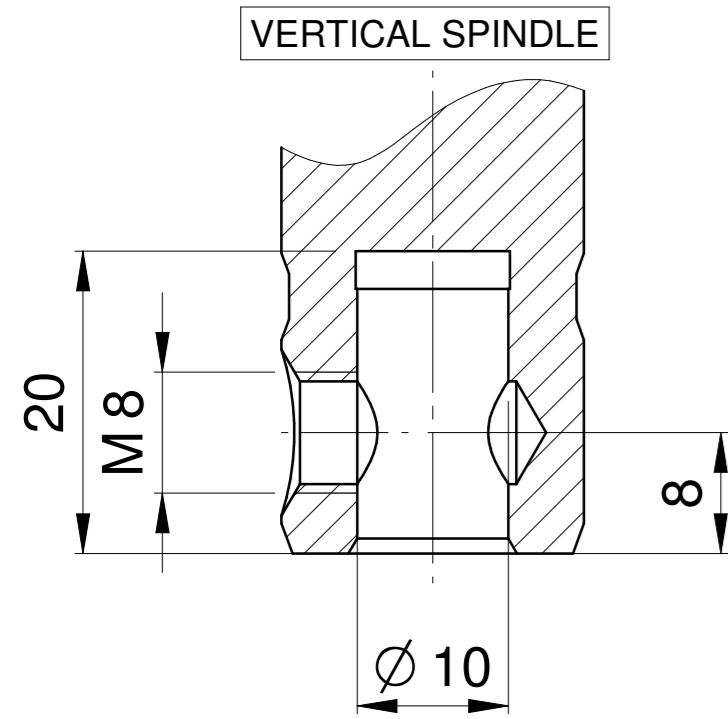

CARATTERISTICHE TECNICHE / TECHNICAL FEATURES

MANDRINI VERTICALI / VERTICAL SPINDLES	9
MANDRINI ORIZZONTALI / HORIZONTAL SPINDLES	-
LAMA / BLADE SPINDLE	-
ATTACCO PUNTE / TOOL CONNECTION	10 H7 mm
INTERASSE PUNTE / DISTANCE BETWEEN CENTERS	32 mm
MAX LUNGHEZZA PUNTE / MAX BORING BITS LENGTH	70 mm
DIMENSIONE LAMA / BLADE DIMENSION	-
CENTRAGGIO LAMA / BLADE SHAFT	-
CORSA MANDRINI VERTICALI / VERTICAL SPINDLES STROKE	75 mm (SINGLE EFFECT CYLINDER)
CORSA MANDRINI ORIZZONTALI / HORIZONTAL SPINDLES STROKE	-
CORSA GRUPPO LAMA / BLADE UNIT STROKE	-
SPINTA VERTICALE MANDRINI / VERTICAL SPINDLES THRUST	335 N (6 bar) - 550 N (9 bar)
POTENZA MOTORE / MOTOR POWER	15 kW
TENSIONE NOMINALE / RATED VOLTAGE	230 / 380 V
CORRENTE NOMINALE / RATED CURRENT	6.1 A / 3.5 A
VELOCITA' ROTAZIONE MOTORE / MOTOR RATED SPEED	2750 RPM (50 Hz)
SENSO DI ROTAZIONE MOTORE / MOTOR ROTATION	DESTRO / RIGHT
FREQUENZA NOMINALE / RATED FREQUENCY	50 Hz
COS φ	0.82
ALIMENTAZIONE MOTORE / ELECTRICAL SUPPLY	50 Hz / 25-95 Hz
RAPPORTO DI TRASMISSIONE / SPEED RATIO (SPINDLES/MOTOR)	15
ROTAZIONE VERTICALI / VERTICAL SPINDLES SPEED	4000 RPM / 2000-8000 RPM
ROTAZIONE ORIZZONTALI / HORIZONTAL SPINDLES SPEED	-
RAPPORTO DI TRASMISSIONE / SPEED RATIO BLADE/MOTOR	-
ROTAZIONE LAMA / BLADE SPEED	-
LUBRIFICANTE / LUBRICATOR (VEDI MANUALE/SEE USER MANUAL)	GREASE KLUEBER ISOFLEX NBU15
PESO / WEIGHT	29 kg

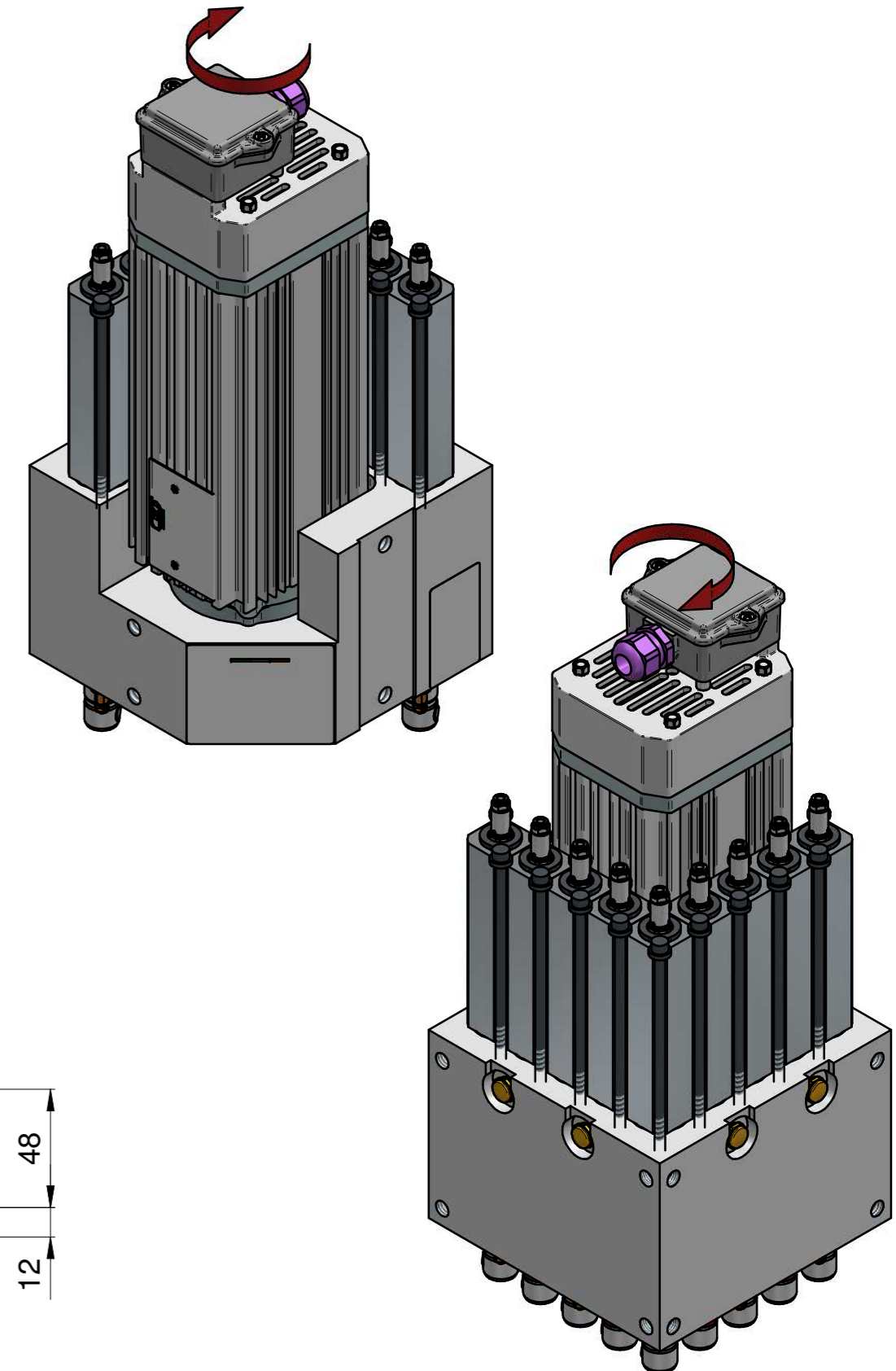
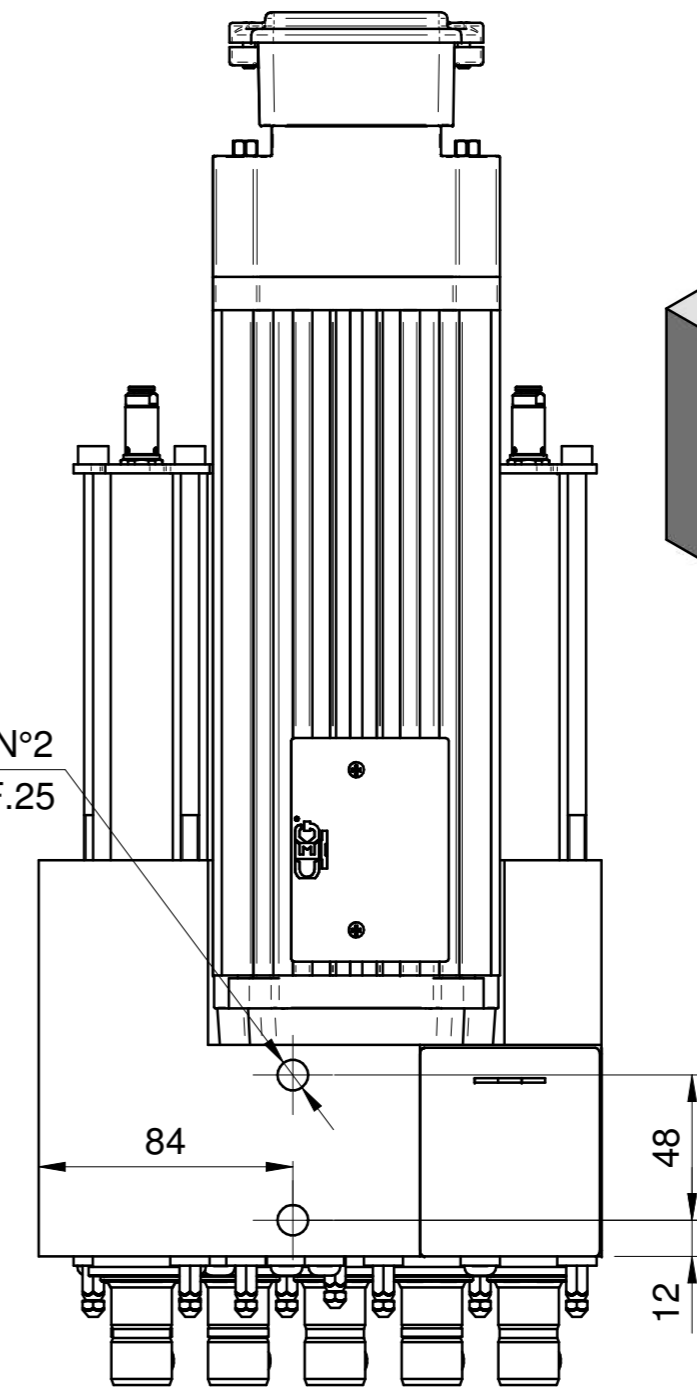
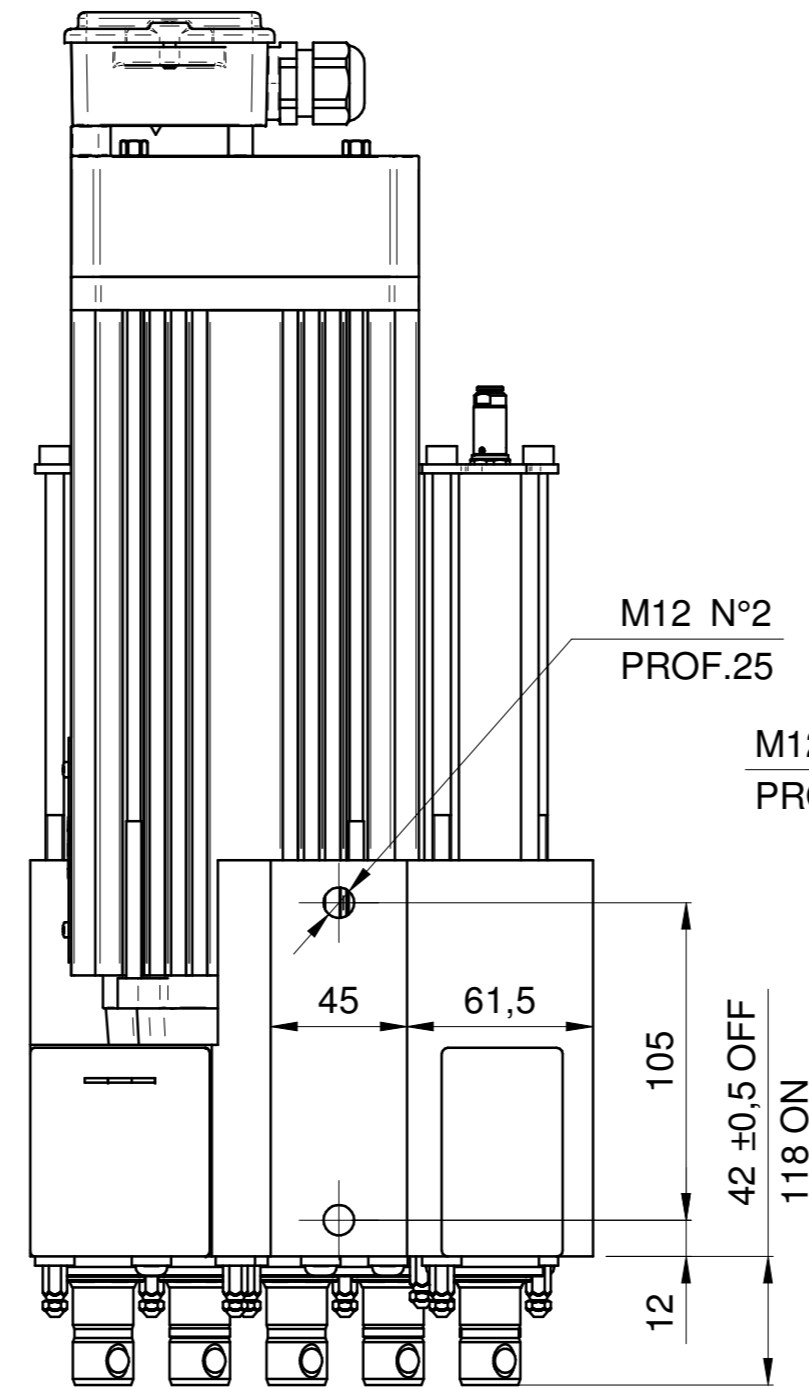
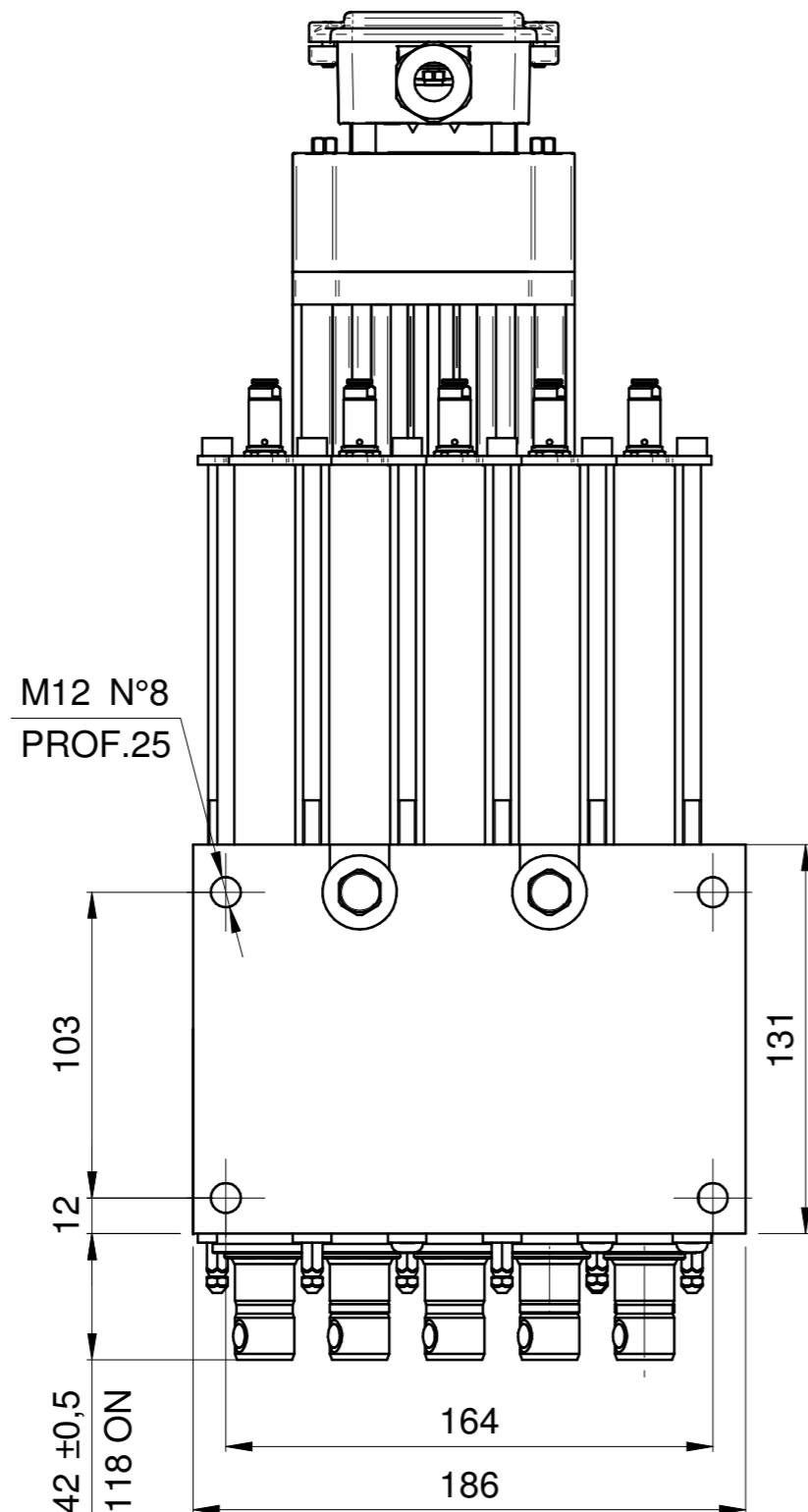
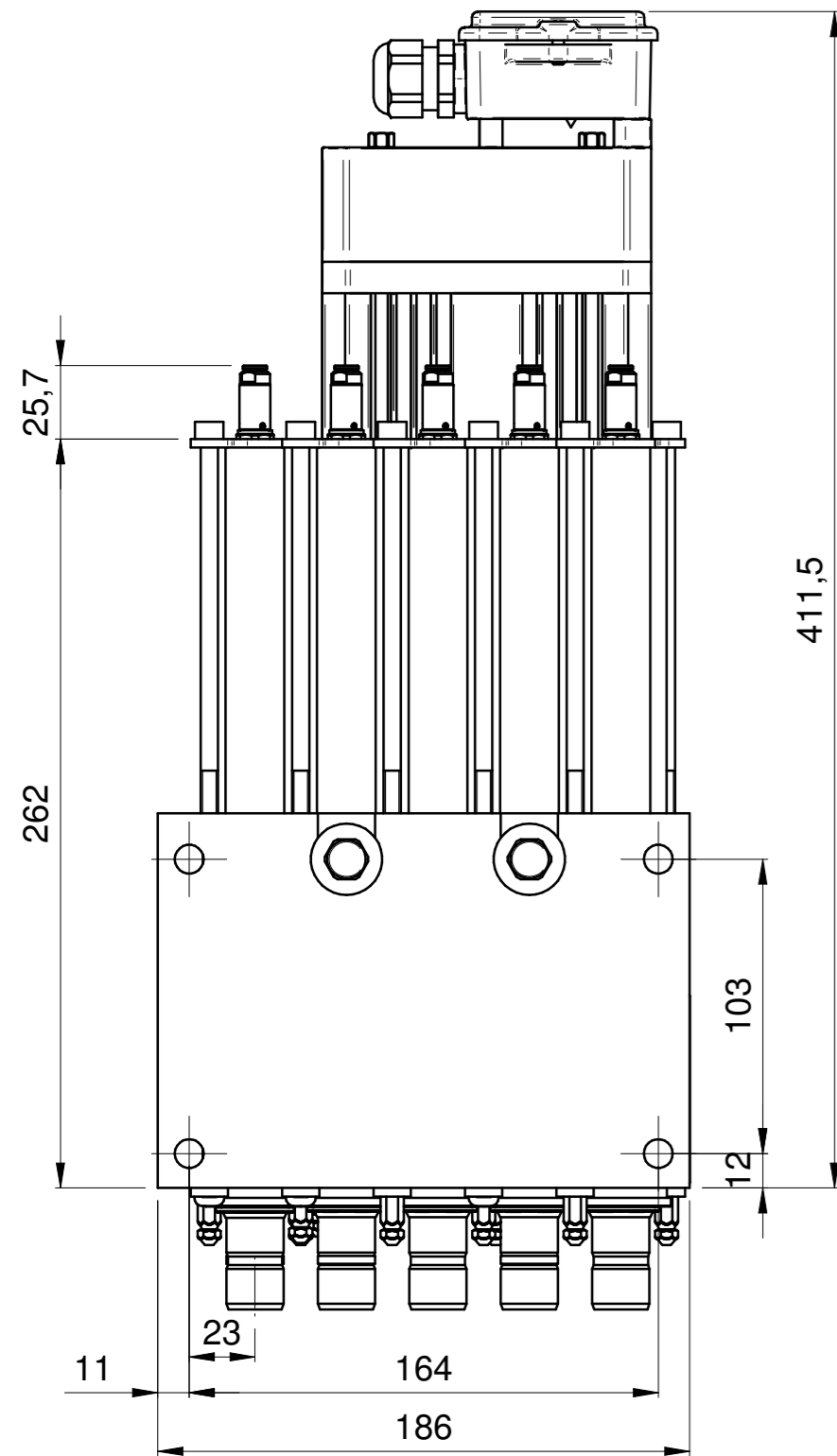

Firma / Signature	Data / Date	Rev	Data / Date	Firma / Signature	N° Modifica / Change ID
Controllato / Checked					
Disegnato / Designed	L.Perrotti	05/09/2019			
Descrizione ultima modifica / Last change description					
Denominazione / Item Name					
TESTA FORATURA 9 MV+0 MO+0 LAME VANTAGE IND					
Scala / Scale	Codice / Item ID	Rev	Status	Tav. N. di N.	
1:2	29L0557495F	01		1/3	

Template version: 12
© RISERVAMO A TERMINI DI LEGGE LA PROPRIETA' DI QUESTO DISEGNO CON DIVIETO DI RENDERSILO COMUNE E NOTO A TERZI SENZA LA NOSTRA PREVENTIVA APPROVAZIONE. / THIS DRAWING IS OUR PROPERTY. COPYRIGHTED MATERIAL DISCLOSURE TO THIRD PARTIES WITHOUT OUR AUTHORISATION IS EXPLICITLY FORBIDDEN.