

ATC
ELETTROMANDRINI
ATC
ELECTROSPINDLES



ADVANCED
MATERIALS

PLASTIC

LIGHT
ALLOY

WOOD

HITECO
HIGH TECHNOLOGY COMPONENTS

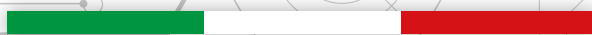

Componenti ad **alta tecnologia** per produttori di macchine utensili.

--
High-tech components for machine tool manufacturers.

Hiteco è specializzata nella progettazione e realizzazione di componenti elettromeccanici industriali ad alta tecnologia per le macchine utensili.

Elettromandrini A.T.C., elettromandrini M.T.C, teste birotative, teste di foratura ed aggregati.

--
Hiteco is specialized in design and manufacture of high technology industrial electromechanical components for machine tools. **A.T.C. electrospindles, M.T.C. electrospindles, birotary heads, boring units and aggregates.**



Hiteco si propone sul mercato internazionale con un'ampia gamma di prodotti per la lavorazione di: **legno, plastica, materiali avanzati, vetro, pietra e metallo.**

--
Hiteco offers a wide range of products on international market for **wood, plastic, advanced materials, glass, stone and metal processing.**



Hiteco nasce nel 1977 come divisione interna di **SCM Group**, azienda leader mondiale nella costruzione di macchine utensili per la lavorazione di una vasta gamma di materiali, realizzando un percorso di crescita esponenziale. Diventa nel 2008 **un'unità di profitto per servire il mercato terzi**. Oggi realizza prodotti di riferimento nel mercato dei componenti, diventando uno tra i più importanti player mondiali nel settore.

--
Hiteco founded in 1977 as an internal division of the **SCM Group**, leading company in machine tools construction for processing a wide range of materials, had an increasingly exponential growth. In 2008 it become **a profit unit for external customers**. Today Hiteco offers key products for the components market, becoming one of the most important world players in the sector.



Una **presenza capillare** per un **servizio best-in-class e worldwide.**

--
A capillary presence for a **best-in-class** and **worldwide service.**

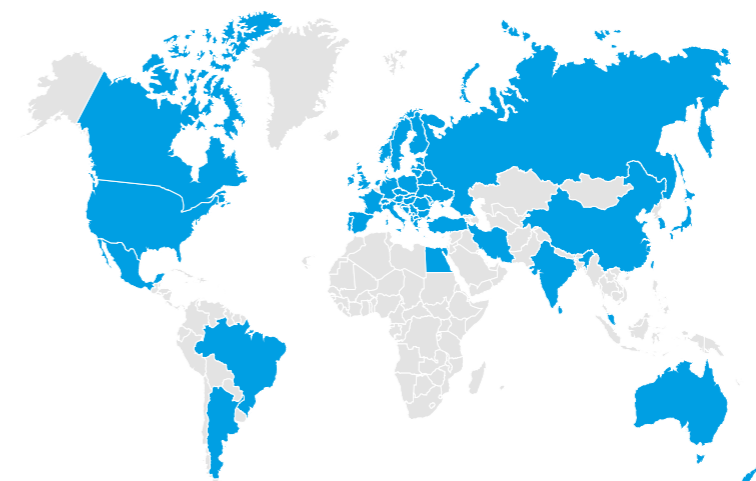

La distribuzione capillare dell'azienda risponde alla volontà di Hiteco di essere vicina al cliente con la presenza sul territorio di **tecnici specializzati** che sono garanzia di una risposta estremamente rapida e professionale: non solo per ridurre fermi macchina e problemi alla produzione, ma anche per creare valore aggiunto con la proposta di soluzioni efficaci ed innovative. Questa attenzione, oltre ai ridotti tempi di consegna, è uno dei motivi che ha portato Hiteco ad avere la più alta **customer satisfaction** nel mercato internazionale.

--
The widespread distribution of the company responds to the desire of Hiteco to be close to the customer with the presence of **specialized technicians** on the territory who guarantee an extremely rapid and professional response: not only to reduce machine downtimes and production problems, but also to create added value with the proposal of effective and innovative solutions. Such care, in addition to reduced delivery times, is one of the reason that led Hiteco to have the highest **customer satisfaction** on the international market.



INDICE INDEX



Hiteco si riserva il diritto di apportare migliorie sulle tecnologie e i modelli presentati nel catalogo
Hiteco reserves the right to make improvements to the technologies and models presented in the catalog

Copyright © Hiteco. Tutti i diritti riservati
Copyright © Hiteco. All rights reserved

IDENTIFICAZIONE ELETTROMANDRINI / ELECTROSPINDLE IDENTIFICATION KEY

Example **QE 1F 10/TI 24 63F NC CB EN BT OQ IS**

MODELLO (DIMENSIONE CARCASSA) / MODEL (HOUSING DIMENSION)

QD	102 X 119,5 mm
	110 X 111 mm
QE	130 X 140 mm
QF	150 X 160 mm
QM	215 X 245 mm, 230x230 mm
QX	130 X 130 mm
PX	150 X 150 mm
HX	150 X 150 mm
QT	150 X 150 mm
HT	150 X 150 mm
HD	130 X 130 mm
KX	Ø 202 mm
ML/MA	Ø 158, Ø 166, 135 x 137, 157 x 165
MG	200 X 200 mm
QN	102 X 119,5 mm
MQH1	205 X 175 mm
XS	70 X 65 mm

RAFFREDDAMENTO / COOLING TYPE

1F= ELETTOVENTOLA / ELECTROFAN	
1C= ARIA COMPRESSA / COMPRESSED AIR	
2= LIQUIDO / LIQUID	
1= VENTOLA SU ALBERO / FAN ON SHAFT	

POTENZA NOMINALE (S1) @ VELOCITÀ / RATED POWER (S1) @ SPEED

MAX POTENZA @ VELOCITÀ / MAX POWER @ SPEED

VELOCITÀ MAX / MAX SPEED

ATTACCO UTENSILE / TOOL HOLDER

63F = HSK63F
32E = HSK32E
40E = HSK40E
63E = HSK63E
85S = HSK85S
80F = HSK80F
63A = HSK63A
130 = ISO30
140 = ISO40
ER25
ER32
ER40
ALBERO / SHAFT, D=12, 16, 30, 40, 50

NASO MANDRINO / SPINDLE NOSE

NC= NASO CORTO / SHORT NOSE
NL= NASO LUNGO / LONG NOSE
CH = COMPACT SHORT NOSE
LH = COMPACT LONG NOSE

CONNESSIONE ELETTRICA / ELECTRIC CONNECTION

CB= CONNESSIONE BASE / BASIC CONNECTION
CC= CONNESSIONE CIRCOLARE / CIRCULAR CONNECTION
PP= CONNESSIONE RAPIDA / PLUG AND PLAY CONNECTION
SC= SENZA CONNETTORE / FLYING CABLE

ENCODER

ES= ENCODER 1 VPP (SYNUSOIDAL WAVE)
EN= ENCODER TTL (SQUARE WAVE)

VOLTAGGIO / VOLTAGE

BT= BITENSIONE / DUAL VOLTAGE 220V/380V
220 V

OPTIONAL

OQ=OIL MIST+MQL (Minimal Quantity Lubrication)
AT= AIR TOOL
OM= OIL MIST
CTS= LUBRIFICAZIONE CTS / COOLANT THROUGH THE SHAFT

ALTRE VARIANTI / OTHER VARIANTS

SENSORE DI VIBRAZIONE / VIBRATION SENSOR		
MONITORAGGIO TEMPERATURA CUSCINETTI / BEARING TEMPERATURE MONITORING		
MISURATORE DI VELOCITÀ / SPEED MONITORING		
SS - SENSORE RITORNO PISTONE / PISTON BACK SENSOR		
SENSORE DI TEMPERATURA / TEMPERATURE SENSOR		
iSPINDLE - DIGITAL COMMUNICATION ON FIELDBUS / COMUNICAZIONE DIGITALE SENSORI SU FIELDBUS		

INDICE POTENZE / POWER INDEX

POWERTECH	POWERTECH 210	POWERTECH 260	POWERTECH 300 COMPACT	POWERTECH 300	POWERTECH 400 HS	POWERTECH 400	POWERTECH 500	POWERTECH 600
POWER @RPM - MAX SPEED								
4/12 24	p. 9		p. 15					
5.5/6 20 (HT)						p. 23		
5.5/12 24			p. 15	p. 17				
6.5/12 36 (HS)		p. 11						
6.5/12 40 (HS)		p. 12						
6.6/12 24				p. 17				
7.5/6 24 (HT)						p. 23		
8/9 18 (HT)							p. 31	
8/12 24				p. 18 - 19				
8/12 28 (HS)					p. 21			
8/12 36 (HS)		p. 11						
8/12 40 (HS)		p. 12						
8.5/6 24 (HT)						p. 24		
8.5/12 24						p. 25		
9/6 24 (HT)						p. 27		
9.5/12 24				p. 19				
10/11 24						p. 25		
11/6 10 (HT)								p. 35
11/6 24 (HT)						p. 27		
11/12 20							p. 32	
12/6 18 (HT)							p. 33	
12/12 24						p. 26		
13/7 15 (HT)							p. 31	
13/12 24						p. 28		
16/12 24						p. 28		
18/6 12 (HT)								p. 35
18/12 20							p. 33	

HS= HIGH SPEED
HT= HIGH TORQUE

INDICE POTENZE / POWER INDEX

ROBOTECH	ROBOTECH QX	ROBOTECH QX HS	ROBOTECH PX-HX	ROBOTECH HX 3C	ROBOTECH HD	ROBOTECH QT	ROBOTECH HT	ROBOTECH QM	ROBOTECH QM 3C
5.6/18 20					p. 51				
5/12 21	p. 38								
8/15 36 (HS)		p. 41							
8/15 40 (HS)		p. 41							
8.5/12 24	p. 37								
10/7 24 (HT)			p. 43	p. 47					
10/12 24	p. 37								
11/10 24 (HT)	p. 39	p. 42							
11/12 24	p. 38								
12/12 24			p. 44	p. 47					
13/7 24 (HT)			p. 43	p. 47					
13/6 16 (HT)						p. 53			
15/12 24			p. 44	p. 48					
16/6 16 (HT)						p. 53			
18/12 24			p. 45	p. 49					
20/10 24			p. 45	p. 49					
25/7 16 (HT)						p. 54			
25/10 18							p. 57		
25/10 24							p. 57		
30/6 13 (HT)								p. 59	p. 61
44/6 13 (HT)								p. 59	p. 61

METALTECH	METALTECH KX	METALTECH MX
31/3 15	p. 63	
32/4.5 24	p. 63	
42/6 18 (HT)		p. 65
42/6 24 (HT)		p. 65
42/12 20		p. 66
42/12 28		p. 66

STONETECH	STONETECH MG
9/6 15	p. 69
13.5/6 15	p. 69
30/7.5 12	p. 70



ADDITIONAL EQUIPMENT	
C-AXIS FOR POWERTECH 300-400	p. 72
REFERENCE SLEEVE	p. 72
TOOL HOLDER	p. 73
TOOL FINGER	p. 73
HEAT EXCHANGER	p. 73

POWERTECH 210



SUITABLE FOR MACHINING WOOD, PLASTICS AND COMPOSITES
 REDUCED SPACE REQUIRED AND FIXING FLEXIBILITY (AVAILABLE ON 2 SIDES)
 AVAILABLE WITH ISO 30, HSK 63F AND DUAL VOLTAGE
 CERAMIC BEARINGS
 EASY MAINTENANCE

QD-1F 4/12 24

PRESTAZIONI / PERFORMANCES

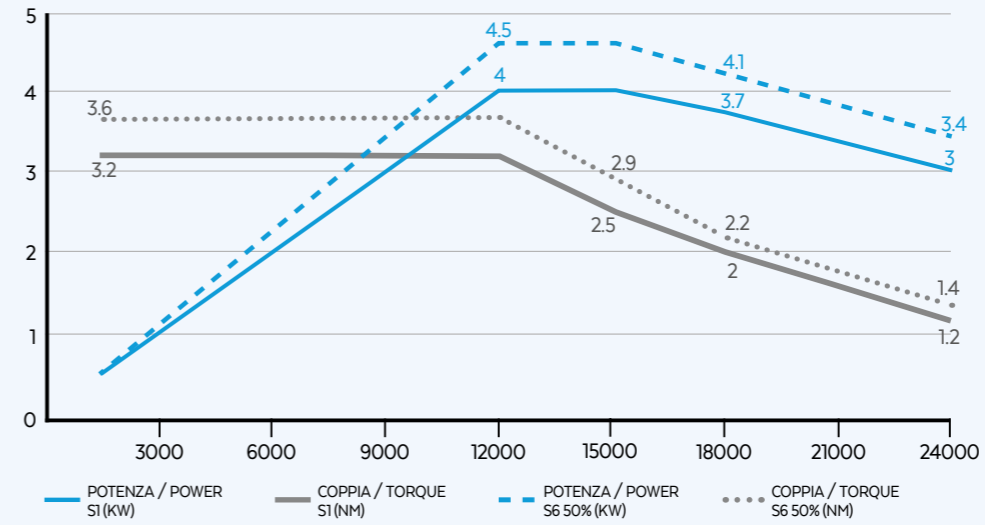

OPZIONALI / OPTIONS

- Circular connector CC
- HSK 63F
- Plug & Play
- COM-PRESSED AIR
- Anti-rotation sleeves
- Bearings temperature monitoring
- Speed monitoring
- Vibration sensor
- Dual voltage 220V-380V

SPECIFICHE TECNICHE / TECHNICAL SPECIFICATIONS

- S1-S6 kW 4/4.5
- S1-S6 A 9/10.7
- Pol es 4
- S1-S6 Nm 3.2/3.6
- Volt 380
- Supply inverter
- rpm 24000
- kg 18

EQUIPAGGIAMENTO / EQUIPMENT

- ISO 30
- Ceramic ball bearings
- Labyrinth with air seal
- Electrofan cooling
- Grease lubrication
- Double effect pneumatic cylinder
- Sensors s1, s2, s3
- Automatic tool change (A.T.C)
- Taper cleaning

LAYOUT HSK 63F CB

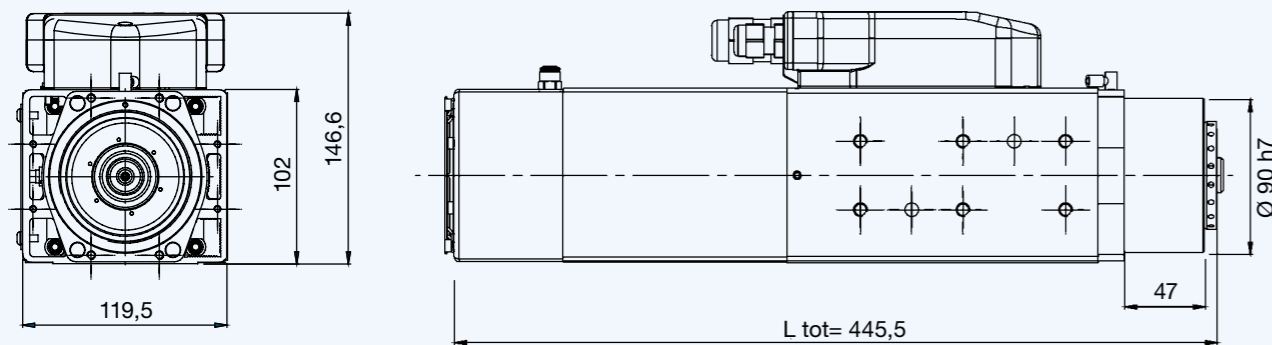

ALTRI LAYOUT / OTHER LAYOUTS

	ΔL	L tot
ISO 30	+6,9 mm	452,40 mm
Aria compressa / Compressed air	ISO30= -29,1 mm	416,4 mm
	HSK63F= -36,0 mm	409,5 mm



POWERTECH 260



SUITABLE FOR MACHINING ALUMINUM, PLASTICS AND LIGHT ALLOYS
 VERY STRONG SPINDLES WITH SPEEDS UP TO 40K RPM
 5 BEARINGS FOR HIGH STIFFNESS
 SUITABLE FOR 3 AND 5-AXIS MACHINES

LAYOUT HSK40E / HSK32E CC

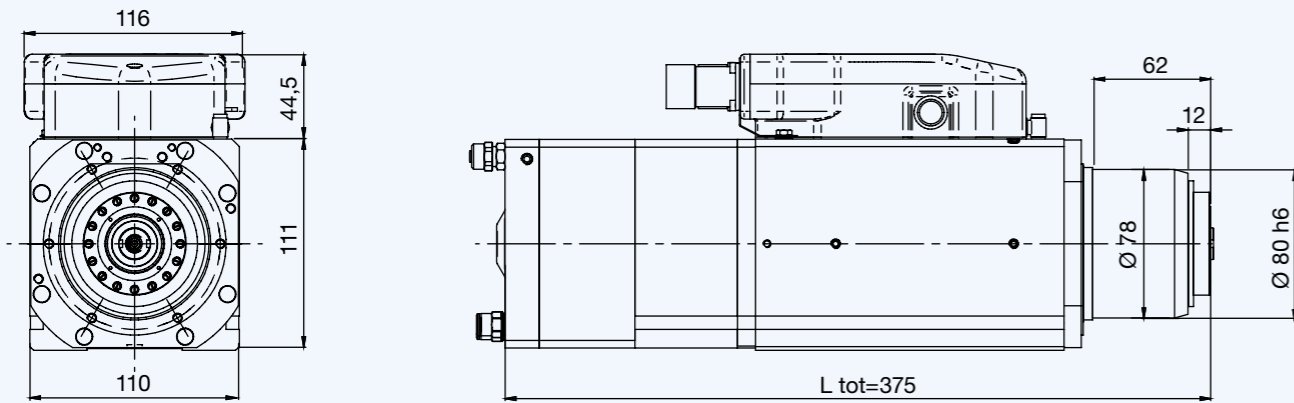

LAYOUT HSK40E / HSK32E SC

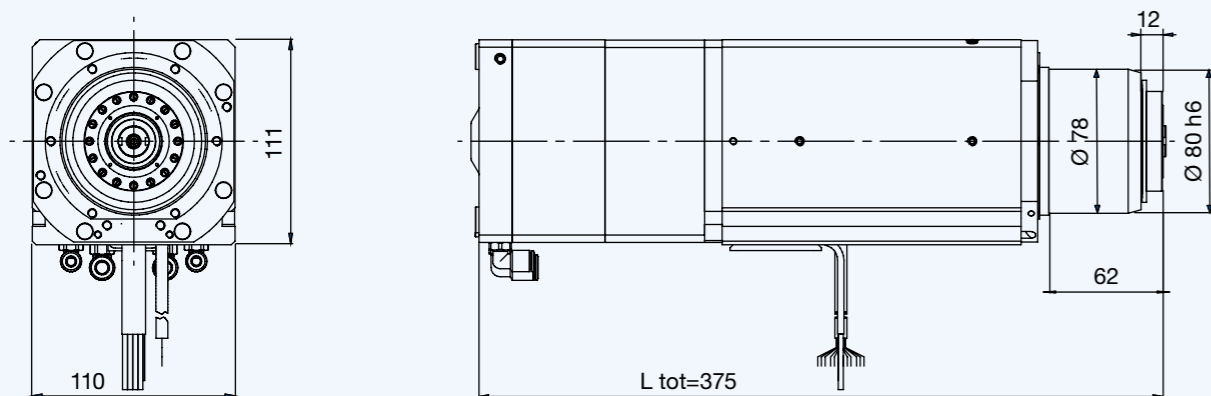

QD-2 6.5/12 36

HIGH SPEED

PRESTAZIONI / PERFORMANCES

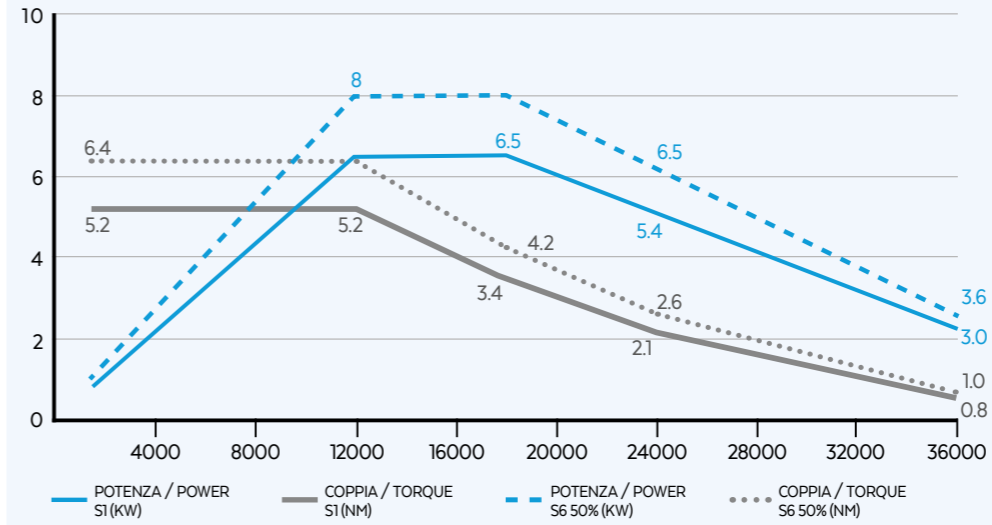

OPZIONALI / OPTIONS

- Encoder TVpp or TTL
- Quick connection PP
- HSK 32E
- Circular connector cc machine side
- Anti-rotation sleeves
- Bearings temperature monitoring
- Speed monitoring
- Vibration sensor
- Temperature sensor

SPECIFICHE TECNICHE / TECHNICAL SPECIFICATIONS

- S1-S6 kW 6.5/8
- S1-S6 Nm 5.2/6.4
- S1-S6 rpm 36000
- S1-S6 A 20.5/23
- Volt 380
- kg 17
- Pol es 4
- Supply inverter

EQUIPAGGIAMENTO / EQUIPMENT

- HSK 40E
- Ceramic ball bearings
- Circular connector spindle side
- Liquid cooling
- Labyrinth with air seal
- Taper cleaning

- Double effect pneumatic cylinder
- Grease lubrication
- Automatic tool change (A.T.C)
- Sensors s1,s2,s3,s5

QD-2 8/12 36

HIGH SPEED

PRESTAZIONI / PERFORMANCES

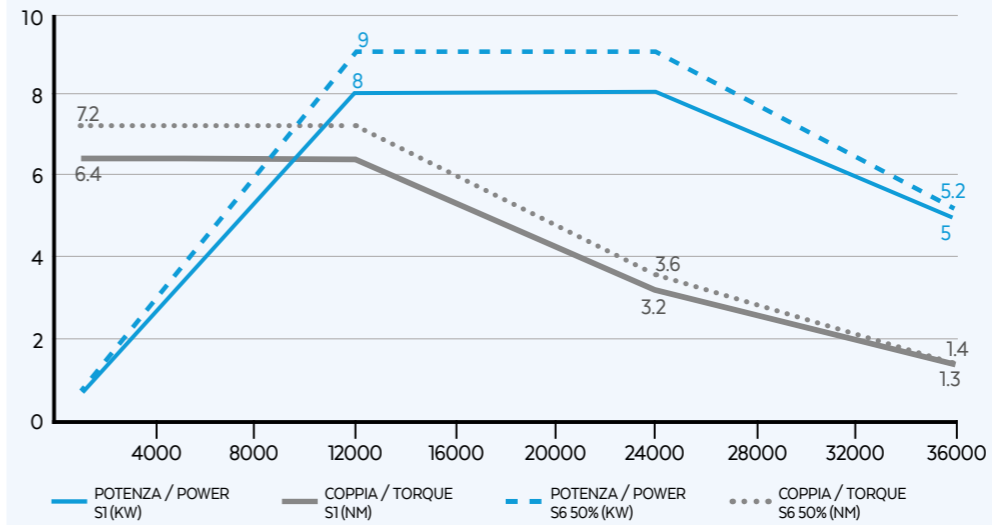

OPZIONALI / OPTIONS

- Encoder TVpp or TTL
- Quick connection PP
- HSK 32E
- Circular connector cc machine side
- Anti-rotation sleeves
- Bearings temperature monitoring
- Speed monitoring
- Vibration sensor
- Temperature sensor

SPECIFICHE TECNICHE / TECHNICAL SPECIFICATIONS

- S1-S6 kW 8/9
- S1-S6 Nm 6.4/7.2
- S1-S6 rpm 36000
- S1-S6 A 24/26
- Volt 380
- kg 17
- Pol es 4
- Supply inverter

EQUIPAGGIAMENTO / EQUIPMENT

- HSK 40E
- Ceramic ball bearings
- Circular connector spindle side
- Liquid cooling
- Labyrinth with air seal
- Taper cleaning

- Double effect pneumatic cylinder
- Grease lubrication
- Automatic tool change (A.T.C)
- Sensors s1,s2,s3,s5

QD-2 6.5/12 40

HIGH SPEED

PRESTAZIONI / PERFORMANCES

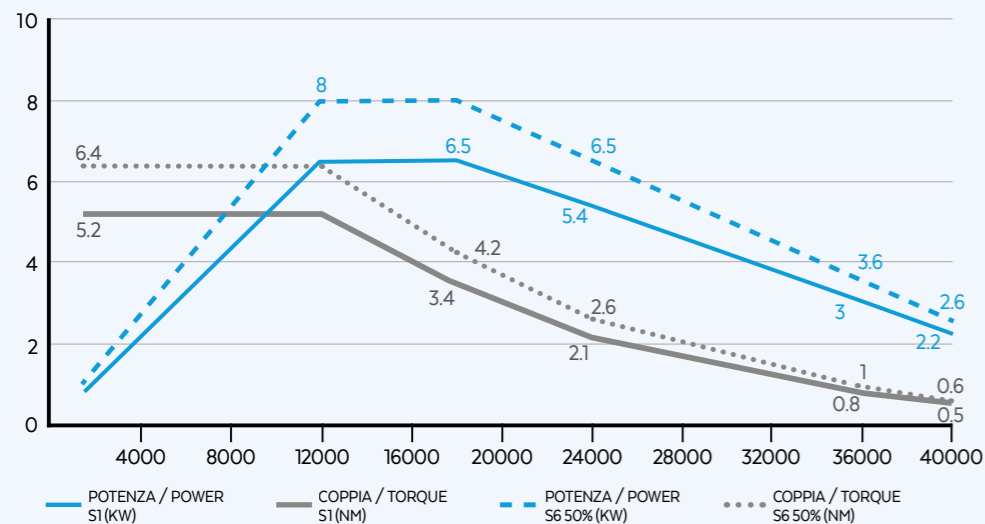

OPZIONALI / OPTIONS

- Encoder TVpp or TTL
- Quick connection PP
- Vibration sensor
- Temperature sensor
- Bearings temperature monitoring
- Speed monitoring
- Circular connector cc machine side
- Anti-rotation sleeves

SPECIFICHE TECNICHE / TECHNICAL SPECIFICATIONS

- Power: 6.5/8 kW
- Current: 20.5/23 A
- Pol: 4
- Power: 5.2/6.4 Nm
- Voltage: 380 Volt
- Supply: inverter
- Speed: 40000 rpm
- Weight: 17 kg

EQUIPAGGIAMENTO / EQUIPMENT

- HSK 32E
- Liquid cooling
- Double effect pneumatic cylinder
- Automatic tool change (A.T.C)
- Ceramic ball bearings
- Labyrinth with air seal
- Grease lubrication
- Sensors s1, s2, s3, s5
- Circular connector spindle side
- Taper cleaning

QD-2 8/12 40

HIGH SPEED

PRESTAZIONI / PERFORMANCES

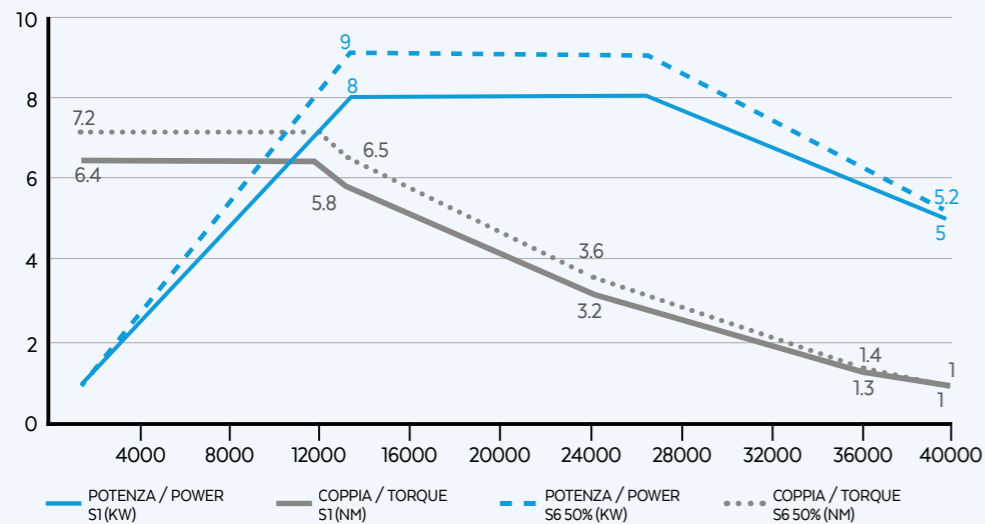

OPZIONALI / OPTIONS

- Encoder TVpp or TTL
- Quick connection PP
- Vibration sensor
- Temperature sensor
- Bearings temperature monitoring
- Speed monitoring
- Circular connector cc machine side
- Anti-rotation sleeves

SPECIFICHE TECNICHE / TECHNICAL SPECIFICATIONS

- Power: 8/9 kW
- Current: 24/26 A
- Pol: 4
- Power: 6.4/7.2 Nm
- Voltage: 380 Volt
- Supply: inverter
- Speed: 40000 rpm
- Weight: 17 kg

EQUIPAGGIAMENTO / EQUIPMENT

- HSK 32E
- Liquid cooling
- Double effect pneumatic cylinder
- Automatic tool change (A.T.C)
- Ceramic ball bearings
- Labyrinth with air seal
- Grease lubrication
- Sensors s1, s2, s3, s5
- Circular connector spindle side
- Taper cleaning

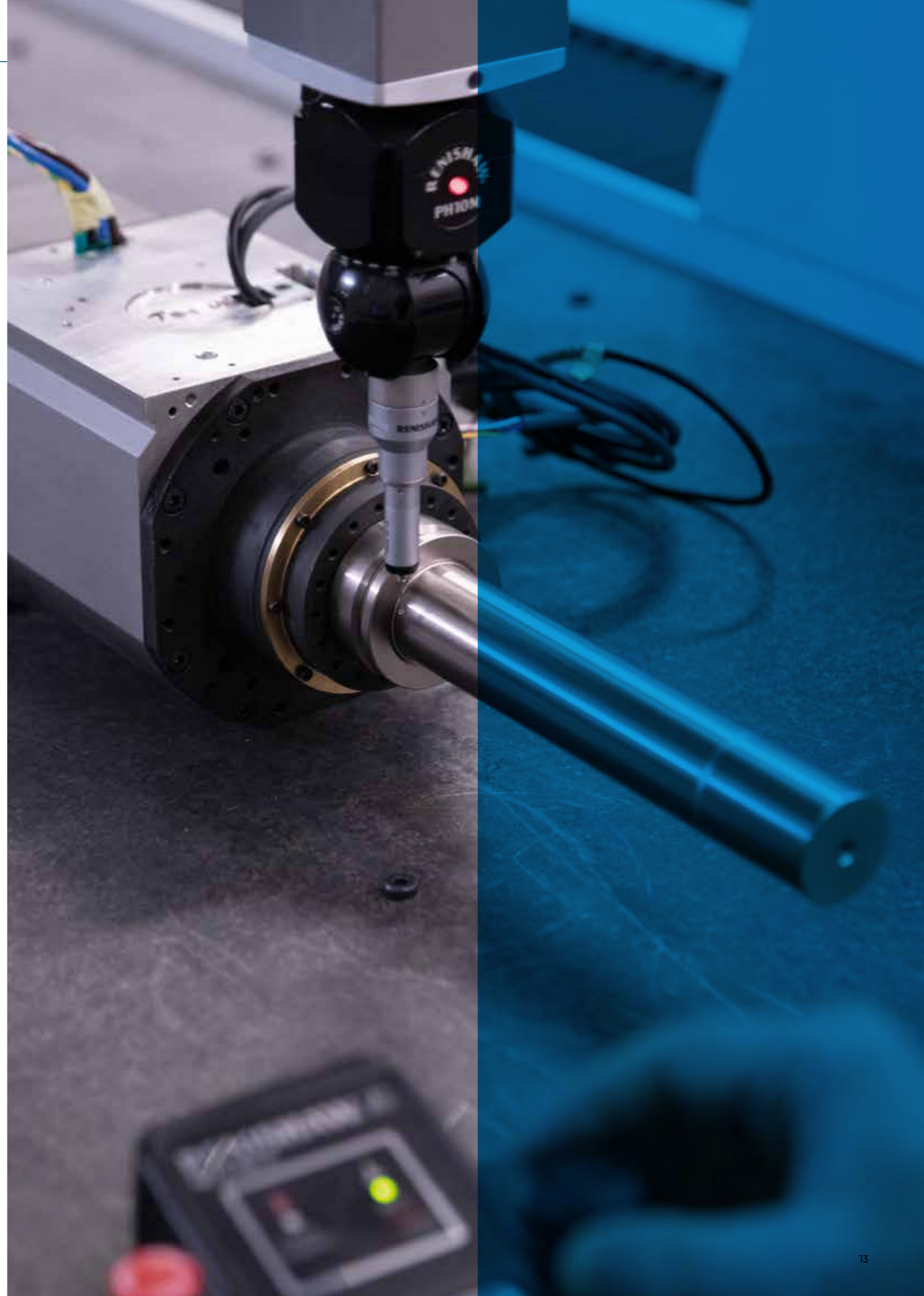

POWERTECH 300 COMPACT



SUITABLE FOR MACHINING WOOD, ALUMINUM AND PLASTICS
REDUCED SPACE REQUIRED
AVAILABLE WITH ISO 30, HSK 63F AND DUAL VOLTAGE
CERAMIC BEARINGS

LAYOUT ISO30 CB

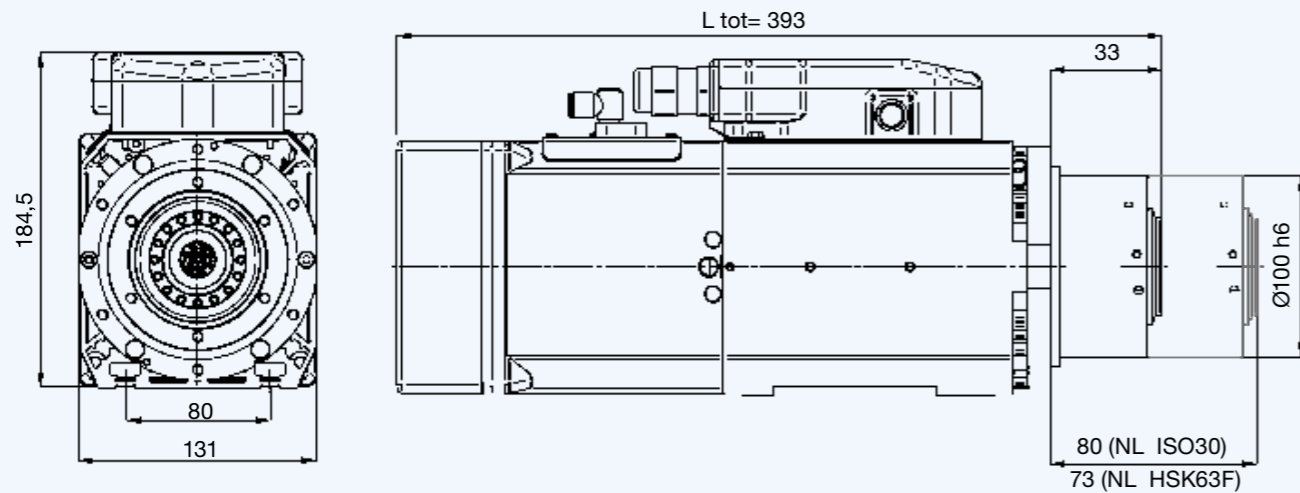

ALTRI LAYOUT / OTHER LAYOUTS

	ΔL	L tot
Aria compressa / Compressed air	ISO30= -44 mm	349 mm
	HSK63F= -44 mm	349 mm

QE-1F 4/12 24

PRESTAZIONI / PERFORMANCES

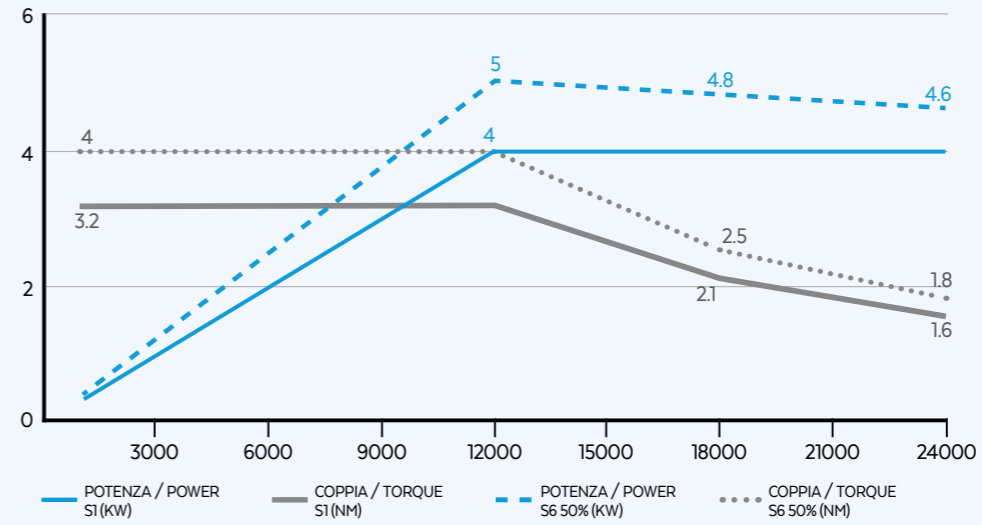

OPZIONALI / OPTIONS

- Encoder TVpp or TTL
- Circular connector CC
- Sensor s5
- Compressed air cooling
- Bearings temperature monitoring
- Speed monitoring
- Vibration sensor
- HSK 63F
- Anti-rotation sleeves

SPECIFICHE TECNICHE / TECHNICAL SPECIFICATIONS

- S1-S6 kW 4/5
- S1-S6 Nm 3.2/4
- rpm 24000
- S1-S6 A 8.5/10
- Volt 220/380
- kg 19
- Pol es 2
- Supply inverter

EQUIPAGGIAMENTO / EQUIPMENT

- ISO 30
- Ceramic ball bearings
- Grease lubrication
- Electrofan cooling
- Labyrinth with air seal
- Single effect pneumatic cylinder
- Sensors s1, s2, s3
- Automatic tool change (A.T.C)
- Taper cleaning

QE-1F 5.5/12 24

PRESTAZIONI / PERFORMANCES

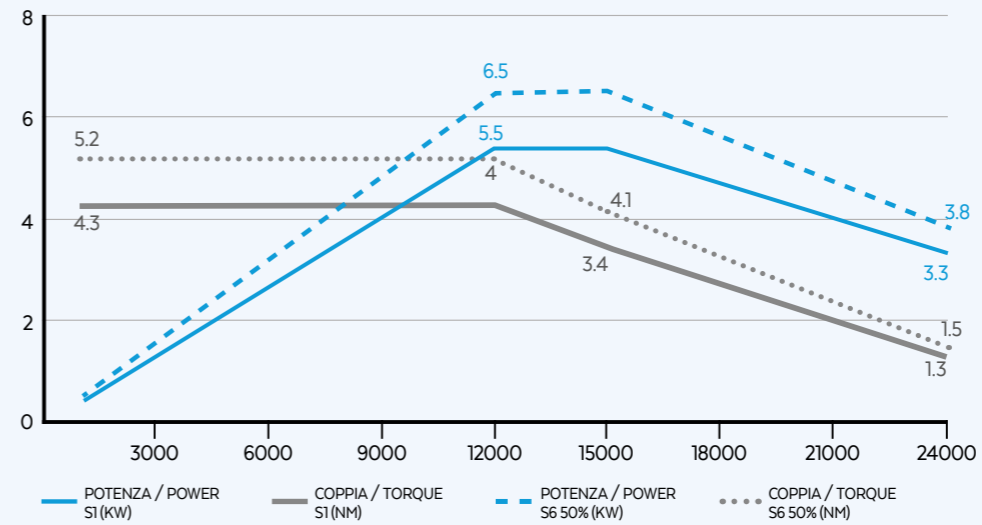

OPZIONALI / OPTIONS

- Encoder TVpp or TTL
- Circular connector CC
- Sensor s5
- Compressed air cooling
- Bearings temperature monitoring
- Speed monitoring
- Vibration sensor
- HSK 63F
- Anti-rotation sleeves

SPECIFICHE TECNICHE / TECHNICAL SPECIFICATIONS

- S1-S6 kW 5.5/6.5
- S1-S6 Nm 4.3/5.2
- rpm 24000
- S1-S6 A 11/13
- Volt 220/380
- kg 19
- Pol es 4
- Supply inverter

EQUIPAGGIAMENTO / EQUIPMENT

- ISO 30
- Ceramic ball bearings
- Grease lubrication
- Electrofan cooling
- Labyrinth with air seal
- Single effect pneumatic cylinder
- Sensors s1, s2, s3
- Automatic tool change (A.T.C)
- Taper cleaning

POWERTECH 300



SUITABLE FOR MACHINING WOOD, PLASTICS AND COMPOSITES
WIDE RANGE OF POWER FOR ANY TYPE OF MACHINING
AVAILABLE WITH LIQUID COOLING FOR HEAVY AND INTENSIVE PROCESSES
EASY MAINTENANCE

LAYOUT HSK 63F CB

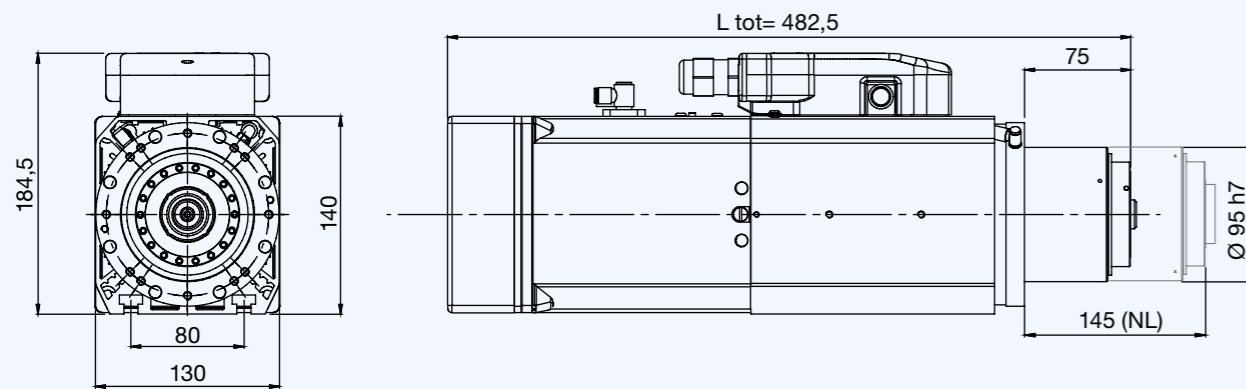

ALTRI LAYOUT / OTHER LAYOUTS

	ΔL	L tot
ISO 30	+6,9 mm	489,4 mm
Aria compressa / Compressed air	ISO30= -44 mm HSK63F= -44 mm	438,5 mm
Encoder (1 Vpp or TTL)	ISO30= +7 mm HSK= +7 mm	496,4 mm 489,5 mm

QE-1F 5.5/12 24

PRESTAZIONI / PERFORMANCES

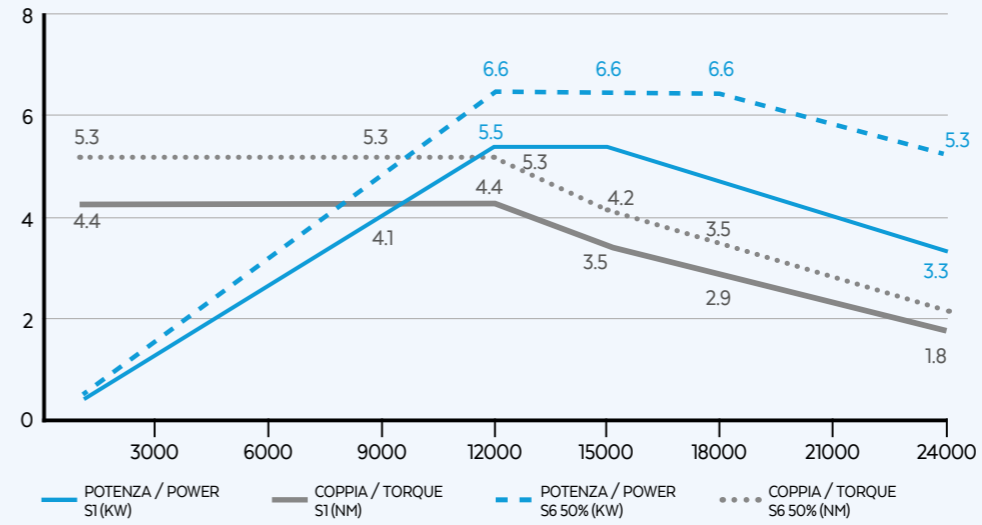

OPZIONALI / OPTIONS

- Encoder TVpp or TTL
- Circular connector CC
- Quick connection PP
- Long nose
- Air tool
- ISO 30
- Anti-rotation sleeves
- Bearings temperature monitoring
- Speed monitoring
- Vibration sensor
- C-AXES available
- iSPINDLE
- Compressed air cooling

SPECIFICHE TECNICHE / TECHNICAL SPECIFICATIONS

- S1-S6 kW: 5.5/6.6
- S1-S6 Nm: 4.4/5.3
- S1-S6 rpm: 24000
- S1-S6 A: 13.5/14.5
- Volt: 380
- kg: 21
- Pol es: 4
- Supply: inverter

EQUIPAGGIAMENTO / EQUIPMENT

- HSK 63F
- Ceramic ball bearings
- Taper cleaning
- Electrofan cooling
- Labyrinth with air seal
- Grease lubrication
- Double effect pneumatic cylinder
- Sensors s1, s2, s3, s5
- Automatic tool change (A.T.C)

QE-1F 6.6/12 24

PRESTAZIONI / PERFORMANCES

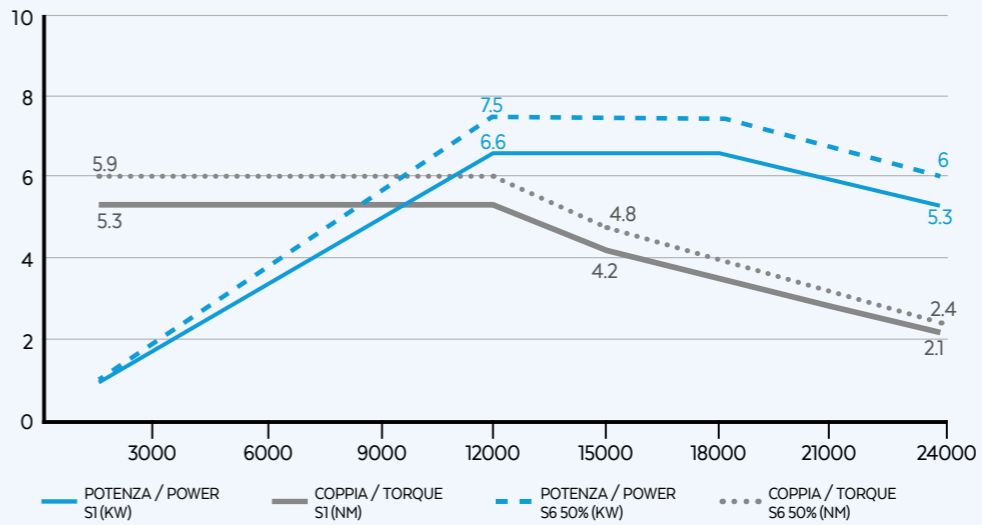

OPZIONALI / OPTIONS

- Encoder TVpp or TTL
- Circular connector CC
- Quick connection PP
- Long nose
- Air tool
- ISO 30
- Dual voltage 220V-380V
- Anti-rotation sleeves
- Bearings temperature monitoring
- Speed monitoring
- Vibration sensor
- C-AXES available
- Compressed air cooling
- iSPINDLE
- Automatic tool change (A.T.C)
- Sensors s1, s2, s3, s5

SPECIFICHE TECNICHE / TECHNICAL SPECIFICATIONS

- S1-S6 kW: 6.6/7.5
- S1-S6 Nm: 5.3/5.9
- S1-S6 rpm: 24000
- S1-S6 A: 14.5/16
- Volt: 380
- kg: 21
- Pol es: 4
- Supply: inverter

EQUIPAGGIAMENTO / EQUIPMENT

- HSK 63F
- Ceramic ball bearings
- Taper cleaning
- Electrofan cooling
- Grease lubrication
- Double effect pneumatic cylinder
- Labyrinth with air seal
- Sensors s1, s2, s3, s5
- Automatic tool change (A.T.C)

QE-1F 8/12 24

PRESTAZIONI / PERFORMANCES

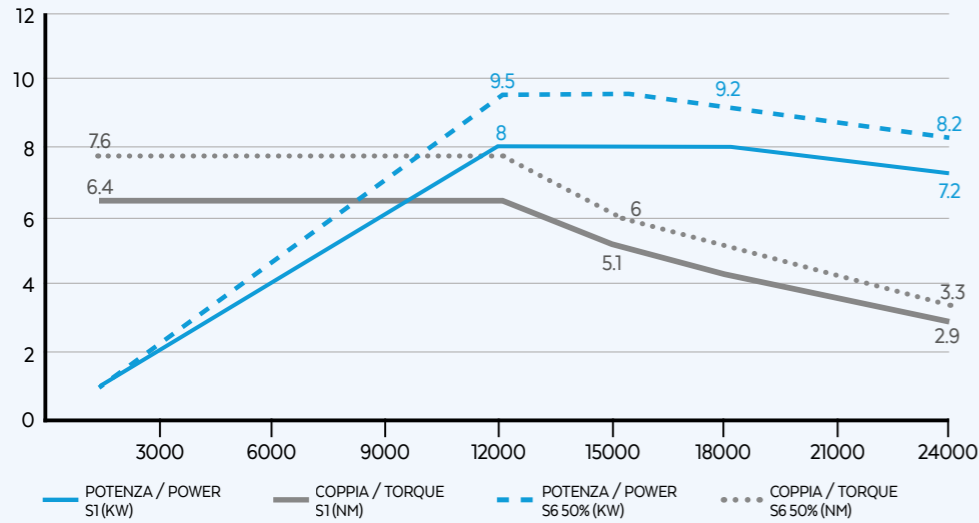

OPZIONALI / OPTIONS

- Circular connector CC
- Quick connection PP
- Long nose
- Air tool
- Encoder TVpp or TTL
- ISO 30
- Dual voltage 220V-380V
- Bearings temperature monitoring
- Speed monitoring
- Vibration sensor
- C-axis available
- Compressed air cooling
- iSPINDLE
- Anti-rotation sleeves

SPECIFICHE TECNICHE / TECHNICAL SPECIFICATIONS

S1-S6 kW 8/9.5
S1-S6 Nm 6.4/7.6
rpm 24000
S1-S6 A 18.5/20.5
Volt 380
kg 21
Pol es 4
Supply inverter

EQUIPAGGIAMENTO / EQUIPMENT

HSK 63F
Ceramic ball bearings
Grease lubrication
Electrofan cooling
Labyrinth with air seal
Double effect pneumatic cylinder
Sensors s1, s2, s3, s5
Automatic tool change (A.T.C)
Taper cleaning

LAYOUT ISO 30 PP

LIQUID

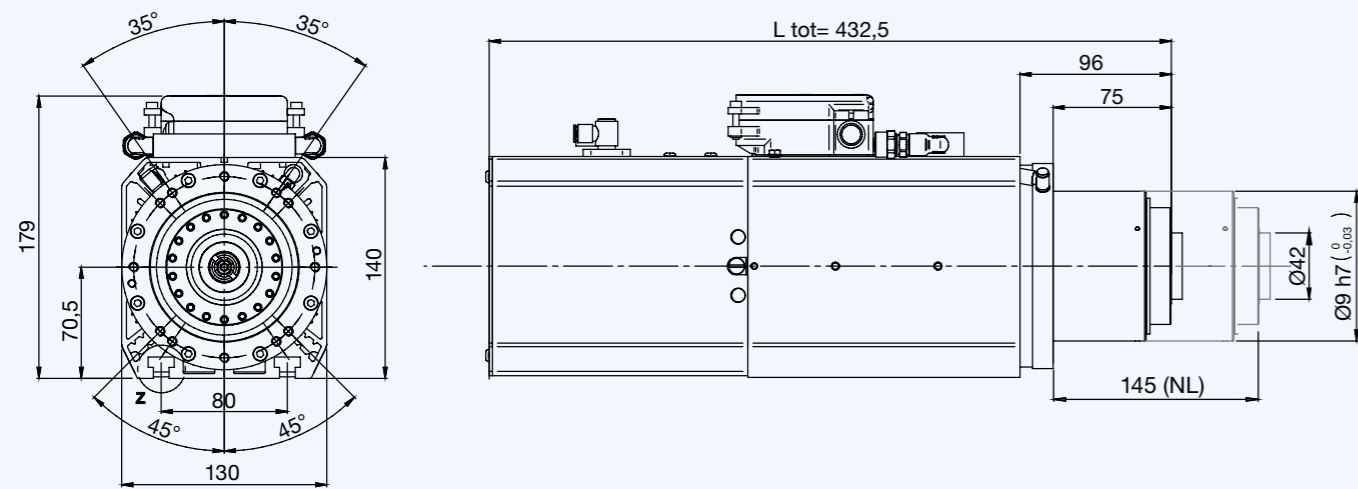

ALTRI LAYOUT / OTHER LAYOUTS

	ΔL	L tot
Encoder (1 Vpp or TTL)	ISO30= +7 mm	439,5 mm
HSK63F	0 mm	432,5 mm

QE-2 8/12 24

LIQUID

PRESTAZIONI / PERFORMANCES

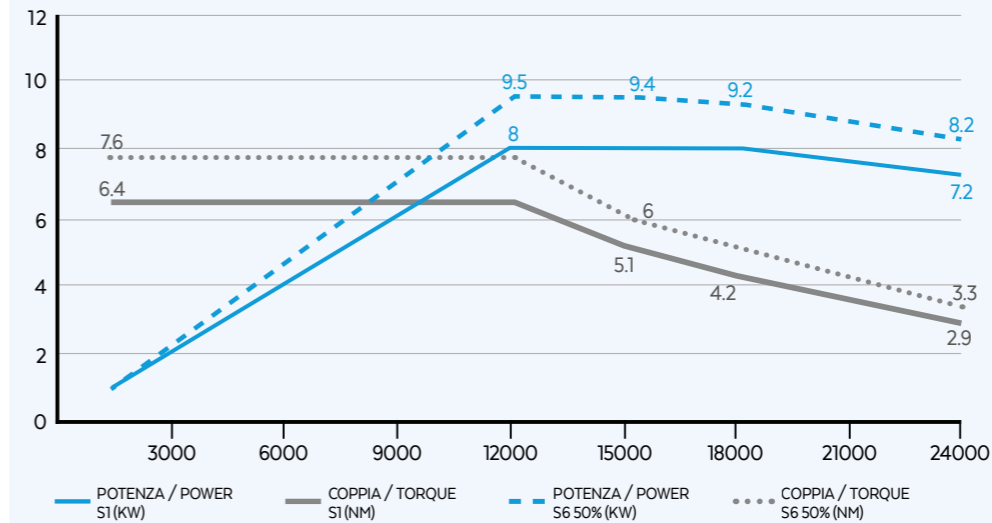

OPZIONALI / OPTIONS

- Encoder TVpp or TTL
- Long nose
- Air tool
- iSPINDLE
- Anti-rotation sleeves
- Bearings temperature monitoring
- Speed monitoring
- Vibration sensor
- C-axis available
- HSK 63F

SPECIFICHE TECNICHE / TECHNICAL SPECIFICATIONS

S1-S6 kW 8/9.5
S1-S6 Nm 6.4/7.6
rpm 24000
S1-S6 A 18.5/20.5
Volt 380
kg 21
Pol es 4
Supply inverter

EQUIPAGGIAMENTO / EQUIPMENT

ISO 30
Ceramic ball bearings
Taper cleaning
Liquid cooling
Labyrinth with air seal
Quick connection PP
Double effect pneumatic cylinder
Sensors s1, s2, s3, s5
Automatic tool change (A.T.C)
Grease lubrication

QE-2 9,5/12 24

LIQUID

PRESTAZIONI / PERFORMANCES

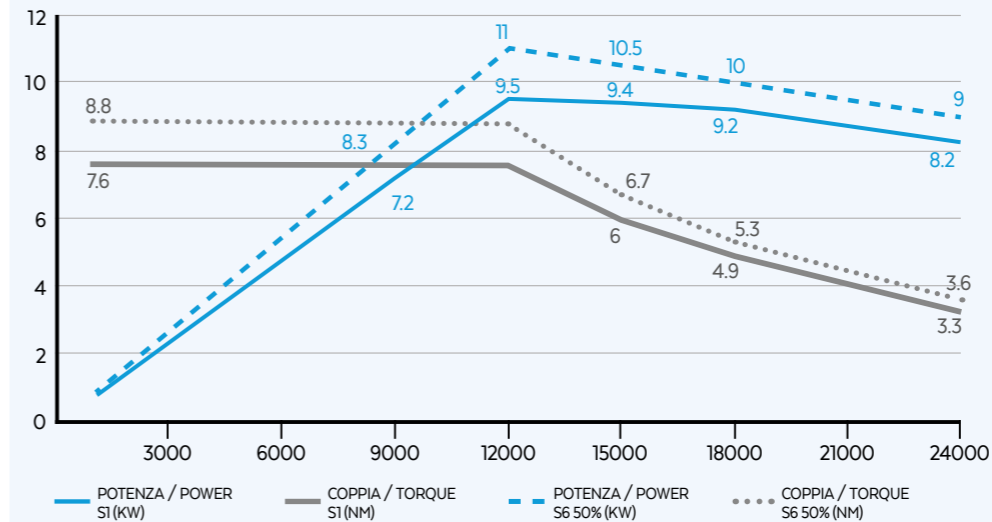

OPZIONALI / OPTIONS

- Encoder TVpp or TTL
- Long nose
- Air tool
- iSPINDLE
- Anti-rotation sleeves
- Bearings temperature monitoring
- Speed monitoring
- Vibration sensor
- C-axis available
- HSK 63F

SPECIFICHE TECNICHE / TECHNICAL SPECIFICATIONS

S1-S6 kW 9.5/11
S1-S6 Nm 7.6/8.8
rpm 24000
S1-S6 A 20.5/23
Volt 380
kg 21
Pol es 4
Supply inverter

EQUIPAGGIAMENTO / EQUIPMENT

ISO 30
Ceramic ball bearings
Taper cleaning
Liquid cooling
Labyrinth with air seal
Quick connection PP
Double effect pneumatic cylinder
Sensors s1, s2, s3, s5
Automatic tool change (A.T.C)
Grease lubrication

POWERTECH 400 HIGH SPEED



SUITABLE FOR MACHINING ALUMINUM AND COMPOSITES
LONG NOSE DESIGN TO GUARANTEE STRONG RIGIDITY
AIR COOLED SPINDLES WITH HIGH SPEED UP TO 28K RPM FOR FASTER FEED RATES
AVAILABLE WITH ISO 30, HSK 63F AND DUAL VOLTAGE

QE-1F 8/12 28

HIGH SPEED

PRESTAZIONI / PERFORMANCES

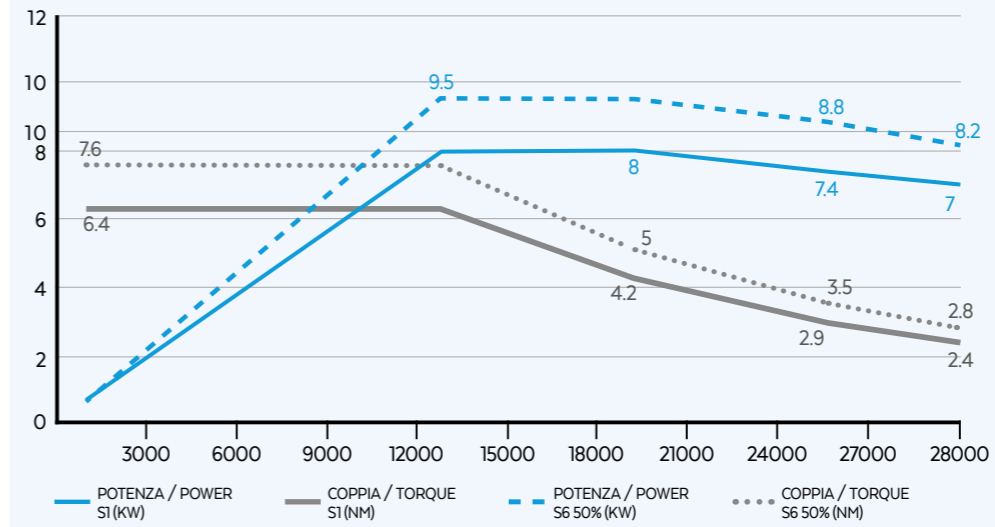

OPZIONALI / OPTIONS

- Encoder 1Vpp or TTL
- ISO 30
- Air tool
- Quick connection PP
- Dual voltage 220V-380V
- ISPINDE
- Bearings temperature monitoring
- Speed monitoring
- Vibration sensor
- C-axes available
- Circular connector cc machine side

SPECIFICHE TECNICHE / TECHNICAL SPECIFICATIONS

- 8/9
- 17/19
- 4
- 6.4/7.6
- 380
- inverter
- 28000
- 25

EQUIPAGGIAMENTO / EQUIPMENT

- HSK 63F
- Ceramic ball bearings
- Circular connector spindle side
- Electrofan cooling
- Labyrinth with air seal
- Taper cleaning
- Double effect pneumatic cylinder
- Sensors s1, s2, s3, s5
- Automatic tool change (A.T.C.)
- Grease lubrication

LAYOUT HSK 63F CC

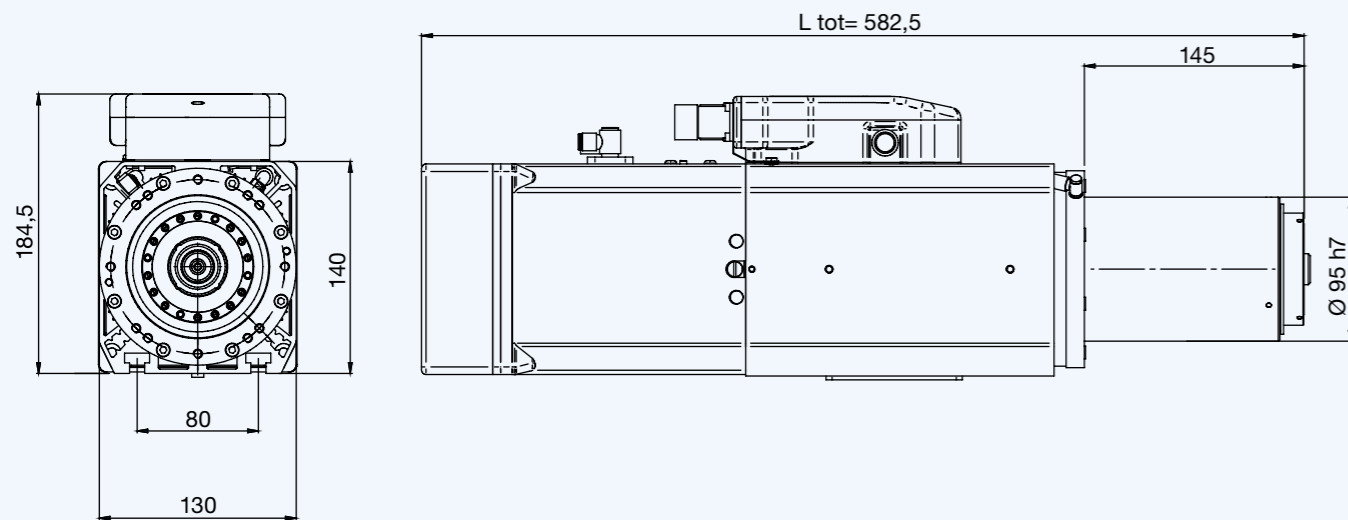

ALTRI LAYOUT / OTHER LAYOUTS

	ΔL	L tot
ISO 30	+6,9 mm	589,4 mm
Encoder (1 Vpp or TTL)	+7 mm	589,5 mm



POWERTECH 400



SUITABLE FOR MACHINING WOOD AND ALUMINUM
WIDE RANGE OF POWER UP TO 16 KW. HIGH TORQUE VERSIONS AVAILABLE
AVAILABLE WITH LIQUID COOLING FOR HEAVY AND INTENSIVE PROCESSES
EASY MAINTENANCE

LAYOUT HSK 63F CB

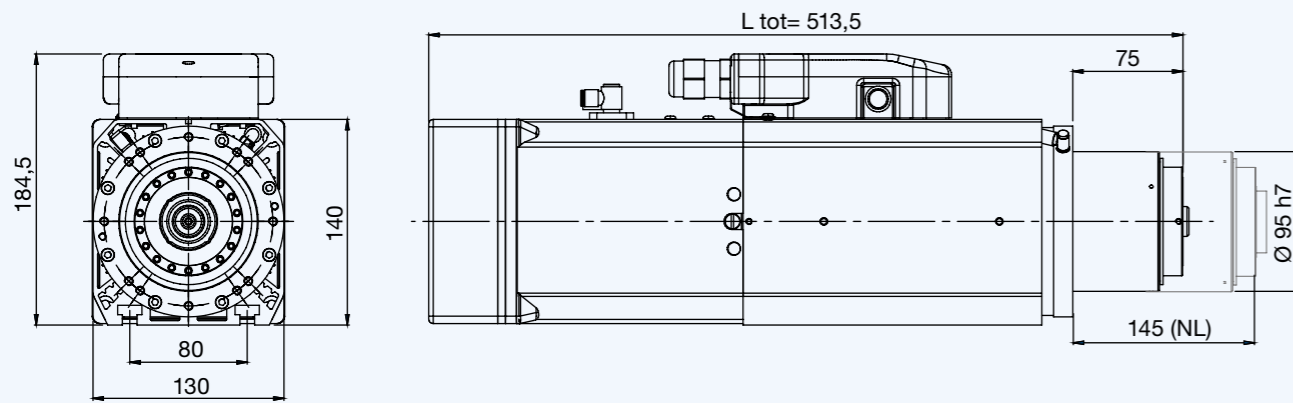

ALTRI LAYOUT / OTHER LAYOUTS

	ΔL	L tot
ISO 30	+6,9 mm	520,6 mm
Aria compressa / Compressed air	ISO30= -44 mm	469,5 mm
	HSK63F= -44 mm	469,5 mm
Encoder (1 Vpp or TTL)	+7 mm	520,5 mm
	+7 mm	470,5 mm

QE-1F 5.5/6 20

HIGH TORQUE

PRESTAZIONI / PERFORMANCES

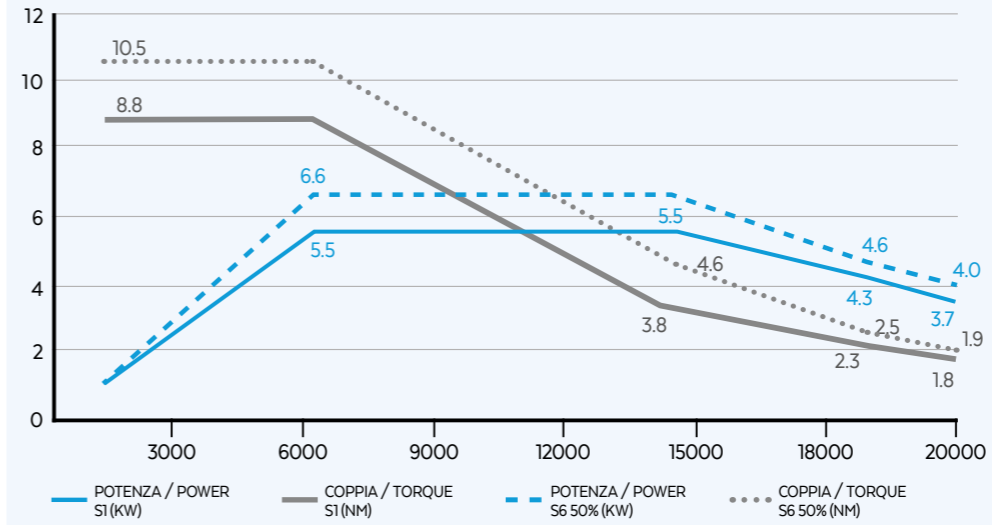

OPZIONALI / OPTIONS

- Encoder TVpp or TTL
- Circular connector CC
- Quick connection PP
- Air tool
- Long nose
- ISO 30
- Anti-rotation sleeves
- Bearings temperature monitoring
- Speed monitoring
- Vibration sensor
- C-AXES available
- iSPINDLE
- Compressed air cooling

SPECIFICHE TECNICHE / TECHNICAL SPECIFICATIONS

- S1-S6 kW 5.5/6.6
- S1-S6 Nm 8.8/10.5
- rpm 20000
- S1-S6 A 12/13
- Volt 380
- kg 24
- Pol es 4
- Supply inverter

EQUIPAGGIAMENTO / EQUIPMENT

- HSK 63F
- Ceramic ball bearings
- Taper cleaning
- Electrofan cooling
- Labyrinth with air seal
- Double effect pneumatic cylinder
- Sensors s1, s2, s3, s5
- Automatic tool change (A.T.C)
- Grease lubrication

QE-1F 7.5/6 24

HIGH TORQUE

PRESTAZIONI / PERFORMANCES

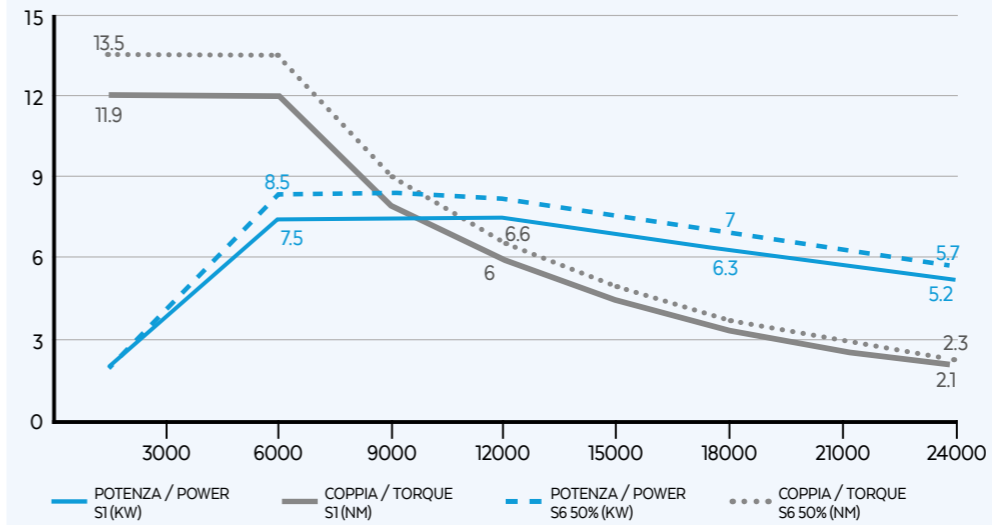

OPZIONALI / OPTIONS

- Encoder TVpp or TTL
- Circular connector CC
- Quick connection PP
- Air tool
- Long nose
- ISO 30
- Anti-rotation sleeves
- Bearings temperature monitoring
- Speed monitoring
- Vibration sensor
- C-AXES available
- iSPINDLE
- Grease lubrication

SPECIFICHE TECNICHE / TECHNICAL SPECIFICATIONS

- S1-S6 kW 7.5/8.5
- S1-S6 Nm 11.9/13.5
- rpm 24000
- S1-S6 A 19.5/21.5
- Volt 380
- kg 24
- Pol es 4
- Supply inverter

EQUIPAGGIAMENTO / EQUIPMENT

- HSK 63F
- Ceramic ball bearings
- Taper cleaning
- Electrofan cooling
- Labyrinth with air seal
- Double effect pneumatic cylinder
- Sensors s1, s2, s3, s5
- Automatic tool change (A.T.C)
- Grease lubrication

QE-1F 8.5/6 24

HIGH TORQUE

PRESTAZIONI / PERFORMANCES

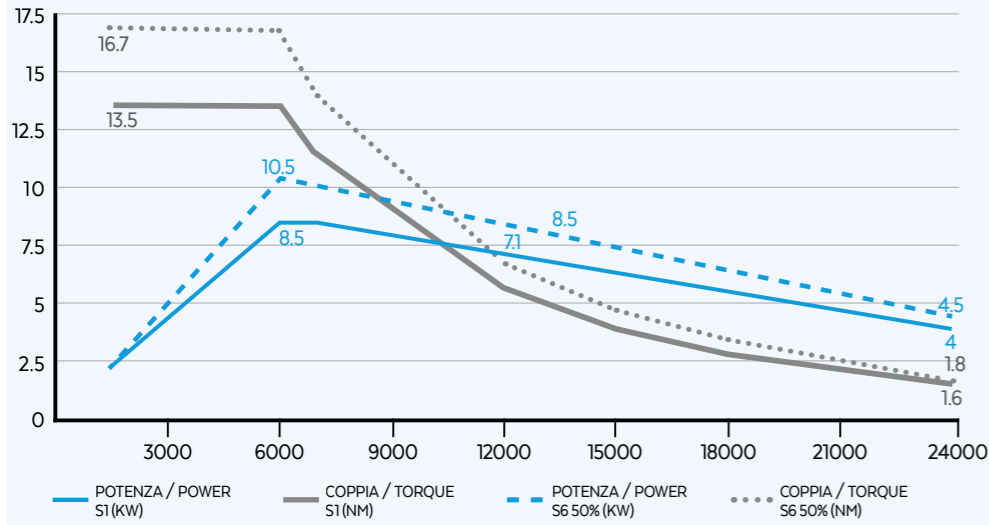

OPZIONALI / OPTIONS

- Encoder 1Vpp or TTL
- Circular connector CC
- Quick connection PP
- Long nose
- Air tool
- Anti-rotation sleeves
- Bearings temperature monitoring
- Speed monitoring
- Vibration sensor
- C-axes available
- ISO 30
- iSPINDLE

SPECIFICHE TECNICHE / TECHNICAL SPECIFICATIONS

- S1-S6 kW 8.5/10.5
- S1-S6 A 20/25
- Pol es 4
- S1-S6 Nm 13.5/16.7
- Volt 380
- Supply inverter
- rpm 24000
- kg 24

EQUIPAGGIAMENTO / EQUIPMENT

- HSK 63F
- Electrofan cooling
- Double effect pneumatic cylinder
- Automatic tool change (A.T.C)
- Ceramic ball bearings
- Labyrinth with air seal
- Sensors s1, s2, s3, s5
- Grease lubrication
- Taper cleaning

QE-1F 8.5/12 24

PRESTAZIONI / PERFORMANCES

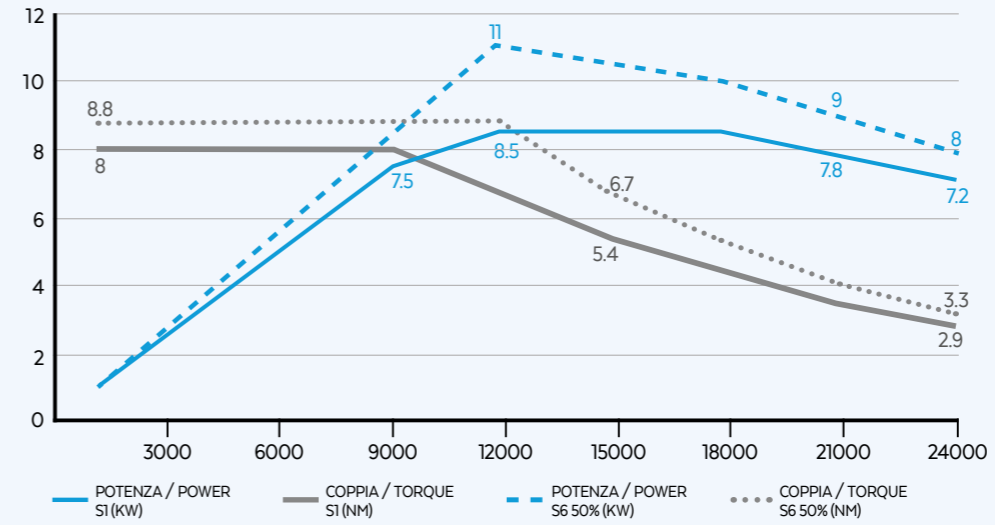

OPZIONALI / OPTIONS

- Encoder 1Vpp or TTL
- Circular connector CC
- Quick connection PP
- Long nose
- Air tool
- Voltage 220V
- Dual voltage 220V-380V
- Anti-rotation sleeves
- Bearings temperature monitoring
- Speed monitoring
- Vibration sensor
- C-axes available
- Compressed air cooling
- ISO 30
- iSPINDLE

SPECIFICHE TECNICHE / TECHNICAL SPECIFICATIONS

- S1-S6 kW 8/9.5
- S1-S6 A 22/23
- Pol es 4
- S1-S6 Nm 6.4/7.6
- Volt 380
- Supply inverter
- rpm 24000
- kg 21

EQUIPAGGIAMENTO / EQUIPMENT

- HSK 63F
- Electrofan cooling
- Double effect pneumatic cylinder
- Automatic tool change (A.T.C)
- Ceramic ball bearings
- Labyrinth with air seal
- Sensors s1, s2, s3, s5
- Grease lubrication
- Taper cleaning

QE-1F 10/11 24

PRESTAZIONI / PERFORMANCES

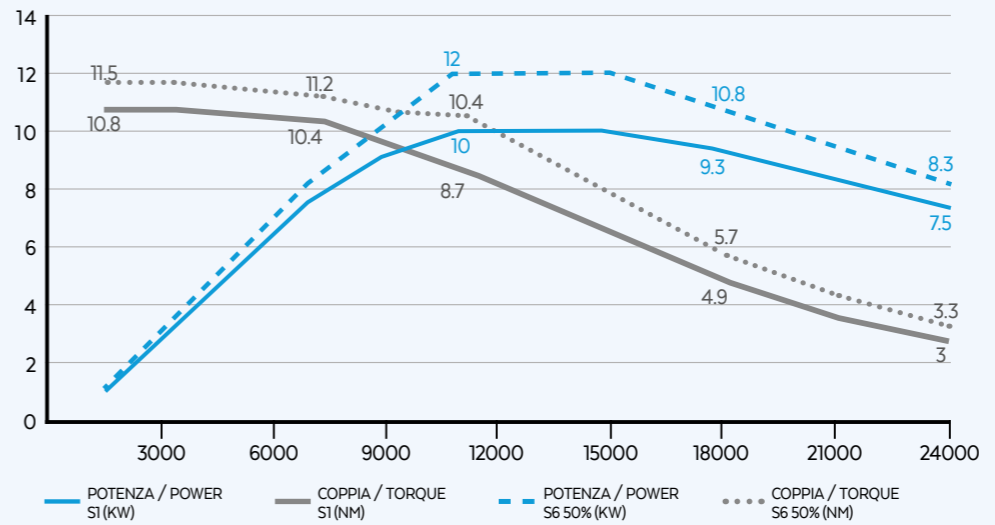

OPZIONALI / OPTIONS

- Encoder 1Vpp or TTL
- Circular connector CC
- Quick connection PP
- ISO 30
- Voltage 220V
- Dual voltage 220V-380V
- Anti-rotation sleeves
- Bearings temperature monitoring
- Speed monitoring
- Vibration sensor
- C-axes available
- Long nose
- iSPINDLE
- Compressed air cooling

SPECIFICHE TECNICHE / TECHNICAL SPECIFICATIONS

- S1-S6 kW 10/12
- S1-S6 A 25/27
- Pol es 4
- S1-S6 Nm 10.8/11.5
- Volt 380
- Supply inverter
- rpm 24000
- kg 23

EQUIPAGGIAMENTO / EQUIPMENT

- HSK 63F
- Electrofan cooling
- Double effect pneumatic cylinder
- Automatic tool change (A.T.C)
- Ceramic ball bearings
- Labyrinth with air seal
- Sensors s1, s2, s3, s5
- Grease lubrication
- Taper cleaning



QE-1F 12/12 24

PRESTAZIONI / PERFORMANCES

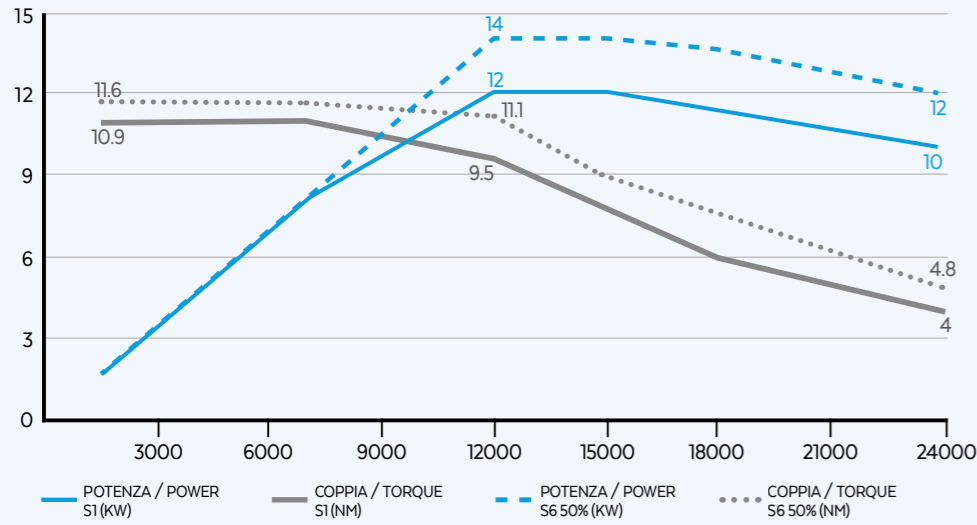

OPZIONALI / OPTIONS

- Encoder TVpp or TTL
- Circular connector CC
- Quick connection pp
- Air tool
- Long nose
- Anti-rotation sleeves
- Bearings temperature monitoring
- Speed monitoring
- Vibration sensor
- C-axes available
- iSPINDLE

SPECIFICHE TECNICHE / TECHNICAL SPECIFICATIONS

- S1-S6 kW** 12/14
- S1-S6 A** 23/27
- Pol es** 4
- S1-S6 Nm** 10.9/11.6
- Volt** 380
- Supply** inverter
- rpm** 24000
- kg** 23

EQUIPAGGIAMENTO / EQUIPMENT

- HSK 63F
- Electrofan cooling
- Double effect pneumatic cylinder
- Automatic tool change (A.T.C)
- Ceramic ball bearings
- Sensors s1, s2, s3, s5
- Grease lubrication
- Taper cleaning
- Labyrinth with air seal

LAYOUT HSK 63F CB

LIQUID

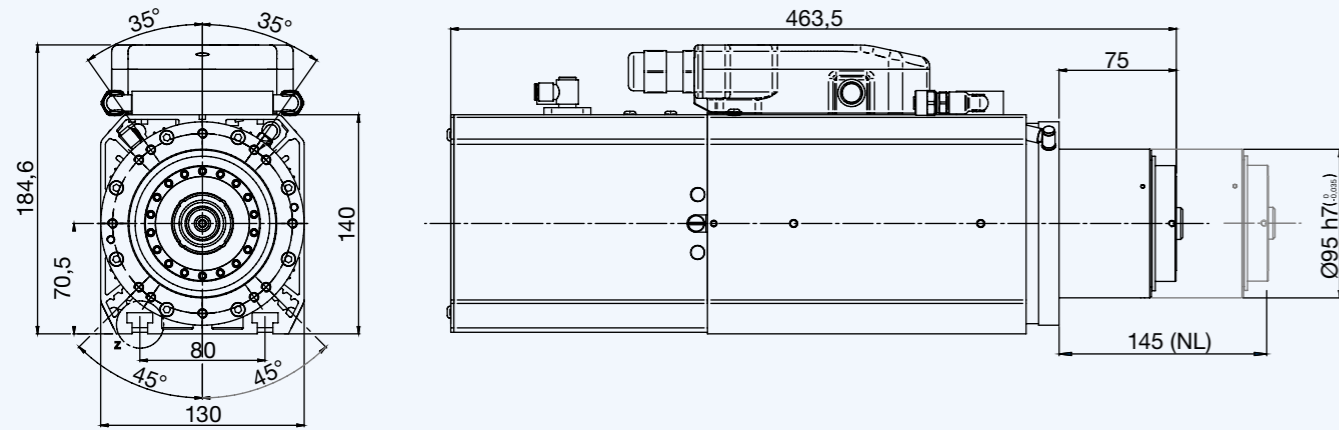

ALTRI LAYOUT / OTHER LAYOUTS

	ΔL	L tot
Encoder (1 Vpp or TTL)	+7 mm	470,5 mm
ISO 30	+7 mm	470,5 mm

QE-2 9/6 24

LIQUID HIGH TORQUE

PRESTAZIONI / PERFORMANCES

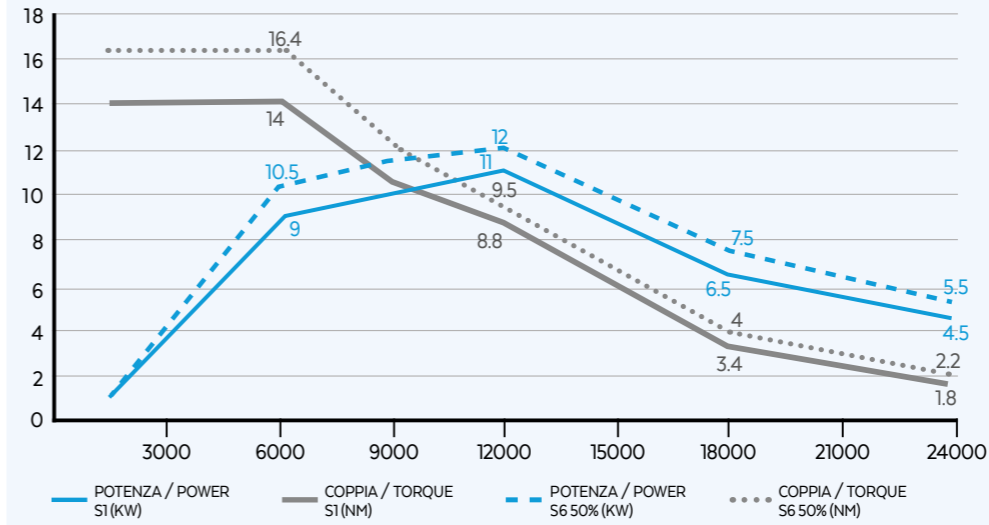

OPZIONALI / OPTIONS

- Encoder TVpp or TTL
- Circular connector CC
- Quick connection pp
- Air tool
- Long nose
- iSPINDLE
- Bearings temperature monitoring
- Speed monitoring
- Vibration sensor
- C-axes available
- Anti-rotation sleeves

SPECIFICHE TECNICHE / TECHNICAL SPECIFICATIONS

- S1-S6 kW** 9/10.5
- S1-S6 A** 20/22.5
- Pol es** 4
- S1-S6 Nm** 14/16.4
- Volt** 380
- Supply** inverter
- rpm** 24000
- kg** 23

EQUIPAGGIAMENTO / EQUIPMENT

- HSK 63F
- Liquid cooling
- Double effect pneumatic cylinder
- Automatic tool change (A.T.C)
- Ceramic ball bearings
- Labyrinth with air seal
- Sensors s1, s2, s3, s5
- Grease lubrication
- Taper cleaning

QE-2 11/6 24

LIQUID HIGH TORQUE

PRESTAZIONI / PERFORMANCES

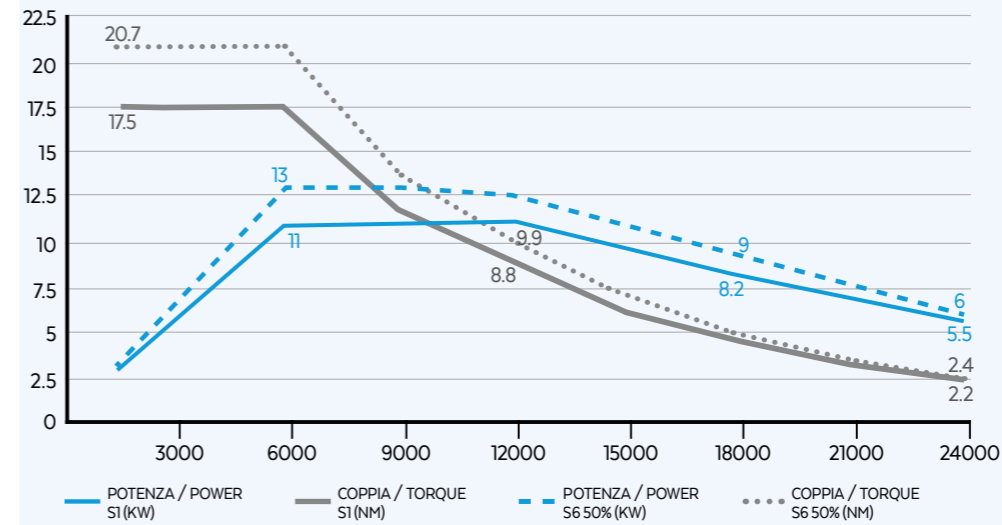

OPZIONALI / OPTIONS

- Encoder TVpp or TTL
- Circular connector CC
- Quick connection pp
- Air tool
- Long nose
- Anti-rotation sleeves
- Bearings temperature monitoring
- Speed monitoring
- Vibration sensor
- C-axes available
- iSPINDLE

SPECIFICHE TECNICHE / TECHNICAL SPECIFICATIONS

- S1-S6 kW** 11/13
- S1-S6 A** 24/28
- Pol es** 4
- S1-S6 Nm** 17.5/20.7
- Volt** 380
- Supply** inverter
- rpm** 24000
- kg** 23

EQUIPAGGIAMENTO / EQUIPMENT

- HSK 63F
- Liquid cooling
- Double effect pneumatic cylinder
- Automatic tool change (A.T.C)
- Ceramic ball bearings
- Labyrinth with air seal
- Sensors s1, s2, s3, s5
- Grease lubrication
- Taper cleaning

QE-2 13/12 24

LIQUID

PRESTAZIONI / PERFORMANCES

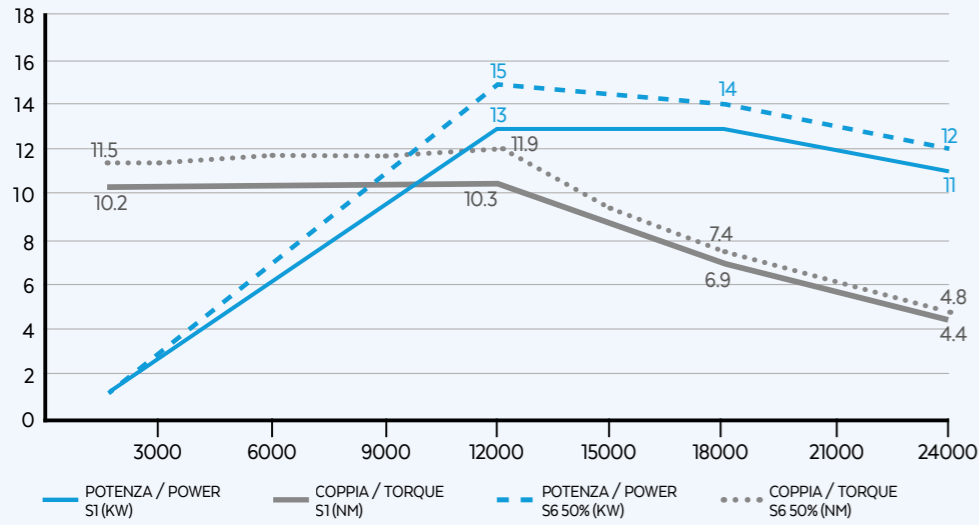

OPZIONALI / OPTIONS

- Encoder 1 Vpp or TTL
- Circular connector CC
- Quick connection PP
- Air tool
- Long nose
- iSPINDLE
- Bearings temperature monitoring
- Speed monitoring
- Vibration sensor
- C-axes available
- Anti-rotation sleeves

SPECIFICHE TECNICHE / TECHNICAL SPECIFICATIONS

- 13/15
- 28/31
- 4
- 10.3/11.9
- 380
- inverter
- 24000
- 23

EQUIPAGGIAMENTO / EQUIPMENT

- HSK 63F
- Liquid cooling
- Ceramic ball bearings
- Labyrinth with air seal
- Taper cleaning
- Double effect pneumatic cylinder
- Sensors s1, s2, s3, s5
- Automatic tool change (A.T.C)
- Grease lubrication

QE-2 16/12 24

LIQUID

PRESTAZIONI / PERFORMANCES

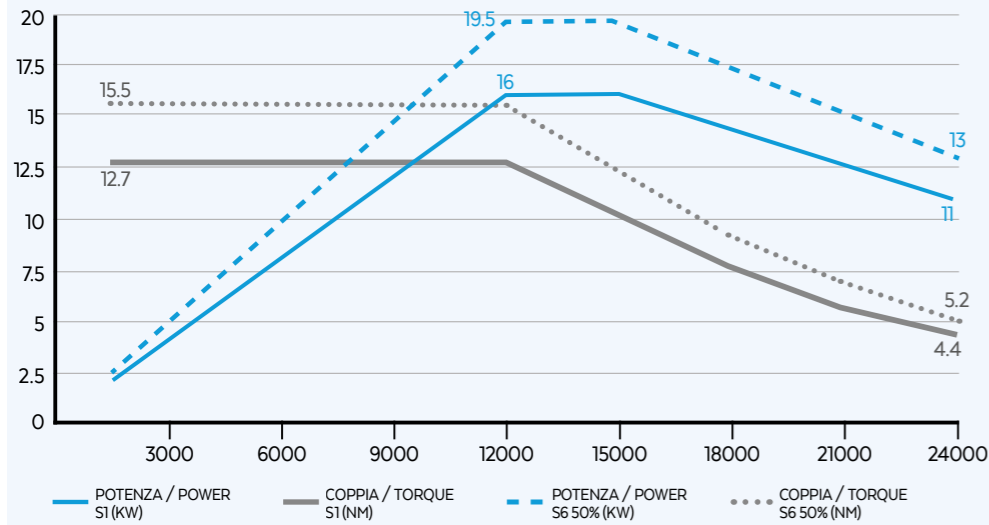

OPZIONALI / OPTIONS

- Encoder 1 Vpp or TTL
- Quick connection PP
- Air tool
- Long nose
- iSPINDLE
- Bearings temperature monitoring
- Speed monitoring
- Vibration sensor
- C-axes available
- Automatic tool change (A.T.C)
- Grease lubrication

SPECIFICHE TECNICHE / TECHNICAL SPECIFICATIONS

- 16/19.5
- 31/36
- 4
- 12.7/15.5
- 380
- inverter
- 24000
- 23

EQUIPAGGIAMENTO / EQUIPMENT

- HSK 63F
- Liquid cooling
- Ceramic ball bearings
- Labyrinth with air seal
- Taper cleaning
- Double effect pneumatic cylinder
- Sensors s1, s2, s3, s5
- Automatic tool change (A.T.C)
- Grease lubrication



POWERTECH 500



SUITABLE FOR MACHINING WOOD AND ALUMINUM
 WIDE RANGE OF POWER UP TO 18 KW AND HIGH TORQUES FOR HEAVY MACHINING
 HSK 63E VERSIONS FOR WORKING WITH DOUBLE PROFILE TOOLS
 SUITABLE FOR MACHINING WOODEN WINDOWS AND DOORS
 AVAILABLE WITH LIQUID COOLING FOR INTENSIVE PROCESSES

LAYOUT HSK 63F PP

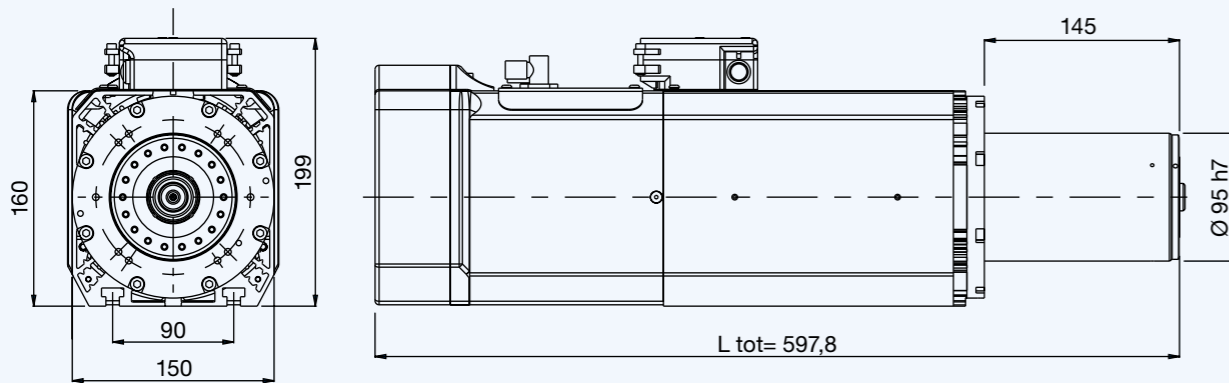

QF-1F 8/9 18

HIGH TORQUE

PRESTAZIONI / PERFORMANCES

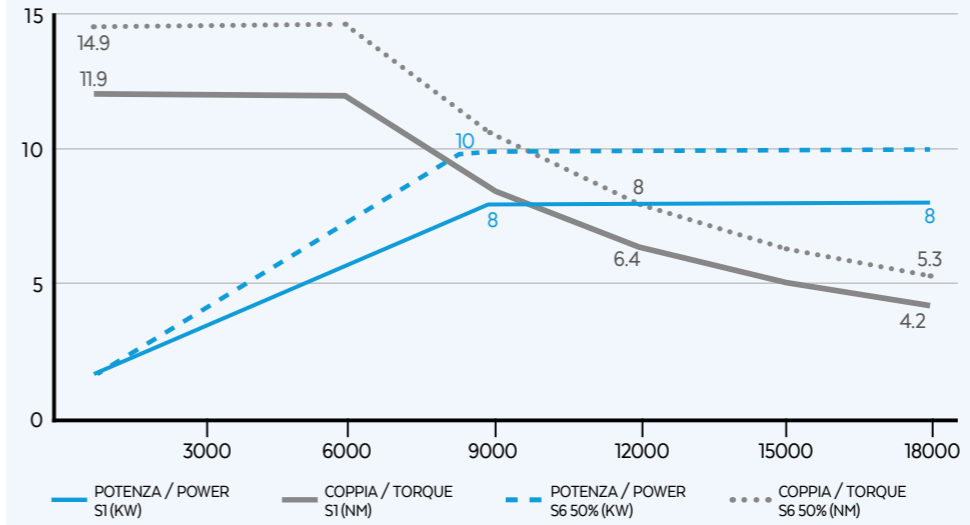

OPZIONALI / OPTIONS

- Bearings temperature monitoring
- Vibration sensor
- Speed monitoring
- Plug & Play Quick connection pp machine side
- HSK 63E

SPECIFICHE TECNICHE / TECHNICAL SPECIFICATIONS

- S1-S6 kW 8/10
- S1-S6 Nm 11.9/14.6
- rpm 18000
- S1-S6 A 20/24
- Volt 380
- kg 35
- Pol es 4
- Supply inverter

EQUIPAGGIAMENTO / EQUIPMENT

- HSK 63F
- Ceramic ball bearings
- Taper cleaning
- Electrofan cooling
- Labyrinth with air seal
- Quick connection PP spindle side
- Double effect pneumatic cylinder
- Sensors s1, s2, s3
- Automatic tool change (A.T.C)
- Grease lubrication

QF-1F 13/7 18

HIGH TORQUE

PRESTAZIONI / PERFORMANCES

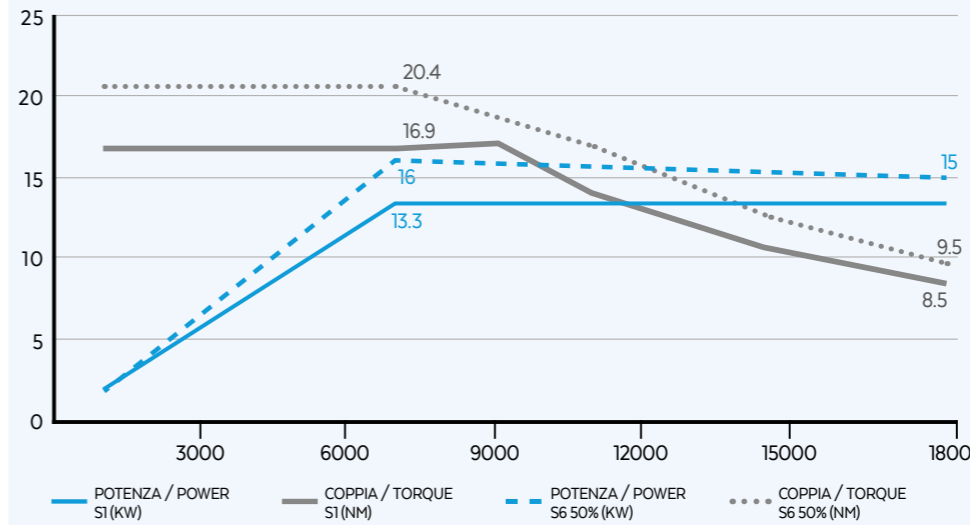

OPZIONALI / OPTIONS

- Bearings temperature monitoring
- Vibration sensor
- Speed monitoring
- Plug & Play Quick connection pp machine side
- Temperature sensor
- HSK 63E

SPECIFICHE TECNICHE / TECHNICAL SPECIFICATIONS

- S1-S6 kW 13.3/16
- S1-S6 Nm 16.9/20.4
- rpm 18000
- S1-S6 A 28/32
- Volt 380
- kg 35
- Pol es 4
- Supply inverter

EQUIPAGGIAMENTO / EQUIPMENT

- HSK 63F
- Ceramic ball bearings
- Taper cleaning
- Electrofan cooling
- Labyrinth with air seal
- Quick connection PP spindle side
- Double effect pneumatic cylinder
- Sensors s1, s2, s3
- Automatic tool change (A.T.C)
- Grease lubrication

QF-1F 11/12 20

PRESTAZIONI / PERFORMANCES

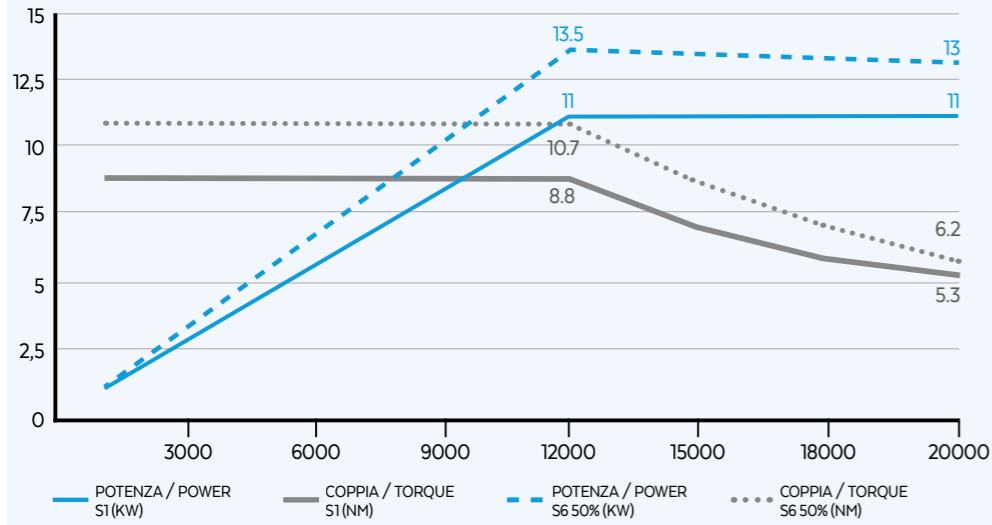

OPZIONALI / OPTIONS

- Bearings temperature monitoring
- Vibration sensor
- Speed monitoring
- Quick connection pp machine side

SPECIFICHE TECNICHE / TECHNICAL SPECIFICATIONS

- S1-S6 kW** 11/13.5
- S1-S6 A** 28/32
- Pol es** 4
- S1-S6 Nm** 8.8/10.7
- Volt** 380
- Supply** inverter
- rpm** 20000
- kg** 35

EQUIPAGGIAMENTO / EQUIPMENT

- HSK 63F
- Electrofan cooling
- Double effect pneumatic cylinder
- Automatic tool change (A.T.C)
- Ceramic ball bearings
- Labyrinth with air seal
- Sensors s1, s2, s3
- Grease lubrication
- Taper cleaning
- Quick connection PP spindle side

LAYOUT HSK 63F PP

LIQUID

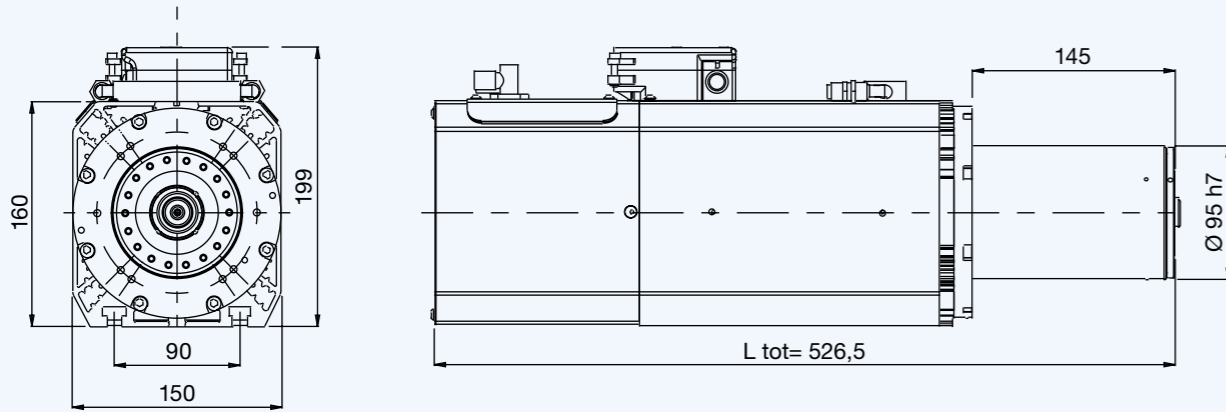

ALTRI LAYOUT / OTHER LAYOUTS

	ΔL	L tot
HSK 63E	+21 mm	547,5 mm

QF-2 12/6 18

LIQUID HIGH TORQUE

PRESTAZIONI / PERFORMANCES

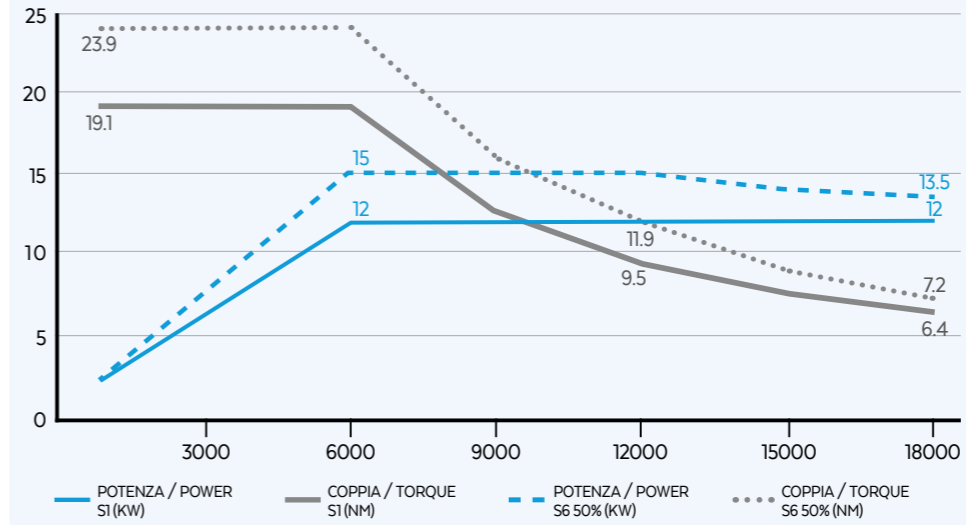

OPZIONALI / OPTIONS

- Bearings temperature monitoring
- Vibration sensor
- Speed monitoring
- Quick connection pp machine side
- HSK 63E

SPECIFICHE TECNICHE / TECHNICAL SPECIFICATIONS

- S1-S6 kW** 12/15
- S1-S6 A** 28/35
- Pol es** 4
- S1-S6 Nm** 19.1/23.9
- Volt** 380
- Supply** inverter
- rpm** 18000
- kg** 35

EQUIPAGGIAMENTO / EQUIPMENT

- HSK 63F
- Liquid cooling
- Double effect pneumatic cylinder
- Automatic tool change (A.T.C)
- Ceramic ball bearings
- Labyrinth with air seal
- Sensors s1, s2, s3
- Grease lubrication
- Taper cleaning
- Quick connection PP spindle side

QF-2 18/12 20

LIQUID

PRESTAZIONI / PERFORMANCES

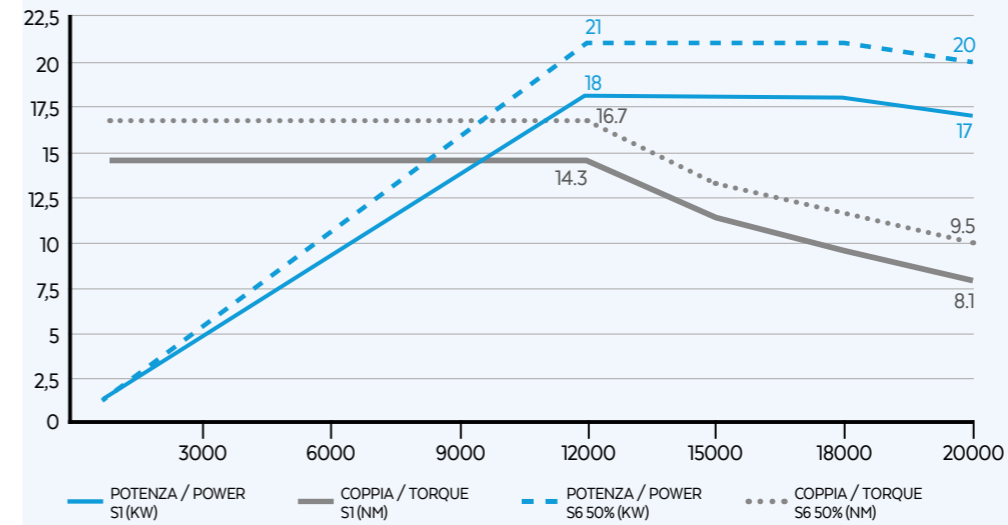

OPZIONALI / OPTIONS

- Bearings temperature monitoring
- Vibration sensor
- Speed monitoring
- Quick connection pp machine side
- HSK 63E

SPECIFICHE TECNICHE / TECHNICAL SPECIFICATIONS

- S1-S6 kW** 18/21
- S1-S6 A** 36/41
- Pol es** 4
- S1-S6 Nm** 14.3/16.7
- Volt** 380
- Supply** inverter
- rpm** 20000
- kg** 35

EQUIPAGGIAMENTO / EQUIPMENT

- HSK 63F
- Liquid cooling
- Double effect pneumatic cylinder
- Automatic tool change (A.T.C)
- Ceramic ball bearings
- Labyrinth with air seal
- Sensors s1, s2, s3
- Grease lubrication
- Taper cleaning
- Quick connection PP spindle side

POWERTECH 600



SUITABLE FOR MACHINING WOOD AND ALUMINUM
POWER UP TO 18 KW AND HIGH TORQUES FOR HEAVY MACHINING
AIR COOLING
SUITABLE FOR HEAVY MACHINING ON WOODEN WINDOWS AND DOORS

LAYOUT HSK 80F PP

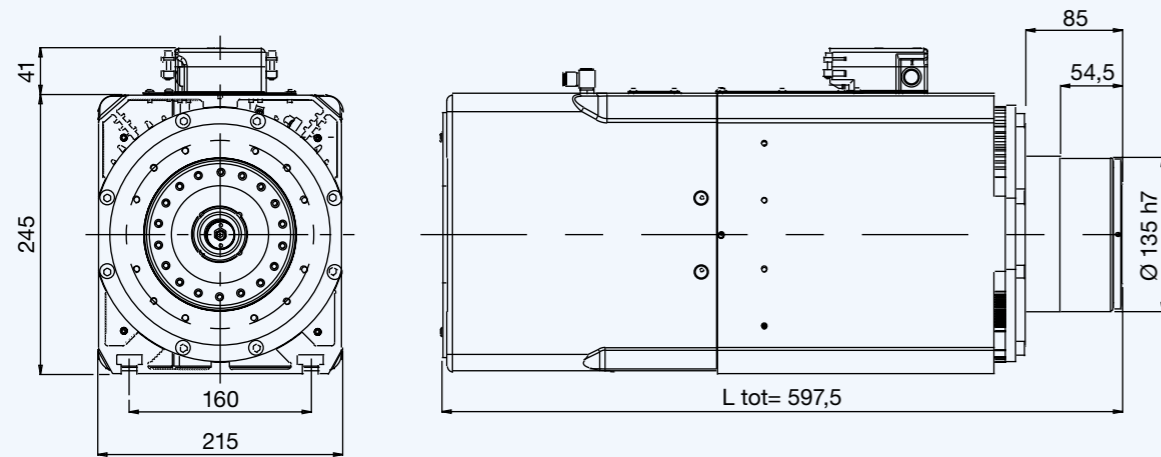

QM-1F 11/6 10

HIGH TORQUE

PRESTAZIONI / PERFORMANCES

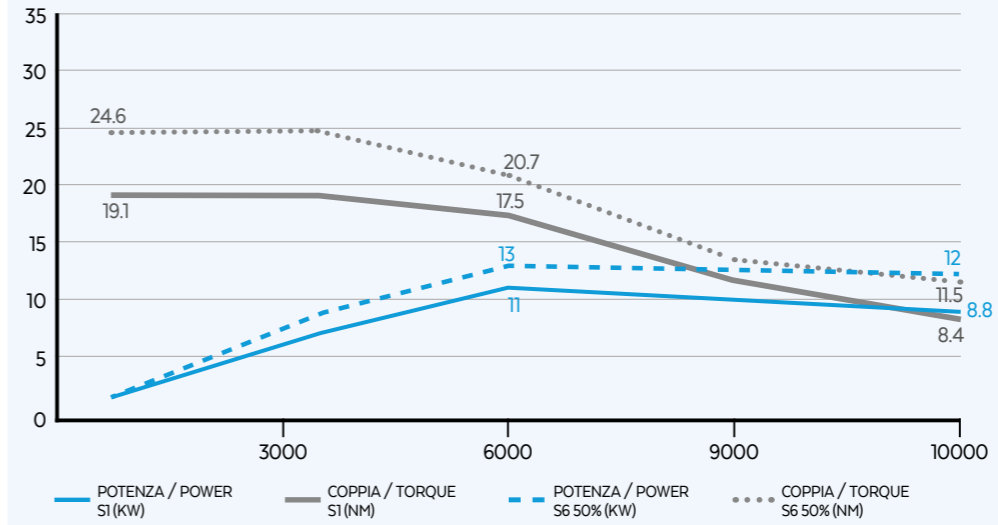

OPZIONALI / OPTIONS

- IM Bearings temperature monitoring
- IM² Speed monitoring
- IM Vibration sensor
- Plug & Play Quick connection pp machine side
- HSK 85S
- iS iSPINDLE

SPECIFICHE TECNICHE / TECHNICAL SPECIFICATIONS

- S1-S6 kW 11/13
- S1-S6 A 25/33
- Pol es 4
- S1-S6 Nm 19.1/24.6
- Volt 380
- Supply inverter
- rpm 10000
- kg 70

EQUIPAGGIAMENTO / EQUIPMENT

- HSK 80F
- Electrofan cooling
- Single effect pneumatic cylinder
- Automatic tool change (A.T.C)
- Ceramic ball bearings
- Labyrinth with air seal
- Sensors s1, s2, s3
- Grease lubrication
- Plug & Play Quick connection PP spindle side
- Taper cleaning

QM-1F 18/6 12

HIGH TORQUE

PRESTAZIONI / PERFORMANCES

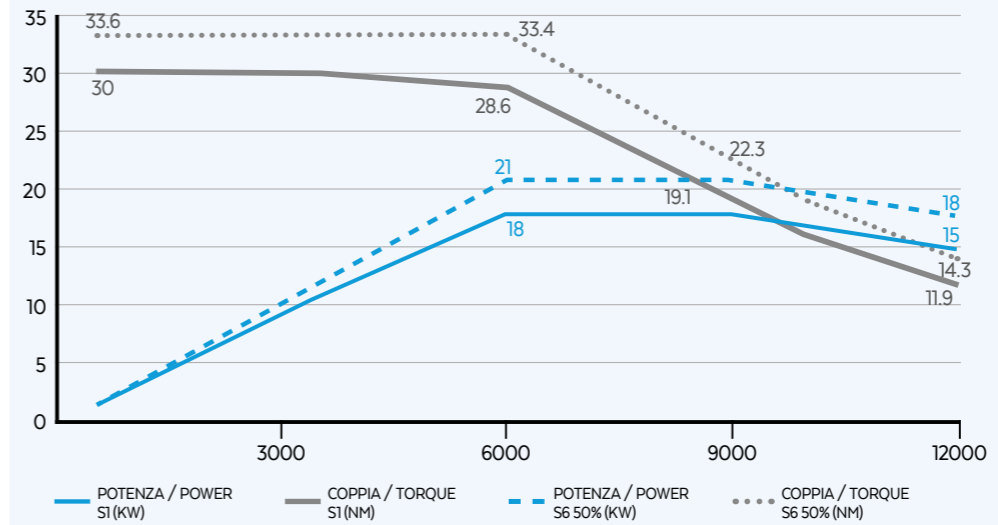

OPZIONALI / OPTIONS

- IM Bearings temperature monitoring
- IM² Speed monitoring
- IM Vibration sensor
- Plug & Play Quick connection pp machine side
- HSK 85S
- iS iSPINDLE

SPECIFICHE TECNICHE / TECHNICAL SPECIFICATIONS

- S1-S6 kW 18/21
- S1-S6 A 37/42
- Pol es 4
- S1-S6 Nm 30/33.6
- Volt 380
- Supply inverter
- rpm 12000
- kg 70

EQUIPAGGIAMENTO / EQUIPMENT

- HSK 80F
- Electrofan cooling
- Single effect pneumatic cylinder
- Automatic tool change (A.T.C)
- Ceramic ball bearings
- Labyrinth with air seal
- Sensors s1, s2, s3
- Grease lubrication
- Plug & Play Quick connection PP spindle side
- Taper cleaning



SUITABLE FOR MACHINING WOOD AND ALUMINUM
HIGH POWER IN A VERY COMPACT BODY
SUITABLE FOR BI-ROTARY HEADS (50° AND 90°) AND ROBOT APPLICATIONS
AVAILABLE WITH ENCODER ON BOARD

LAYOUT HSK 63F

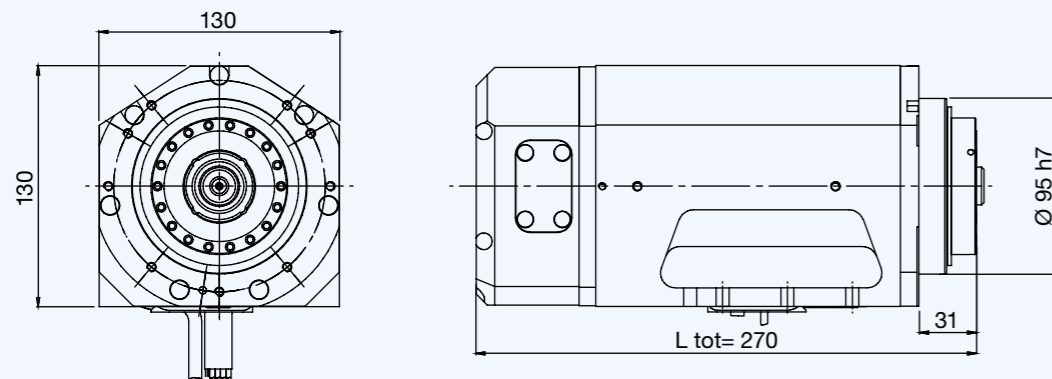

ALTRI LAYOUT / OTHER LAYOUTS

	ΔL	L tot
Encoder (1 Vpp or TTL)	+25 mm	295 mm

QX-2 8.5/12 24

PRESTAZIONI / PERFORMANCES

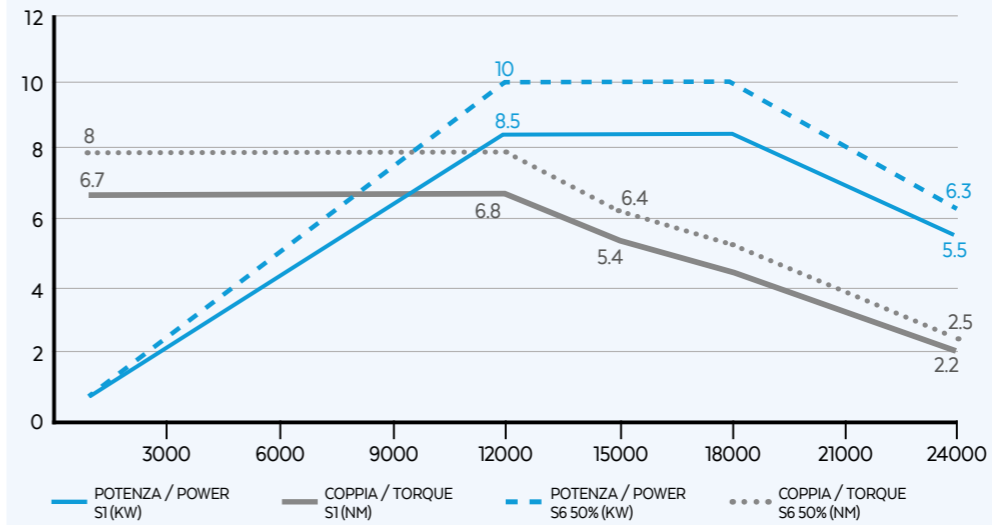

OPZIONALI / OPTIONS

- Encoder 1Vpp or TTL
- Bearings temperature monitoring
- Voltage 220V
- Speed monitoring
- Vibration sensor

SPECIFICHE TECNICHE / TECHNICAL SPECIFICATIONS

- Power: 8.5/10 kW
- Current: 20/22 A
- Pol: 4
- Voltage: 380 Volt
- Supply: inverter
- Speed: 24000 rpm
- Weight: 18 kg

EQUIPAGGIAMENTO / EQUIPMENT

- HSK 63F
- Liquid cooling
- Single effect pneumatic cylinder
- Automatic tool change (A.T.C)
- Ceramic ball bearings
- Labyrinth with air seal
- Sensors s1, s2, s3, s5
- Grease lubrication
- Taper cleaning

QX-2 10/12 24

PRESTAZIONI / PERFORMANCES

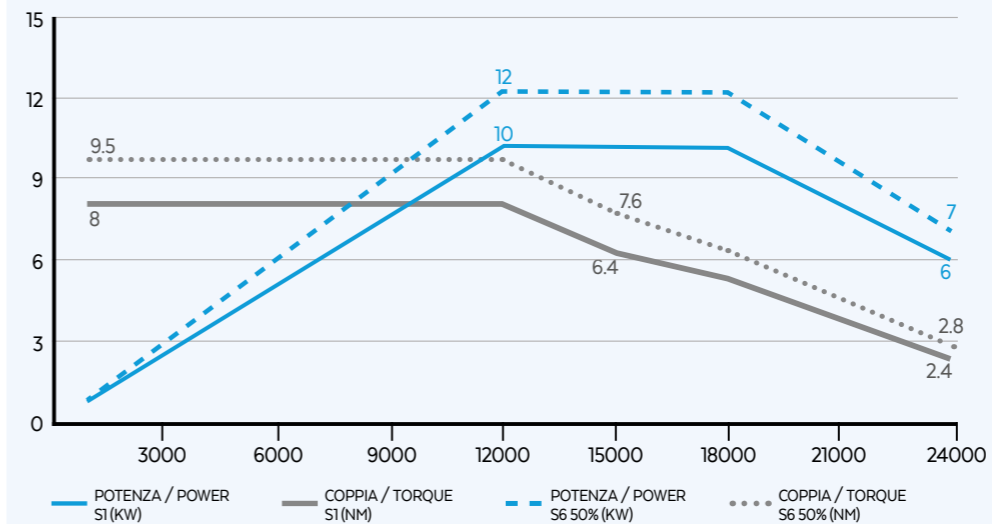

OPZIONALI / OPTIONS

- Encoder 1Vpp or TTL
- Bearings temperature monitoring
- Voltage 220V
- Speed monitoring
- Vibration sensor

SPECIFICHE TECNICHE / TECHNICAL SPECIFICATIONS

- Power: 10/12 kW
- Current: 23/26 A
- Pol: 4
- Voltage: 380 Volt
- Supply: inverter
- Speed: 24000 rpm
- Weight: 19 kg

EQUIPAGGIAMENTO / EQUIPMENT

- HSK 63F
- Liquid cooling
- Single effect pneumatic cylinder
- Automatic tool change (A.T.C)
- Ceramic ball bearings
- Labyrinth with air seal
- Sensors s1, s2, s3, s5
- Grease lubrication
- Taper cleaning

QX-2 11/12 24

LIQUID

PRESTAZIONI / PERFORMANCES

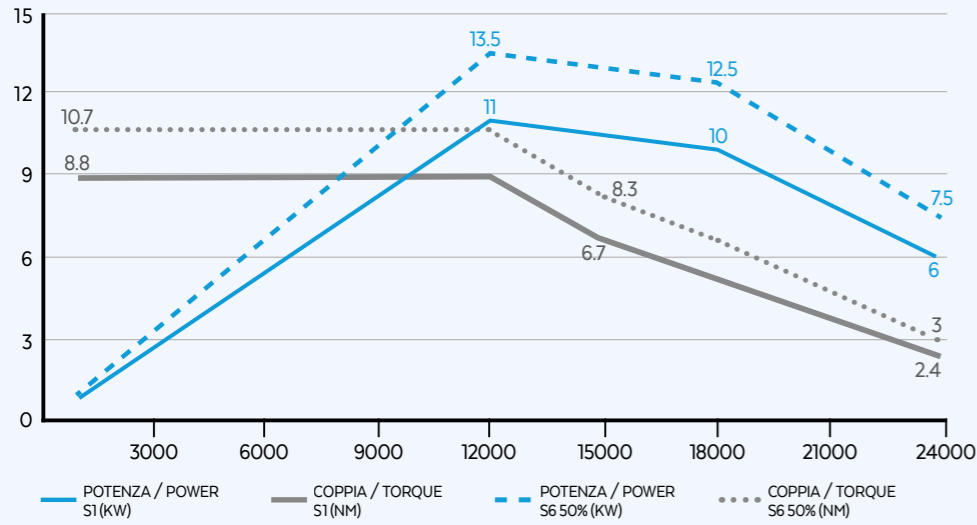

OPZIONALI / OPTIONS

- Encoder 1Vpp or TTL
- Bearings temperature monitoring
- Vibration sensor
- Speed monitoring

SPECIFICHE TECNICHE / TECHNICAL SPECIFICATIONS

- S1-S6 kW** 11/13.5
- S1-S6 A** 24.5/29.5
- Pol es** 4
- S1-S6 Nm** 8.8/10.7
- Volt** 380
- Supply** inverter
- rpm** 24000
- kg** 19

EQUIPAGGIAMENTO / EQUIPMENT

- HSK 63F
- Liquid cooling
- Single effect pneumatic cylinder
- Automatic tool change (A.T.C)
- Ceramic ball bearings
- Labyrinth with air seal
- Sensors s1, s2, s3, s5
- Grease lubrication
- Taper cleaning

QX-1C 5/12 21

COMPRESSED AIR

PRESTAZIONI / PERFORMANCES

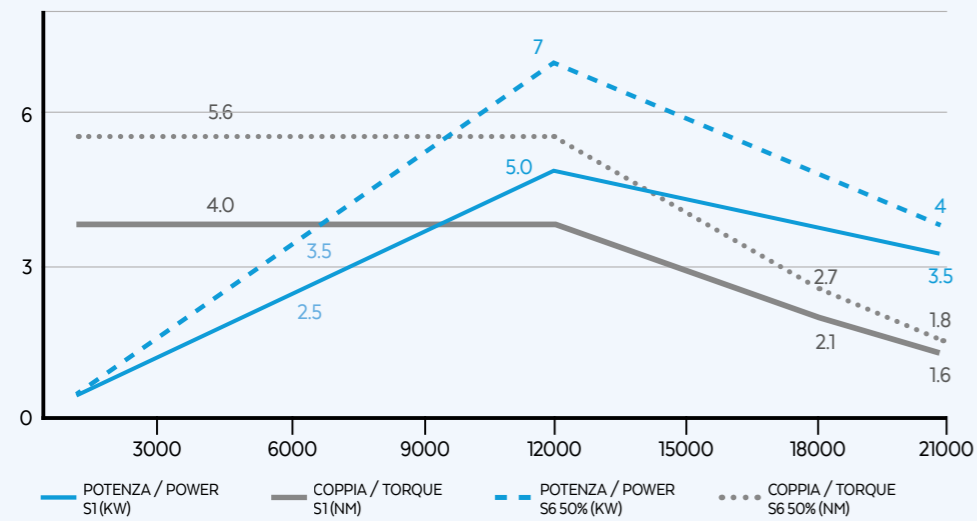

OPZIONALI / OPTIONS

- Encoder 1Vpp or TTL
- Bearings temperature monitoring
- Vibration sensor
- Speed monitoring

SPECIFICHE TECNICHE / TECHNICAL SPECIFICATIONS

- S1-S6 kW** 5/7
- S1-S6 A** 23/26
- Pol es** 4
- S1-S6 Nm** 4/5.6
- Volt** 380
- Supply** inverter
- rpm** 21000
- kg** 18

EQUIPAGGIAMENTO / EQUIPMENT

- HSK 63F
- Compressed air cooling
- Single effect pneumatic cylinder
- Automatic tool change (A.T.C)
- Ceramic ball bearings
- Labyrinth with air seal
- Sensors s1, s2, s3, s5
- Grease lubrication
- Taper cleaning

QX-2 11/10 24 63F NC

HIGH TORQUE

PRESTAZIONI / PERFORMANCES

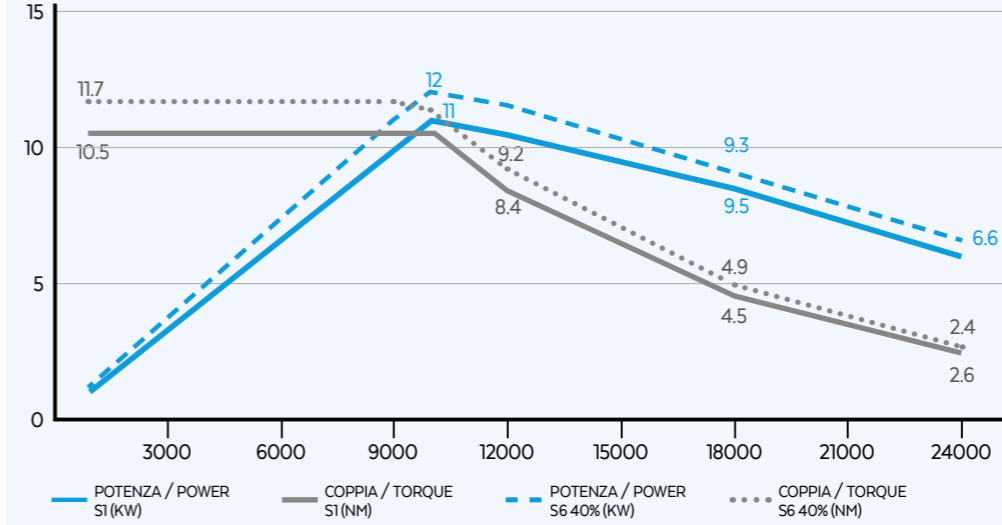

OPZIONALI / OPTIONS

- Encoder 1Vpp or TTL
- Bearings temperature monitoring
- Speed monitoring
- Vibration sensor
- Anti-rotation sleeves



SPECIFICHE TECNICHE / TECHNICAL SPECIFICATIONS

- S1-S6 kW** 11/12
- S1-S6 A** 29/31
- Pol es** 6
- S1-S6 Nm** 10,5/11,7
- Volt** 380
- Supply** inverter
- rpm** 24000
- kg** 21

EQUIPAGGIAMENTO / EQUIPMENT

- HSK 63F
- Liquid cooling
- Single effect pneumatic cylinder
- Automatic tool change (A.T.C)
- Ceramic ball bearings
- Labyrinth with air seal
- Sensors s1, s2, s3, s5
- Grease lubrication
- Taper cleaning

ROBOTECH QX HIGH SPEED



SUITABLE FOR MACHINING PLASTICS, ALUMINUM AND COMPOSITES
HIGH SPEED UP TO 40K RPM
SUITABLE FOR BI-ROTARY HEADS (50° AND 90°) AND ROBOT APPLICATIONS
AVAILABLE WITH ENCODER ON BOARD

LAYOUT HSK 32E / HSK 40E

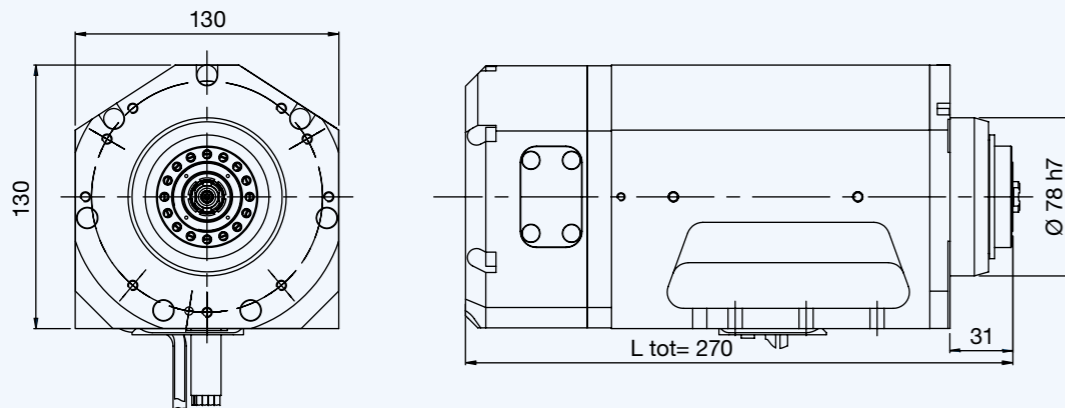

HIGH SPEED

QX-2 8/15 36

PRESTAZIONI / PERFORMANCES

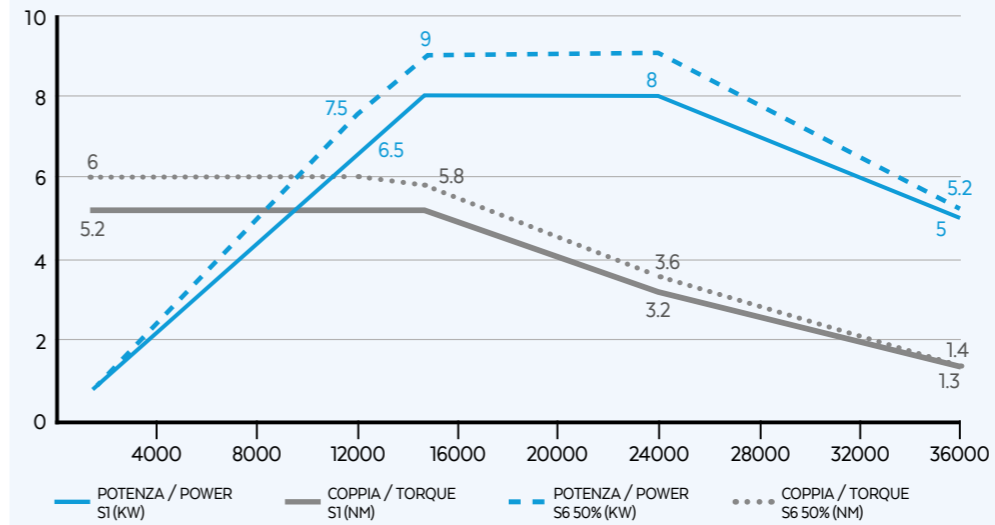

OPZIONALI / OPTIONS

- Encoder TVpp or TTL
- Bearings temperature monitoring
- Speed monitoring
- Vibration sensor
- Anti-rotation sleeves

SPECIFICHE TECNICHE / TECHNICAL SPECIFICATIONS

- S1-S6 kW 8/9
- S1-S6 A 23/25
- Pol es 4
- S1-S6 Nm 5.2/6
- Volt 380
- Supply inverter
- rpm 36000
- kg 18

EQUIPAGGIAMENTO / EQUIPMENT

- HSK 40E
- Liquid cooling
- Single effect pneumatic cylinder
- Automatic tool change (A.T.C)
- Ceramic ball bearings
- Labyrinth with air seal
- Sensors s1, s2, s3, s5
- Grease lubrication
- Taper cleaning

QX-2 8/15 40

HIGH SPEED

PRESTAZIONI / PERFORMANCES

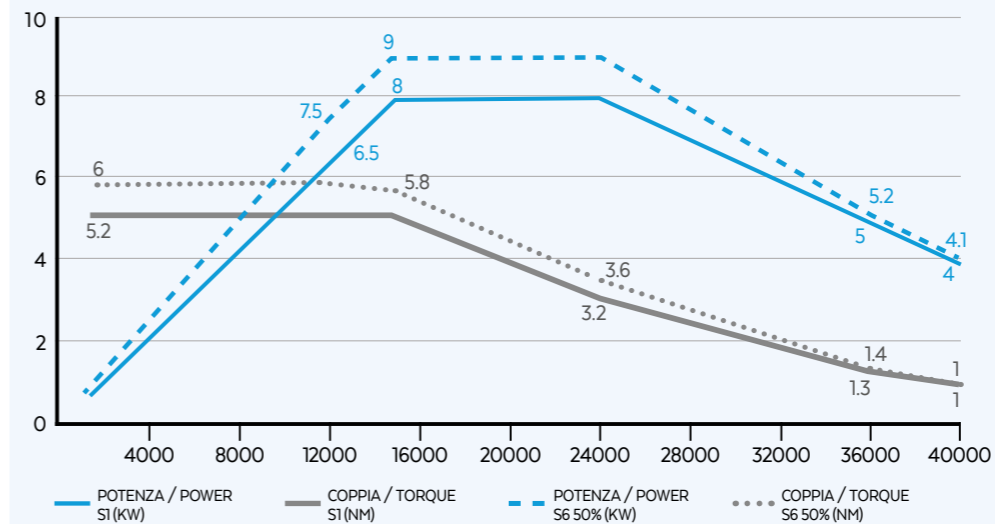

OPZIONALI / OPTIONS

- Encoder TVpp or TTL
- Bearings temperature monitoring
- Speed monitoring
- Vibration sensor
- Anti-rotation sleeves

SPECIFICHE TECNICHE / TECHNICAL SPECIFICATIONS

- S1-S6 kW 8/9
- S1-S6 A 23/25
- Pol es 4
- S1-S6 Nm 5.2/6
- Volt 380
- Supply inverter
- rpm 40000
- kg 18

EQUIPAGGIAMENTO / EQUIPMENT

- HSK 32E
- Liquid cooling
- Single effect pneumatic cylinder
- Automatic tool change (A.T.C)
- Ceramic ball bearings
- Labyrinth with air seal
- Sensors s1, s2, s3, s5
- Grease lubrication
- Taper cleaning

ROBOTECH PX-HX



SUITABLE FOR MACHINING WOOD, PLASTICS, ALUMINUM AND COMPOSITES
POWER UP TO 20 KW AND HIGH TORQUES FOR HEAVY MACHINING
OPTIMAL DESIGN FOR BI-ROTARY HEADS (50° AND 90°)
AND ROBOT APPLICATIONS
AVAILABLE WITH ENCODER ON BOARD,
LONG NOSE WITH 3 FRONT BEARINGS, AIR TOOL, MQL AND OIL MIST
AVAILABLE WITH HSK63F, HSK 63E AND HSK 63A

LAYOUT PX HSK 63F

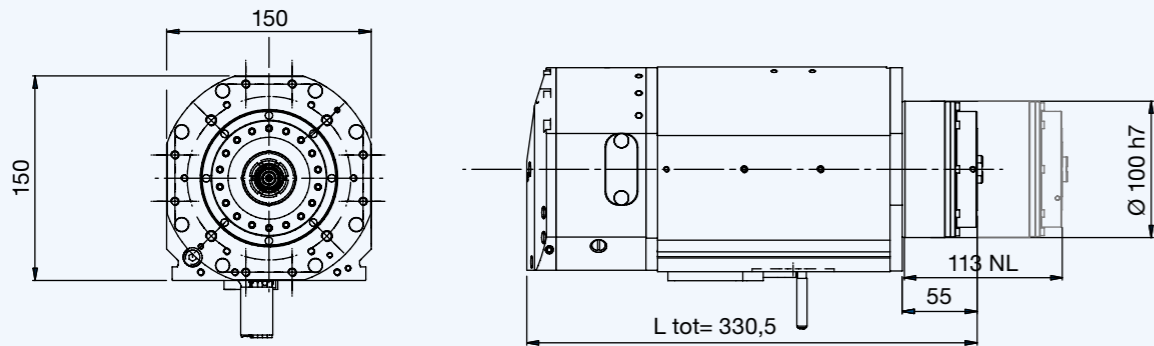

LAYOUT HX HSK 63F

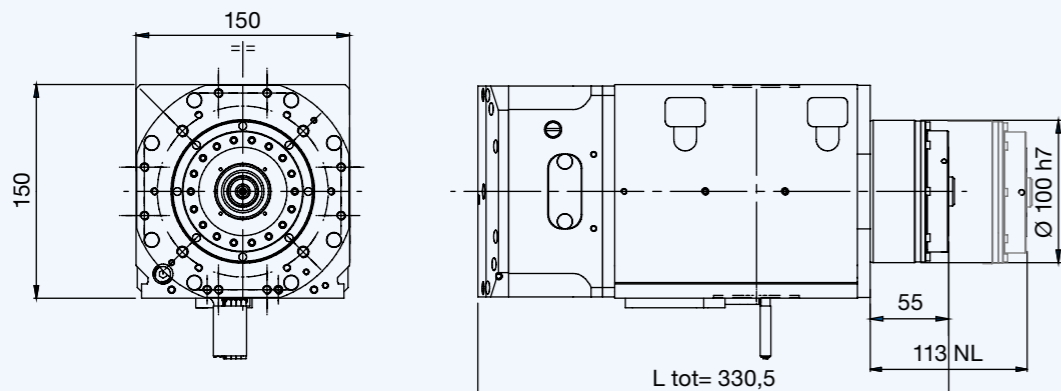

PX/HX-2 10/7 24

HIGH TORQUE

PRESTAZIONI / PERFORMANCES

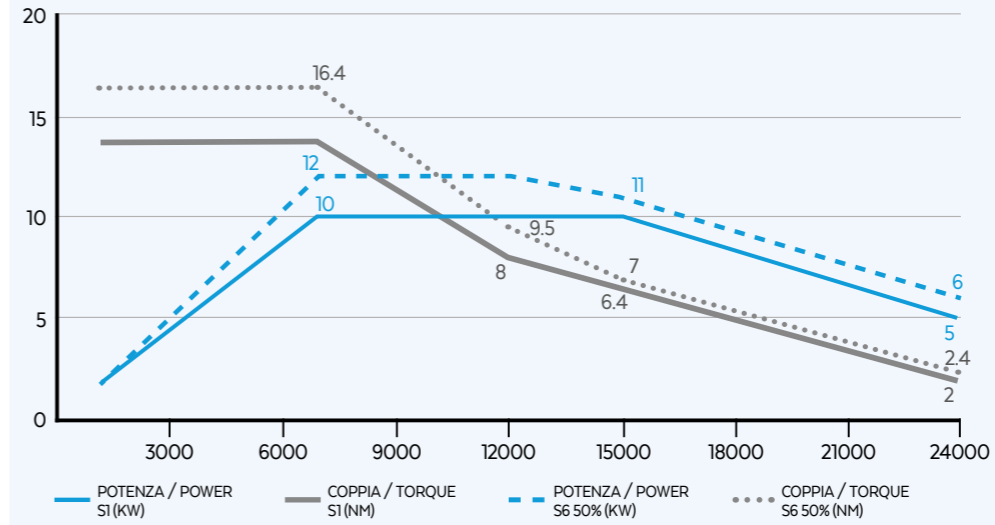

OPZIONALI / OPTIONS

- Encoder TVpp or TTL
- Long nose
- Air tool
- Oil mist/MQL
- Anti-rotation sleeves
- Bearings temperature monitoring
- Speed monitoring
- Vibration sensor
- HSK 63E/63A

SPECIFICHE TECNICHE / TECHNICAL SPECIFICATIONS

- Power: 10/12 kW
- Torque: 13.6/16.4 Nm
- Speed: 24000 rpm
- Current: 21/25 A
- Voltage: 380 Volt
- Weight: 25 kg
- Supply: inverter

EQUIPAGGIAMENTO / EQUIPMENT

- HSK 63F
- Ceramic ball bearings
- Taper cleaning
- Liquid cooling
- Labyrinth with air seal
- Single effect pneumatic cylinder
- Sensors s1, s2, s3, s5
- Automatic tool change (A.T.C)
- Grease lubrication

PX/HX-2 13/7 24

HIGH TORQUE

PRESTAZIONI / PERFORMANCES

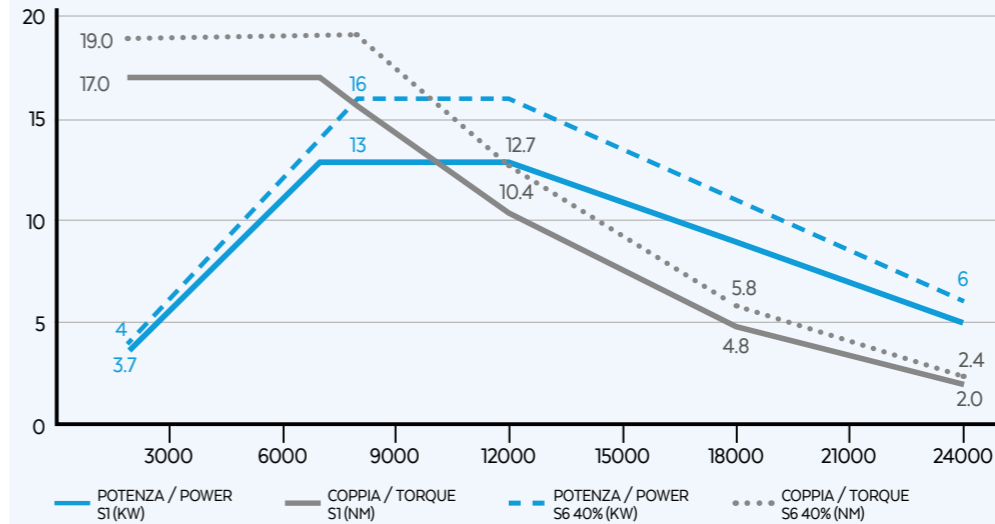

OPZIONALI / OPTIONS

- Encoder TVpp or TTL
- Long nose
- Air tool
- Oil mist/MQL
- Anti-rotation sleeves
- Bearings temperature monitoring
- Speed monitoring
- Vibration sensor
- HSK 63E/63A



SPECIFICHE TECNICHE / TECHNICAL SPECIFICATIONS

- Power: 13/16 kW
- Torque: 17/19 Nm
- Speed: 24000 rpm
- Current: 35/39 A
- Voltage: 380 Volt
- Weight: 23 kg
- Supply: inverter

EQUIPAGGIAMENTO / EQUIPMENT

- HSK 63F
- Ceramic ball bearings
- Taper cleaning
- Liquid cooling
- Labyrinth with air seal
- Single effect pneumatic cylinder
- Sensors s1, s2, s3, s5
- Automatic tool change (A.T.C)
- Grease lubrication

PX/HX-2 12/12 24

PRESTAZIONI / PERFORMANCES

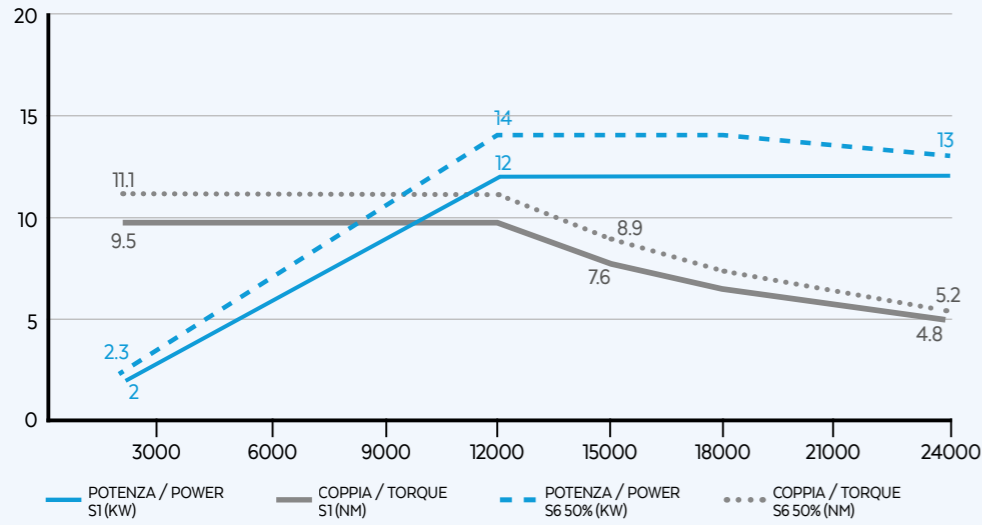

OPZIONALI / OPTIONS

- Encoder 1Vpp or TTL
- Long nose
- Air tool
- Oil mist/MQL
- Anti-rotation sleeves
- Bearings temperature monitoring
- Speed monitoring
- Vibration sensor
- HSK 63E/63A

SPECIFICHE TECNICHE / TECHNICAL SPECIFICATIONS

- S1-S6 kW** 12/14
- S1-S6 A** 26/29
- Pol es** 4
- S1-S6 Nm** 9.5/11.1
- Volt** 380
- Supply** inverter
- rpm** 24000
- kg** 25

EQUIPAGGIAMENTO / EQUIPMENT

- HSK 63F
- Liquid cooling
- Single effect pneumatic cylinder
- Automatic tool change (A.T.C)
- Ceramic ball bearings
- Labyrinth with air seal
- Sensors s1, s2, s3, s5
- Grease lubrication
- Taper cleaning

PX/HX-2 15/12 24

PRESTAZIONI / PERFORMANCES

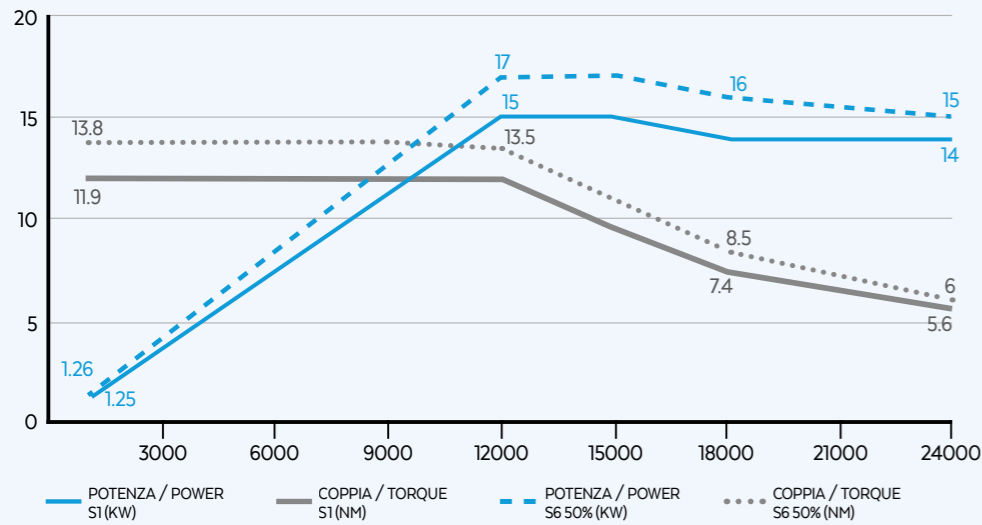

OPZIONALI / OPTIONS

- Encoder 1Vpp or TTL
- Long nose
- Air tool
- Oil mist/MQL
- Anti-rotation sleeves
- Bearings temperature monitoring
- Speed monitoring
- Vibration sensor
- HSK 63E/63A

SPECIFICHE TECNICHE / TECHNICAL SPECIFICATIONS

- S1-S6 kW** 15/17
- S1-S6 A** 30/33
- Pol es** 4
- S1-S6 Nm** 11.9/13.8
- Volt** 380
- Supply** inverter
- rpm** 24000
- kg** 25

EQUIPAGGIAMENTO / EQUIPMENT

- HSK 63F
- Liquid cooling
- Single effect pneumatic cylinder
- Automatic tool change (A.T.C)
- Ceramic ball bearings
- Labyrinth with air seal
- Sensors s1, s2, s3, s5
- Grease lubrication
- Taper cleaning

PX/HX-2 18/12 24

PRESTAZIONI / PERFORMANCES

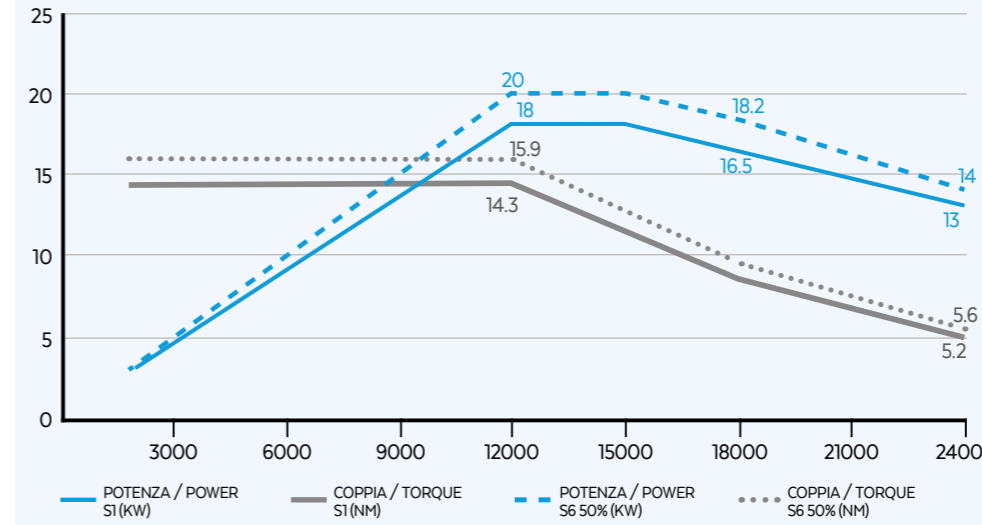

OPZIONALI / OPTIONS

- Encoder 1Vpp or TTL
- Long nose
- Air tool
- Oil mist/MQL
- Anti-rotation sleeves
- Bearings temperature monitoring
- Speed monitoring
- Vibration sensor
- HSK 63E/63A

SPECIFICHE TECNICHE / TECHNICAL SPECIFICATIONS

- S1-S6 kW** 18/20
- S1-S6 A** 35/38.5
- Pol es** 4
- S1-S6 Nm** 14.3/15.9
- Volt** 380
- Supply** inverter
- rpm** 24000
- kg** 25

EQUIPAGGIAMENTO / EQUIPMENT

- HSK 63F
- Liquid cooling
- Single effect pneumatic cylinder
- Automatic tool change (A.T.C)
- Ceramic ball bearings
- Labyrinth with air seal
- Sensors s1, s2, s3, s5
- Grease lubrication
- Taper cleaning

PX/HX-2 20/10 24 (SYNCHRONOUS)

PRESTAZIONI / PERFORMANCES

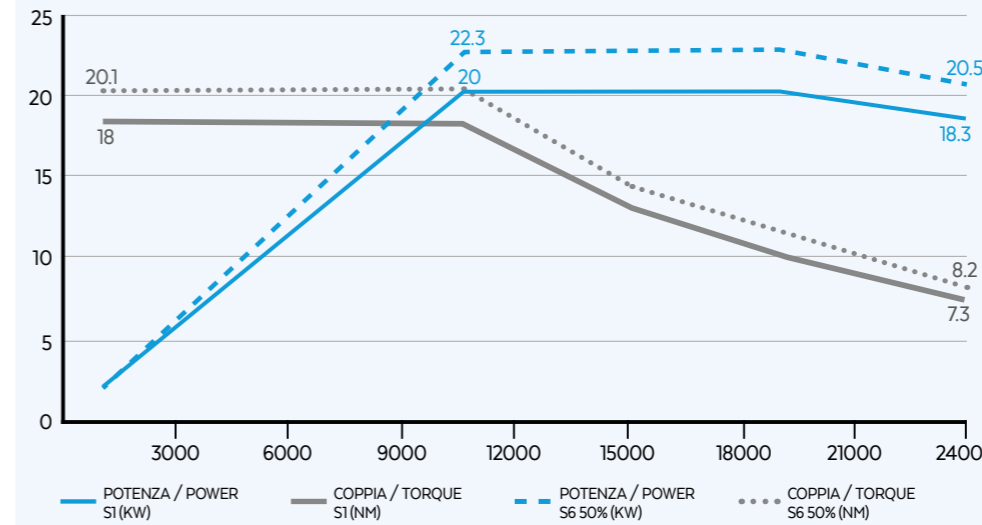

OPZIONALI / OPTIONS

- Long nose
- Air tool
- Oil mist/MQL
- Anti-rotation sleeves
- Bearings temperature monitoring
- Speed monitoring
- Vibration sensor
- HSK 63E

SPECIFICHE TECNICHE / TECHNICAL SPECIFICATIONS

- S1-S6 kW** 20/22.3
- S1-S6 A** 48/50
- Pol es** 4
- S1-S6 Nm** 17.8/20.1
- Volt** 380
- Supply** inverter
- rpm** 24000
- kg** 25

EQUIPAGGIAMENTO / EQUIPMENT

- HSK 63A
- Liquid cooling
- Single effect pneumatic cylinder
- Automatic tool change (A.T.C)
- Ceramic ball bearings
- Labyrinth with air seal
- Sensors s1, s2, s3, s5
- Grease lubrication
- Taper cleaning
- Encoder 1Vpp

ROBOTECH HX 3C

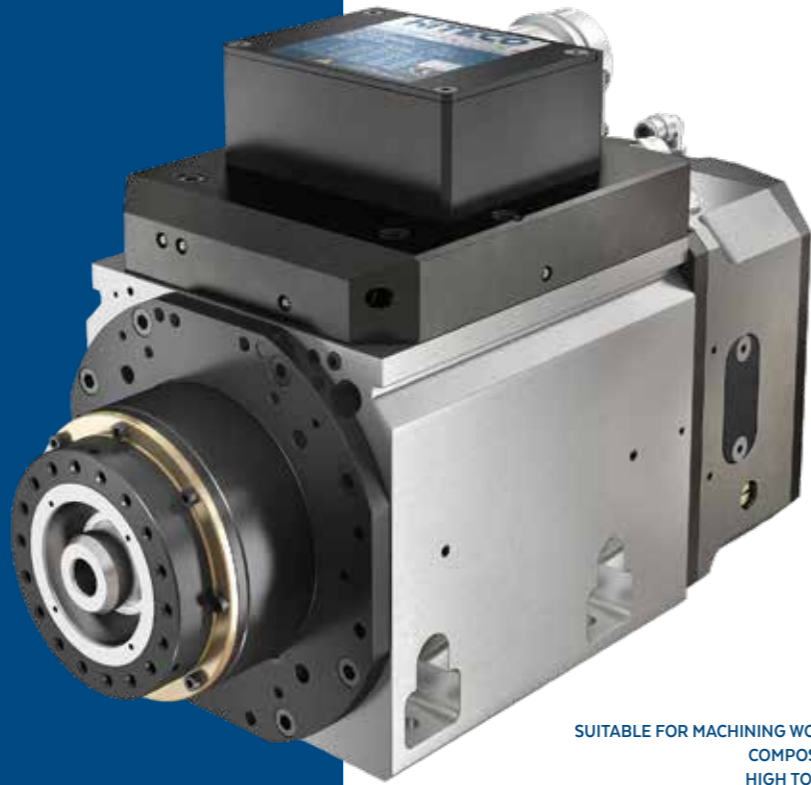

SUITABLE FOR MACHINING WOOD, PLASTICS, ALUMINUM AND COMPOSITES POWER UP TO 20 KW AND HIGH TORQUES FOR HEAVY MACHINING
OPTIMAL DESIGN FOR 3-AXIS MACHINES CONNECTION TO THE MACHINE WITH COMMERCIAL CONNECTORS AVAILA WITH ENCODER ON BOARD, LONG NOSE WITH 23 FRONT BEARINGS, AIR TOOL, MQL AND OIL MIST

LAYOUT HSK 63F 3C

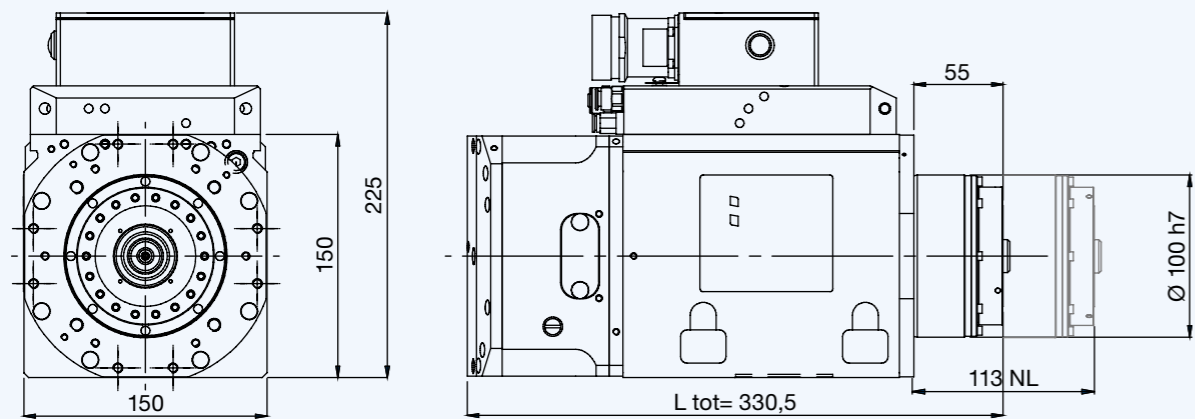

HIGH TORQUE

HX-2 10/7 24 3C

PRESTAZIONI / PERFORMANCES

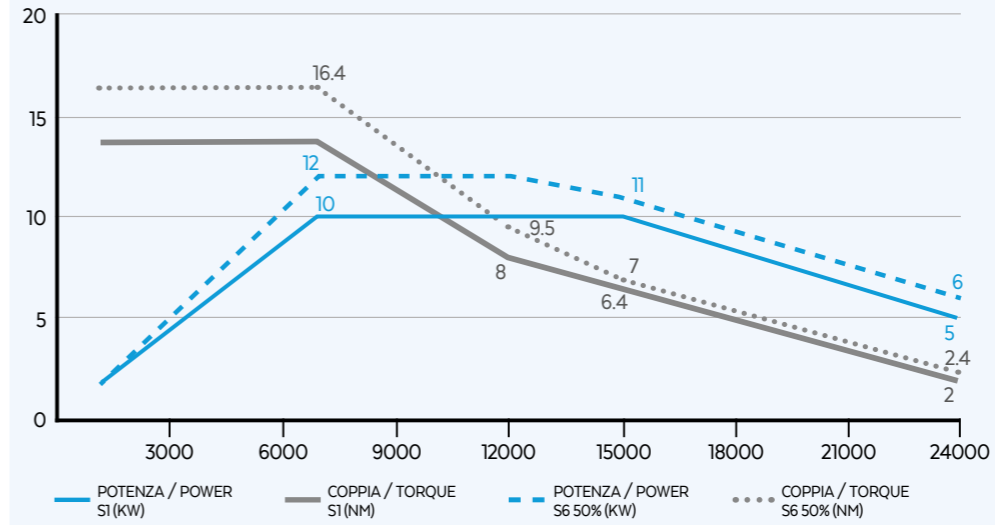

OPZIONALI / OPTIONS

- Encoder TVpp or TTL
- Circular connector cc machine side
- Long nose
- Air tool
- Oil mist/MQL
- Bearings temperature monitoring
- Speed monitoring
- Vibration sensor
- HSK 63E/63A
- Anti-rotation sleeves

SPECIFICHE TECNICHE / TECHNICAL SPECIFICATIONS

- S1-S6 kW 10/12
- S1-S6 Nm 13.6/16.4
- rpm 24000
- S1-S6 A 21/25
- Volt 380
- kg 25
- Pol es 4
- Supply inverter

EQUIPAGGIAMENTO / EQUIPMENT

- HSK 63F
- Ceramic ball bearings
- Circular connector cc spindle side
- Liquid cooling
- Labyrinth with air seal
- Taper cleaning

- Single effect pneumatic cylinder
- Sensors s1, s2, s3, s5
- Automatic tool change (A.T.C)
- Grease lubrication

HX-2 12/12 24 3C

PRESTAZIONI / PERFORMANCES

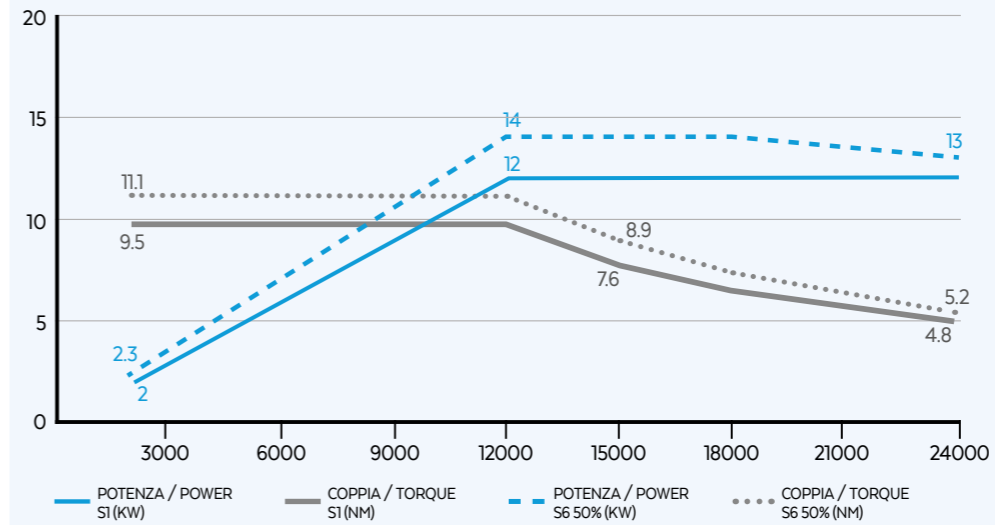

OPZIONALI / OPTIONS

- Encoder TVpp or TTL
- Circular connector cc machine side
- Long nose
- Air tool
- Oil mist/MQL
- Bearings temperature monitoring
- Speed monitoring
- Vibration sensor
- HSK 63E/63A
- Anti-rotation sleeves

SPECIFICHE TECNICHE / TECHNICAL SPECIFICATIONS

- S1-S6 kW 12/14
- S1-S6 Nm 9.5/11.1
- rpm 24000
- S1-S6 A 26/29
- Volt 380
- kg 25
- Pol es 4
- Supply inverter

EQUIPAGGIAMENTO / EQUIPMENT

- HSK 63F
- Ceramic ball bearings
- Circular connector cc spindle side
- Liquid cooling
- Labyrinth with air seal
- Taper cleaning

- Single effect pneumatic cylinder
- Sensors s1, s2, s3, s5
- Automatic tool change (A.T.C)
- Grease lubrication

HX-2 13/7 24

HIGH TORQUE

PRESTAZIONI / PERFORMANCES

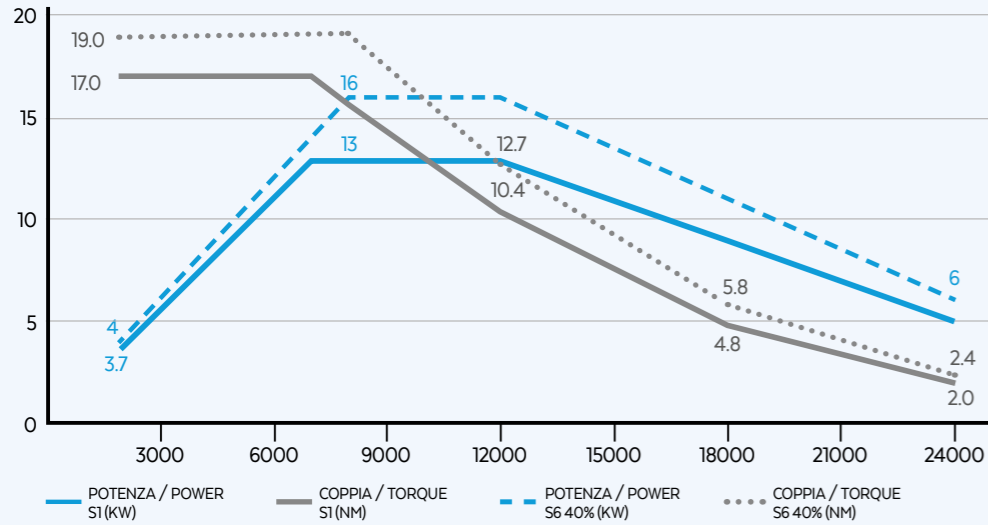

OPZIONALI / OPTIONS

- Encoder TVpp or TTL
- Long nose
- Air tool
- Oil mist/MQL
- Anti-rotation sleeves
- Bearings temperature monitoring
- Speed monitoring
- Vibration sensor
- HSK 63E/63A



SPECIFICHE TECNICHE / TECHNICAL SPECIFICATIONS

- S1-S6 kW 13/14
- S1-S6 A 35/39
- Pol es 6
- S1-S6 Nm 17/19
- Volt 380
- Supply inverter
- rpm 24000
- kg 23

EQUIPAGGIAMENTO / EQUIPMENT

- HSK 63F
- Liquid cooling
- Single effect pneumatic cylinder
- Automatic tool change (A.T.C)
- Ceramic ball bearings
- Labyrinth with air seal
- Sensors s1, s2, s3, s5
- Grease lubrication
- Taper cleaning

HX-2 18/12 24 3C

PRESTAZIONI / PERFORMANCES

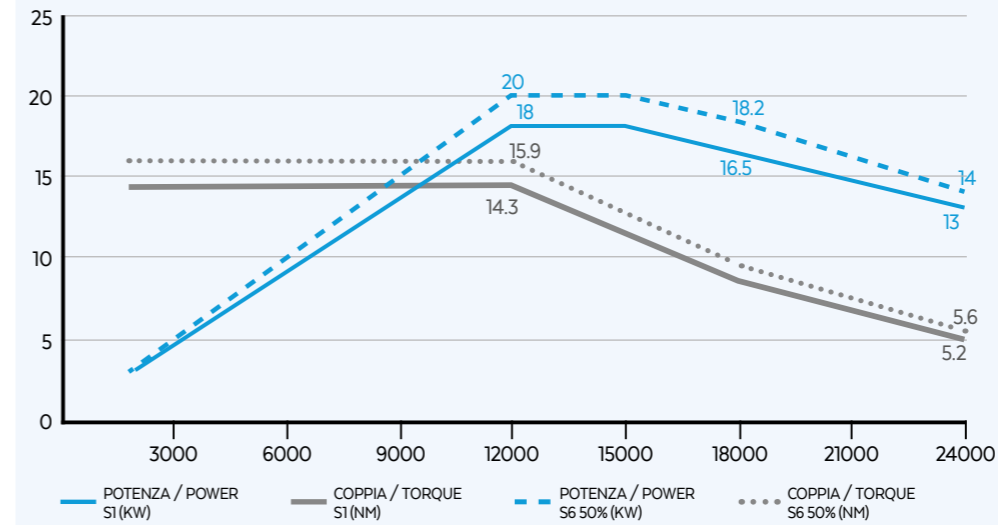

OPZIONALI / OPTIONS

- Encoder TVpp or TTL
- Circular connector cc machine side
- Long nose
- Air tool
- Oil mist/MQL
- Bearings temperature monitoring
- Speed monitoring
- Vibration sensor
- HSK 63E/63A
- Anti-rotation sleeves

SPECIFICHE TECNICHE / TECHNICAL SPECIFICATIONS

- S1-S6 kW 18/20
- S1-S6 A 35/38.5
- Pol es 4
- S1-S6 Nm 14.3/15.9
- Volt 380
- Supply inverter
- rpm 24000
- kg 25

EQUIPAGGIAMENTO / EQUIPMENT

- HSK 63F
- Liquid cooling
- Single effect pneumatic cylinder
- Automatic tool change (A.T.C)
- Ceramic ball bearings
- Labyrinth with air seal
- Sensors s1, s2, s3, s5
- Grease lubrication
- Taper cleaning
- Circular connector cc spindle side

HX-2 15/12 24 3C

PRESTAZIONI / PERFORMANCES

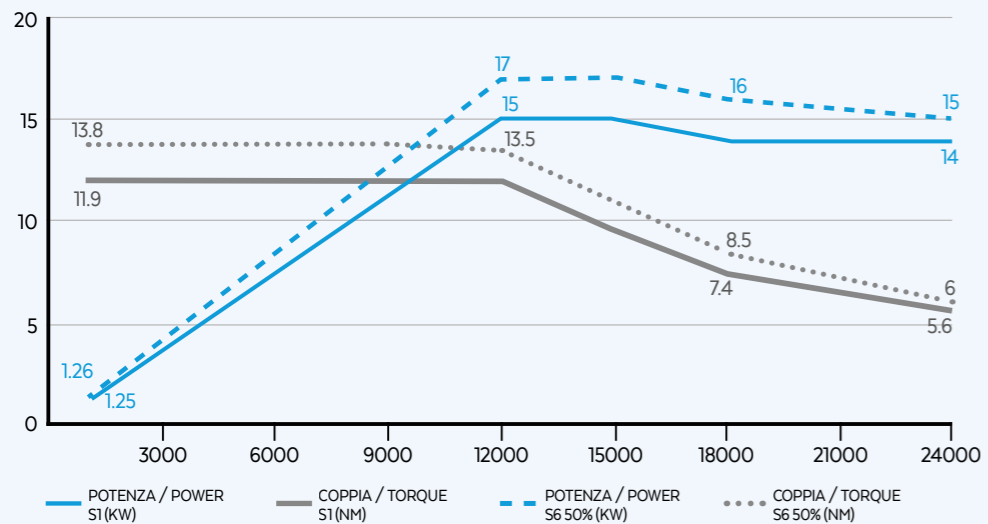

OPZIONALI / OPTIONS

- Encoder TVpp or TTL
- Circular connector cc machine side
- Long nose
- Air tool
- Oil mist/MQL
- Bearings temperature monitoring
- Speed monitoring
- Vibration sensor
- HSK 63E/63A
- Anti-rotation sleeves

SPECIFICHE TECNICHE / TECHNICAL SPECIFICATIONS

- S1-S6 kW 15/17
- S1-S6 A 30/33
- Pol es 4
- S1-S6 Nm 11.9/13.8
- Volt 380
- Supply inverter
- rpm 24000
- kg 25

EQUIPAGGIAMENTO / EQUIPMENT

- HSK 63F
- Liquid cooling
- Single effect pneumatic cylinder
- Automatic tool change (A.T.C)
- Ceramic ball bearings
- Labyrinth with air seal
- Sensors s1, s2, s3, s5
- Grease lubrication
- Taper cleaning
- Circular connector cc spindle side

HX-2 20/10 24 3C (SYNCHRONOUS)

PRESTAZIONI / PERFORMANCES

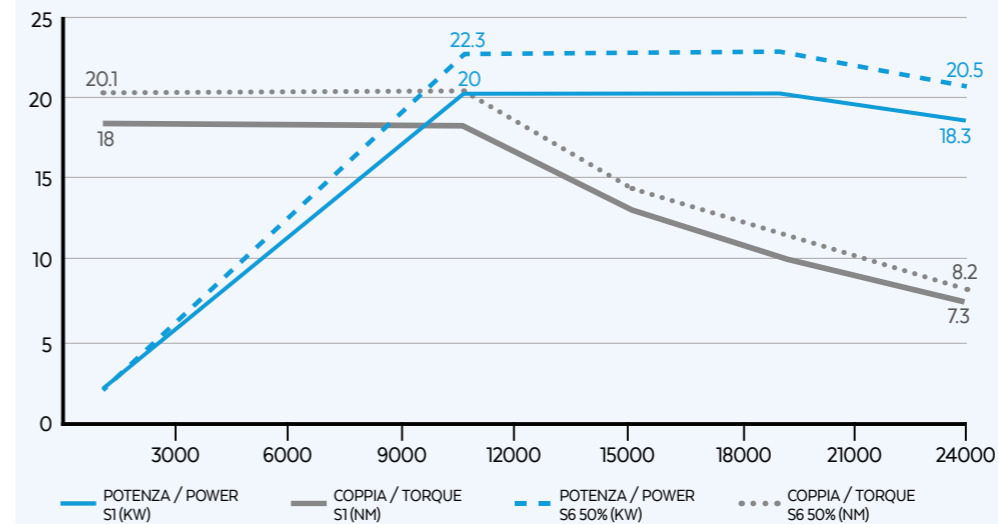

OPZIONALI / OPTIONS

- Long nose
- Air tool
- Oil mist/MQL
- Circular connector cc machine side
- Anti-rotation sleeves
- Bearings temperature monitoring
- Speed monitoring
- Vibration sensor
- HSK 63E

SPECIFICHE TECNICHE / TECHNICAL SPECIFICATIONS

- S1-S6 kW 20/22.3
- S1-S6 A 48/50
- Pol es 4
- S1-S6 Nm 17.8/20.1
- Volt 380
- Supply inverter
- rpm 24000
- kg 25

EQUIPAGGIAMENTO / EQUIPMENT

- HSK 63A
- Liquid cooling
- Single effect pneumatic cylinder
- Automatic tool change (A.T.C)
- Ceramic ball bearings
- Labyrinth with air seal
- Sensors s1, s2, s3, s5
- Grease lubrication
- Taper cleaning
- Circular connector cc spindle side
- Encoder TVpp

ROBOTECH HD



SUITABLE FOR MACHINING ALUMINUM AND COMPOSITES
OPTIMAL DESIGN FOR BIROTARY HEADS (90°)
TWO INDEPENDENT TOOL LUBRICATION CHANNELS
ANTI-ROTATION PRESET FOR AGGREGATE CONNECTION
AVAILABLE WITH HSK 50F AND HSK 40E

HD-2 5.6/18 20

PRESTAZIONI / PERFORMANCES

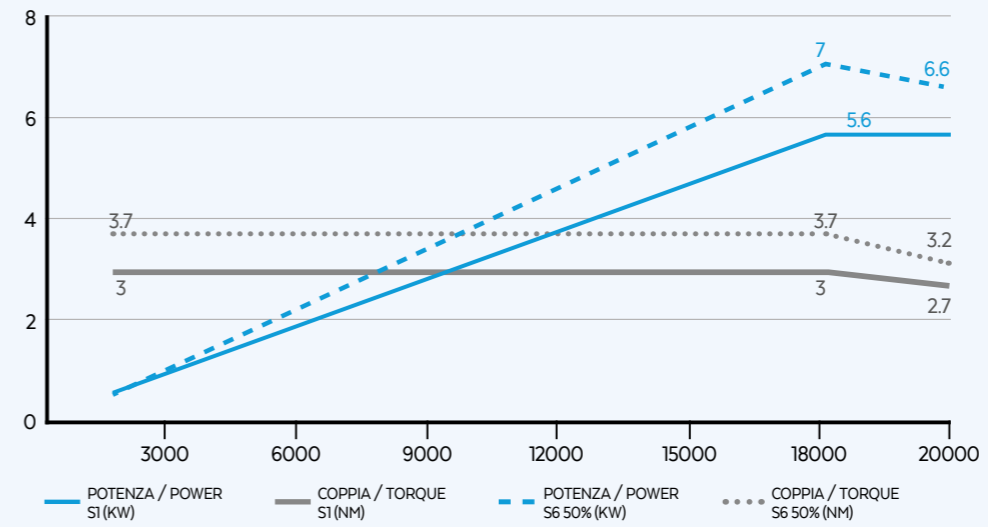

OPZIONALI / OPTIONS

- Encoder TVpp or TTL
- HSK 40E
- Sensor s5
- Anti-rotation sleeves

SPECIFICHE TECNICHE / TECHNICAL SPECIFICATIONS

- Power: 5.6/7 kW
- Current: 12/14 A
- Pol: 4
- Speed: 3/3.7 rpm
- Voltage: 380 Volt
- Supply: inverter
- Max speed: 20000 rpm
- Weight: 18 kg

EQUIPAGGIAMENTO / EQUIPMENT

- HSK 50F
- Liquid cooling
- Single effect pneumatic cylinder
- Automatic tool change (A.T.C)
- Ceramic ball bearings
- Labyrinth with air seal
- Sensors s1, s2, s3
- Grease lubrication
- Taper cleaning

LAYOUT HSK 50F

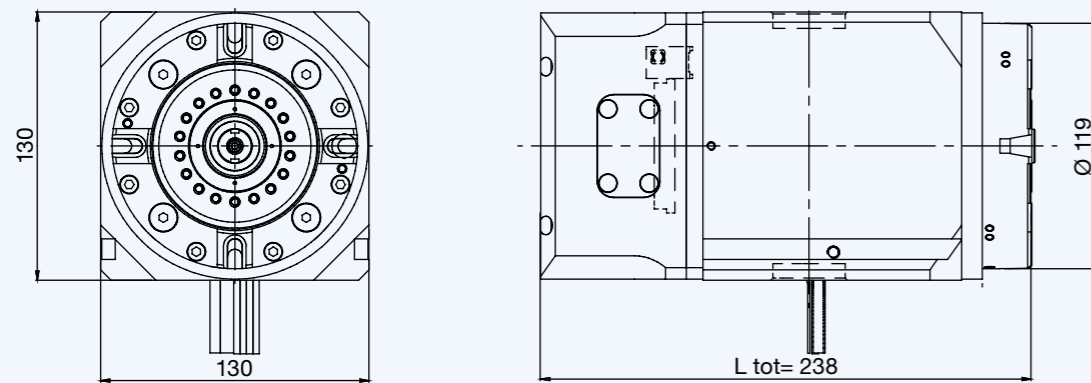

ROBOTECH
QT



SUITABLE FOR MACHINING WOODEN BEAMS
POWER UP TO 25 KW AND HIGH TORQUES FOR HEAVY MACHINING
OPTIMAL DESIGN FOR 90° BIROTARY HEADS (50° AND 90°)
AVAILABLE WITH HSK 63E

LAYOUT HSK 63E

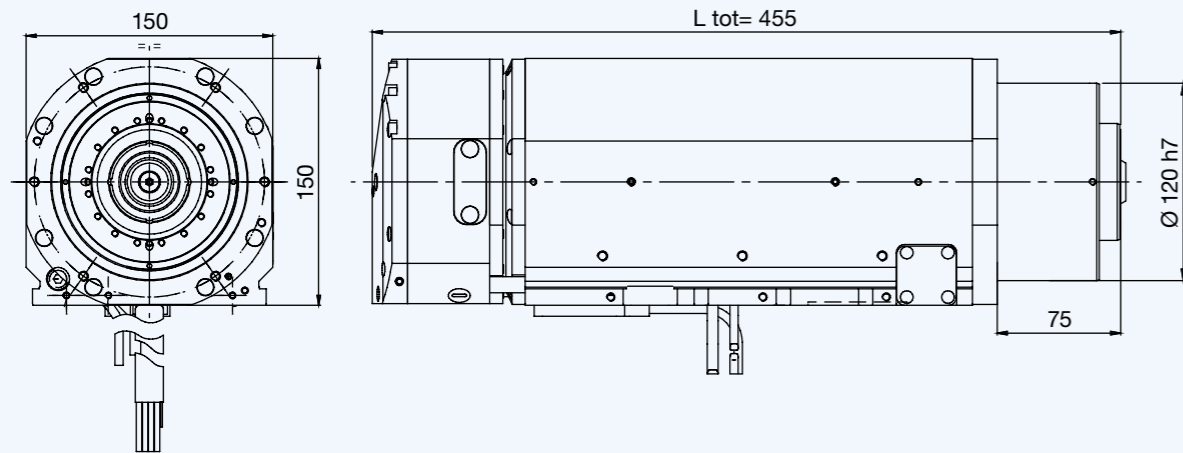

QT-2 13/6 16

LIQUID HIGH TORQUE

PRESTAZIONI / PERFORMANCES

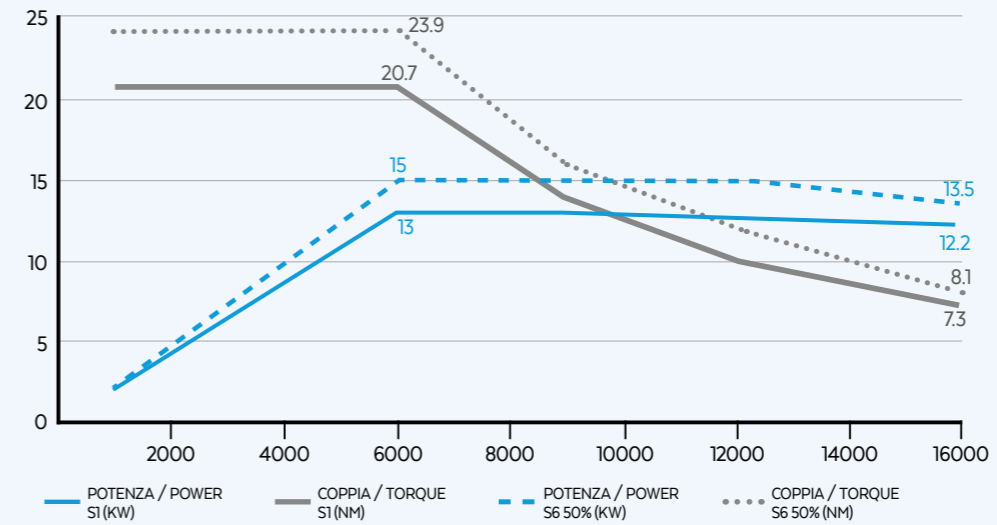

OPZIONALI / OPTIONS

- Encoder TVpp or TTL
- plate and pp cable connection

SPECIFICHE TECNICHE / TECHNICAL SPECIFICATIONS

- S1-S6 kW 13/15
- S1-S6 A 30/35
- Pol es 4
- S1-S6 Nm 20.7/23.9
- Volt 400
- Supply inverter
- rpm 16000
- kg 36

EQUIPAGGIAMENTO / EQUIPMENT

- HSK 63E
- Liquid cooling
- Single effect pneumatic cylinder
- Automatic tool change (A.T.C)
- Ceramic ball bearings
- Labyrinth with air seal
- Sensors S1, S2, S3, S5
- Grease lubrication
- Taper cleaning

QT-2 16/6 16

LIQUID HIGH TORQUE

PRESTAZIONI / PERFORMANCES

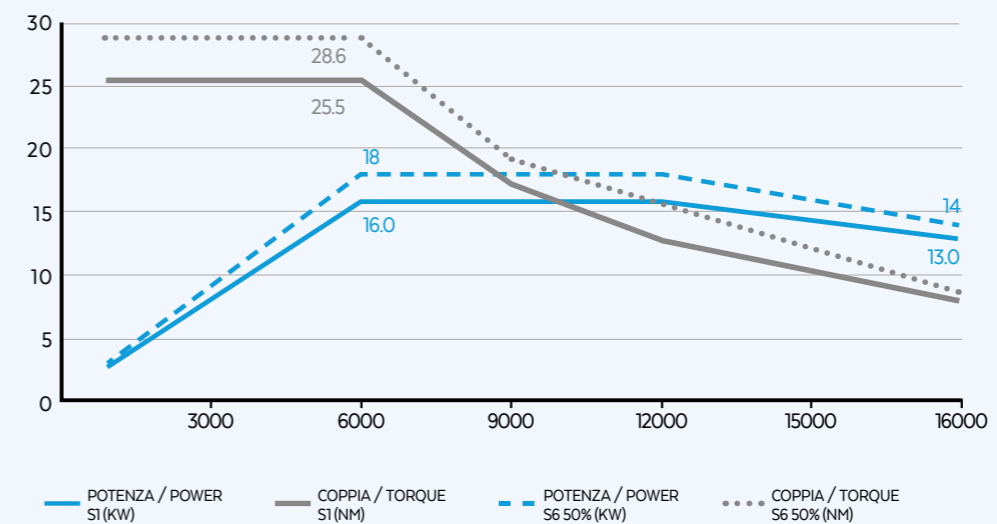

OPZIONALI / OPTIONS

- plate and pp cable connection
- NEW

SPECIFICHE TECNICHE / TECHNICAL SPECIFICATIONS

- S1-S6 kW 16/18
- S1-S6 A 47/56
- Pol es 4
- S1-S6 Nm 25.5/28.6
- Volt 400
- Supply inverter
- rpm 16000
- kg 36

EQUIPAGGIAMENTO / EQUIPMENT

- HSK 63E
- Liquid cooling
- Single effect pneumatic cylinder
- Automatic tool change (A.T.C)
- Ceramic ball bearings
- Labyrinth with air seal
- Sensors S1, S2, S3, S5
- Grease lubrication
- Taper cleaning
- Encoder TVpp or TTL

PRESTAZIONI / PERFORMANCES

OPZIONALI / OPTIONS

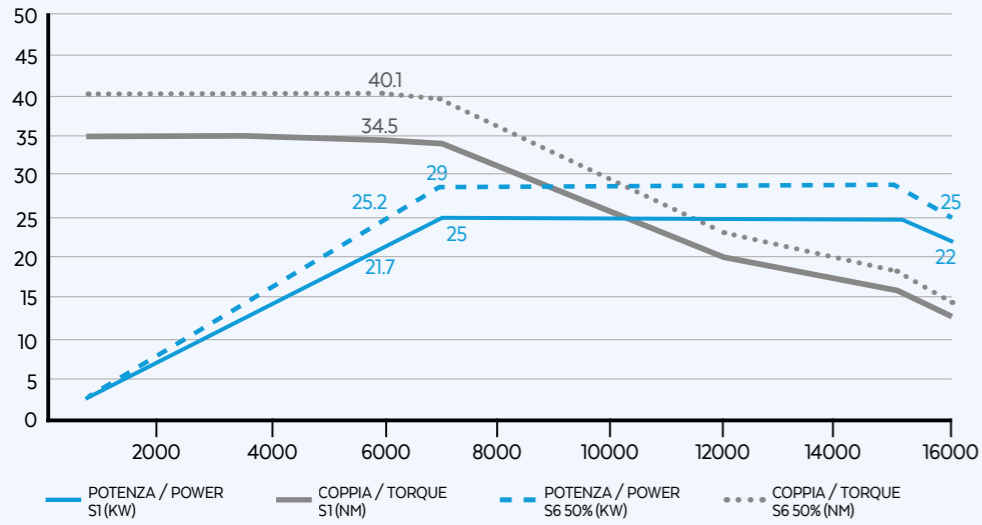

SPECIFICHE TECNICHE / TECHNICAL SPECIFICATIONS

S1-S6 kW 25/29	S1-S6 A 47/56	Pol es 4
S1-S6 Nm 34.5/40.1	Volt 400	Sup ply inverter
rpm 16000	kg 36	

EQUIPAGGIAMENTO / EQUIPMENT

HSK 63E	Liquid cooling	Single effect pneumatic cylinder	Automatic tool change (A.T.C.)
Ceramic ball bearings	Labyrinth with air seal	Sensors S1,S2,S3,S5	Grease lubrication
Taper cleaning	Encoder 1Vpp or TTL		

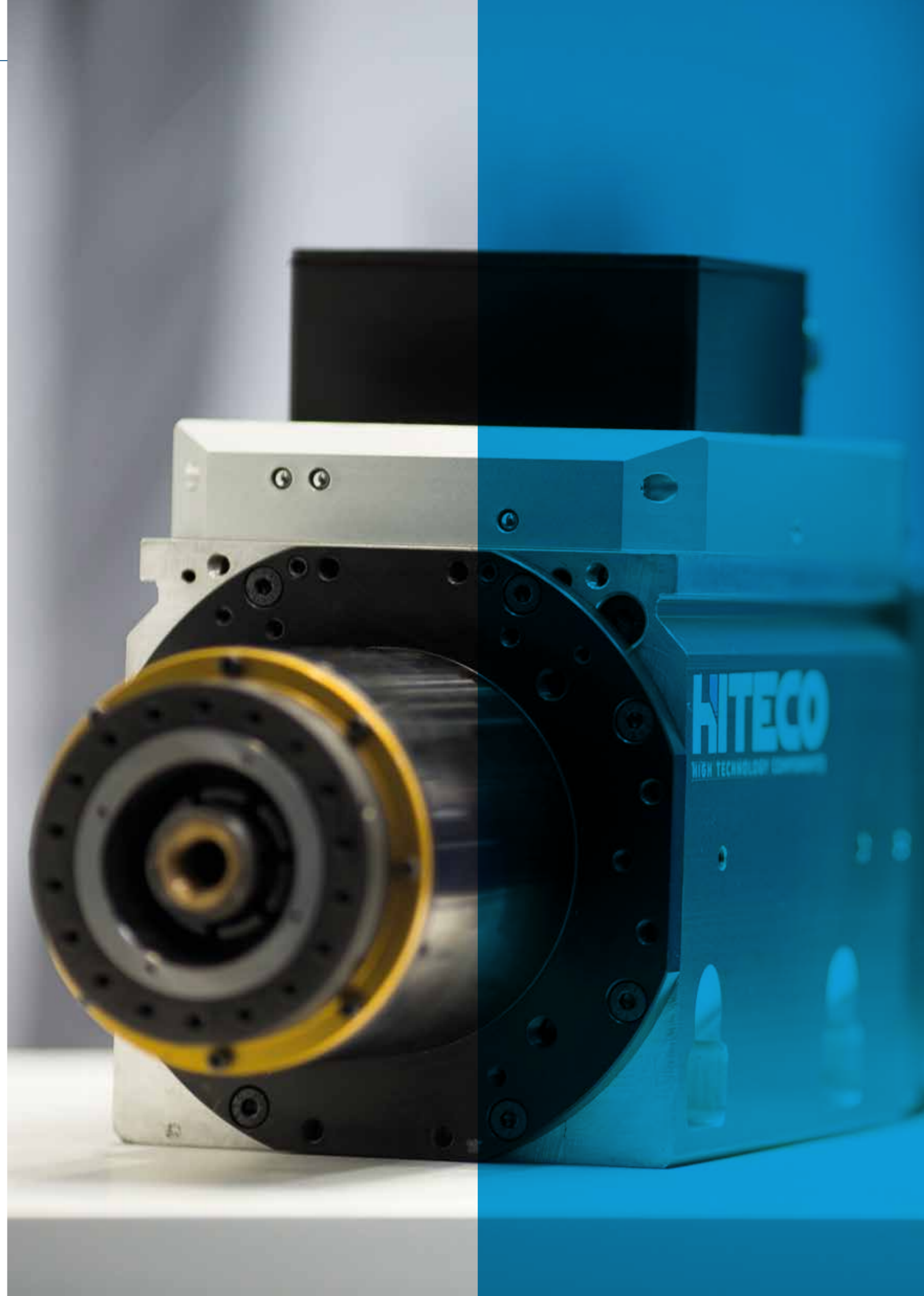

ROBOTECH HT



SUITABLE FOR MACHINING WOOD AND ALUMINUM
 POWER UP TO 25 KW AND HIGH TORQUES FOR HEAVY MACHINING
 OPTIMAL DESIGN FOR 3 AND 5-AXIS MACHINES
 AVAILABLE WITH ENCODER ON BOARD, LONG NOSE WITH
 3 FRONT BEARINGS, AIR TOOL, MQL AND OIL MIST
 AVAILABLE WITH HSK 63E

LAYOUT HSK 63E

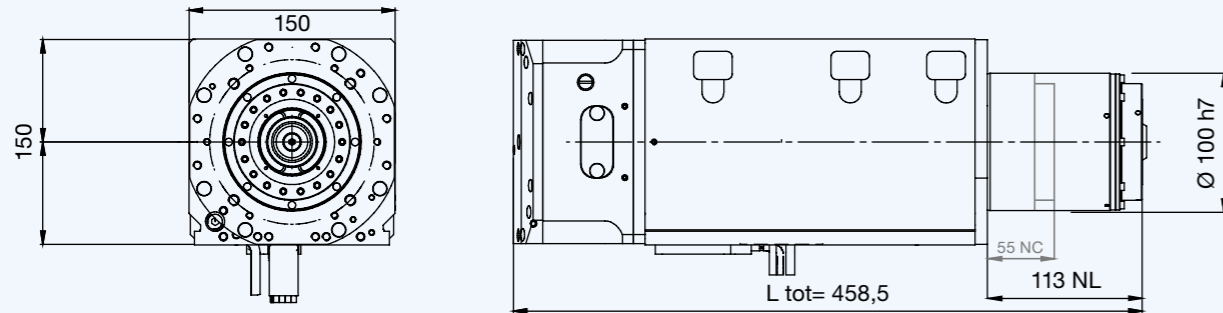

LAYOUT HSK 63E 3C

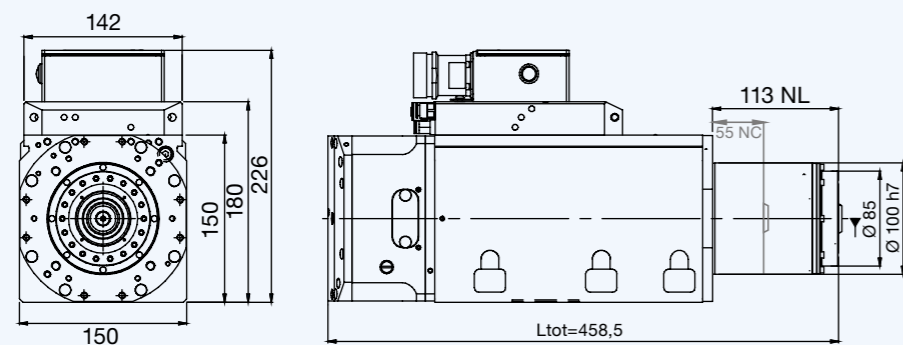

HT-2 25/10 18

SHORT NOSE

PRESTAZIONI / PERFORMANCES

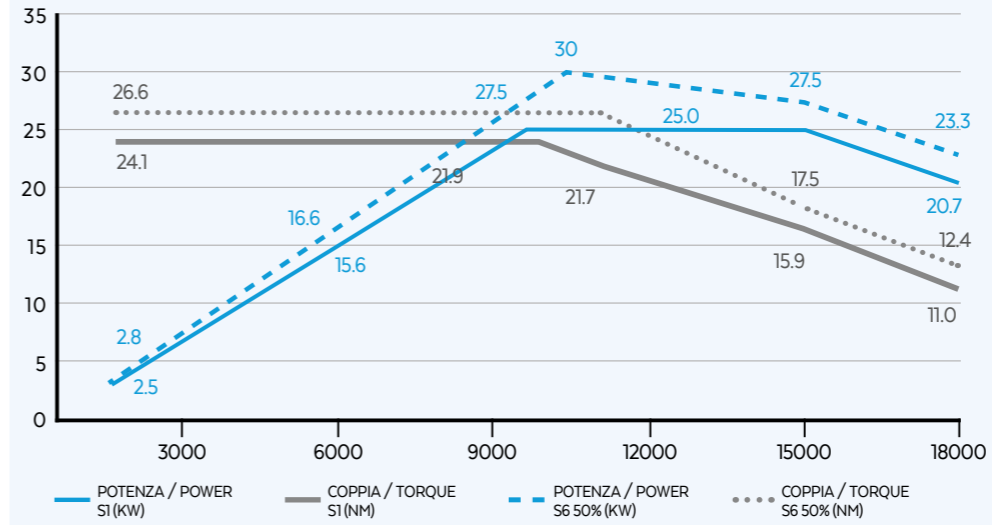

OPZIONALI / OPTIONS

- Encoder TVpp or TTL
- Oil mist/MQL
- Circular connector cc machine side
- HSK 63E/63A
- Anti-rotation sleeves
- Bearings temperature monitoring
- Speed monitoring
- Vibration sensor
- Air tool

SPECIFICHE TECNICHE / TECHNICAL SPECIFICATIONS

- S1-S6 kW** 25/27.5
- S1-S6 Nm** 24.1/26.6
- rpm** 18000
- S1-S6 A** 56/62
- Volt** 380
- kg** 42
- Pol es 4
- Supply inverter

EQUIPAGGIAMENTO / EQUIPMENT

- HSK 63F
- Ceramic ball bearings
- Circular connector cc spindle side
- Liquid cooling
- Labyrinth with air seal
- Taper cleaning
- Single effect pneumatic cylinder
- Sensors s1, s2, s3, s5
- Short nose
- Automatic tool change (A.T.C)
- Grease lubrication

HT-2 25/10 24

LONG NOSE

PRESTAZIONI / PERFORMANCES

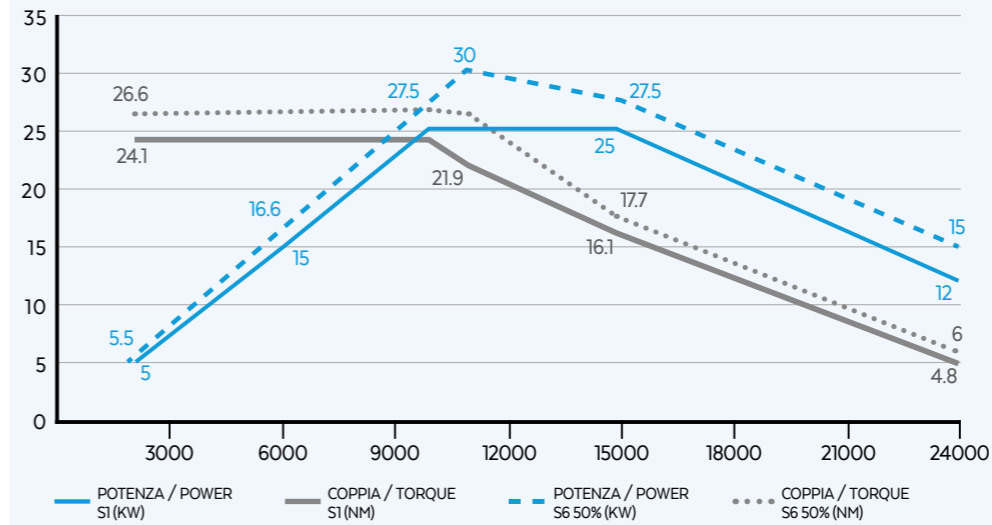

OPZIONALI / OPTIONS

- Encoder TVpp or TTL
- Oil mist/MQL
- Circular connector cc machine side
- HSK 63E/63A
- Anti-rotation sleeves
- Bearings temperature monitoring
- Speed monitoring
- Vibration sensor
- Air tool

SPECIFICHE TECNICHE / TECHNICAL SPECIFICATIONS

- S1-S6 kW** 25/30
- S1-S6 Nm** 24.2/26.6
- rpm** 24000
- S1-S6 A** 53/60
- Volt** 380
- kg** 42
- Pol es 4
- Supply inverter

EQUIPAGGIAMENTO / EQUIPMENT

- HSK 63F
- Ceramic ball bearings
- Circular connector cc spindle side
- Liquid cooling
- Labyrinth with air seal
- Taper cleaning
- Single effect pneumatic cylinder
- Sensors s1, s2, s3, s5
- Long nose
- Automatic tool change (A.T.C)
- Grease lubrication

ROBOTECH QM



SUITABLE FOR INTENSE MACHINING OF WOOD, ALUMINUM AND LIGHT ALLOY
 POWER UP TO 30 KW AND HIGH TORQUES
 AVAILABLE WITH ENCODER ON BOARD, AIR TOOL, MQL AND OIL MIST
 AVAILABLE WITH HSK80F, HSK85S AND HSK63A

LAYOUT HSK 63A

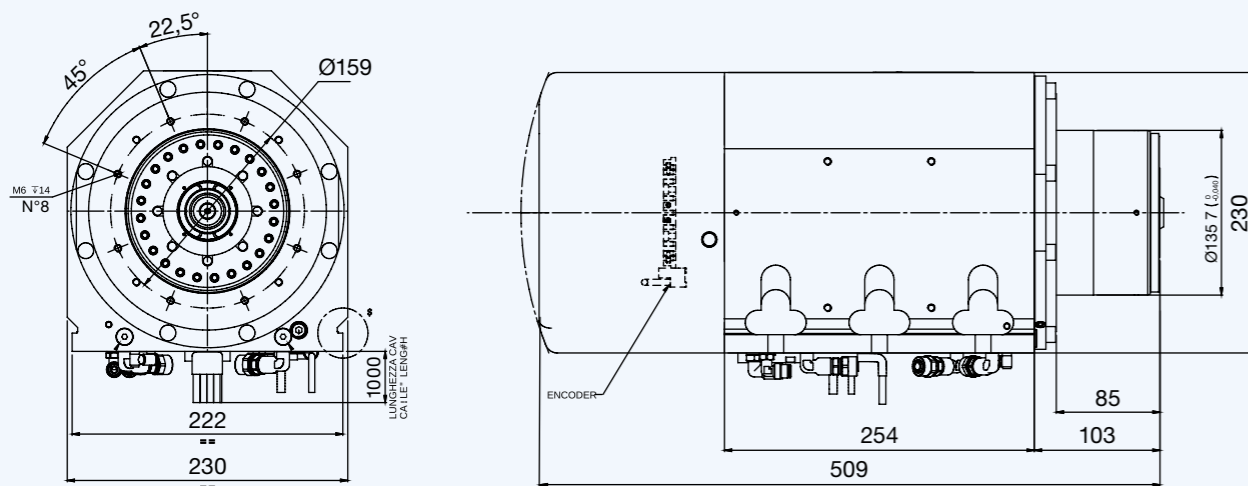

QM-2 30/6 13

HIGH TORQUE

PRESTAZIONI / PERFORMANCES

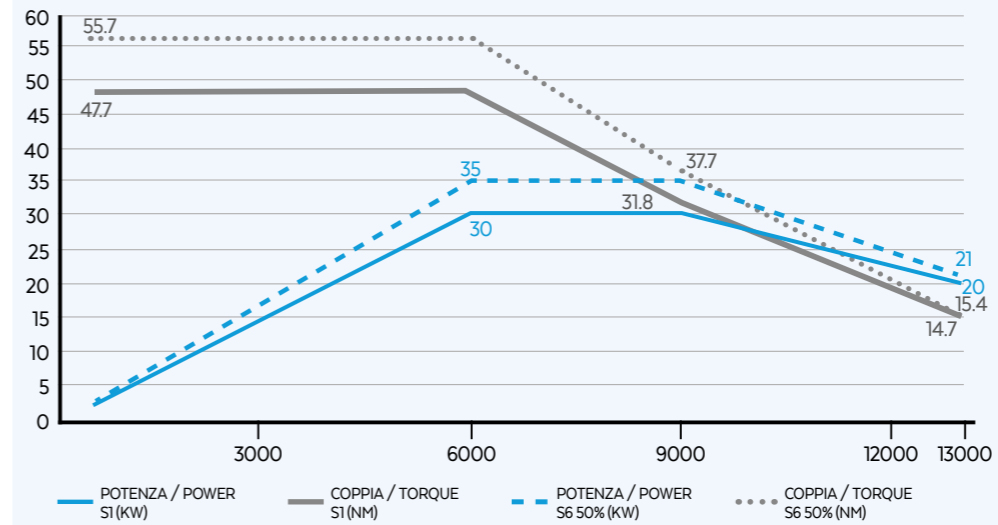

OPZIONALI / OPTIONS

- Air tool
- Sensor s5
- Oil mist/MQL
- HSK 80F
- Bearings temperature monitoring
- Speed monitoring
- Vibration sensor
- HSK 85S

SPECIFICHE TECNICHE / TECHNICAL SPECIFICATIONS

- Power: 30/35 kW
- Torque: 47.7/55.7 Nm
- Speed: 13000 rpm
- Current: 59/65 A
- Voltage: 380 Volt
- Weight: 75 kg
- Pol es 4
- Supply inverter

EQUIPAGGIAMENTO / EQUIPMENT

- HSK 63A
- Ceramic ball bearings
- Taper cleaning
- Liquid cooling
- Labyrinth with air seal
- Encoder 1Vpp
- Single effect pneumatic cylinder
- Sensors s1, s2, s3
- Automatic tool change (A.T.C)
- Grease lubrication

QM-2 44/6 13

HIGH TORQUE

PRESTAZIONI / PERFORMANCES

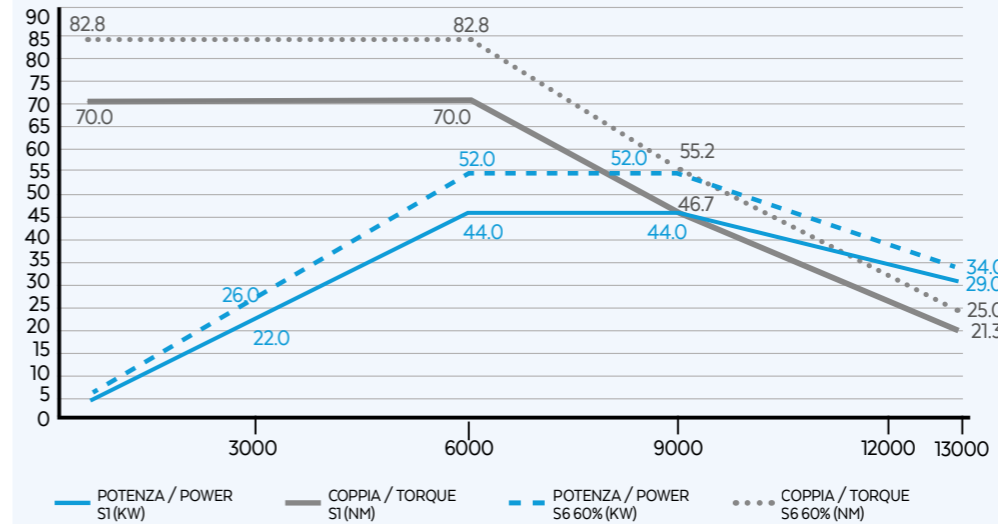

OPZIONALI / OPTIONS

- Air tool
- Sensor s5
- Oil mist/MQL
- HSK 80F
- Bearings temperature monitoring
- Speed monitoring
- Vibration sensor
- HSK 85S

SPECIFICHE TECNICHE / TECHNICAL SPECIFICATIONS

- Power: 44/52 kW
- Torque: 70/82.8 Nm
- Speed: 13000 rpm
- Current: 85/107 A
- Voltage: 380 Volt
- Weight: 76 kg
- Pol es 4
- Supply inverter

EQUIPAGGIAMENTO / EQUIPMENT

- HSK 63A
- Ceramic ball bearings
- Taper cleaning
- Liquid cooling
- Labyrinth with air seal
- Encoder 1Vpp
- Single effect pneumatic cylinder
- Sensors s1, s2, s3
- Automatic tool change (A.T.C)
- Grease lubrication

ROBOTECH QM 3C



SUITABLE FOR INTENSE MACHINING OF WOOD, ALUMINUM AND LIGHT ALLOY
POWER UP TO 30 KW AND HIGH TORQUES
AVAILABLE WITH ENCODER ON BOARD, AIR TOOL, MQL AND OIL MIST
AVAILABLE WITH HSK80F, HSK85S AND HSK63A

LAYOUT HSK 63A 3C

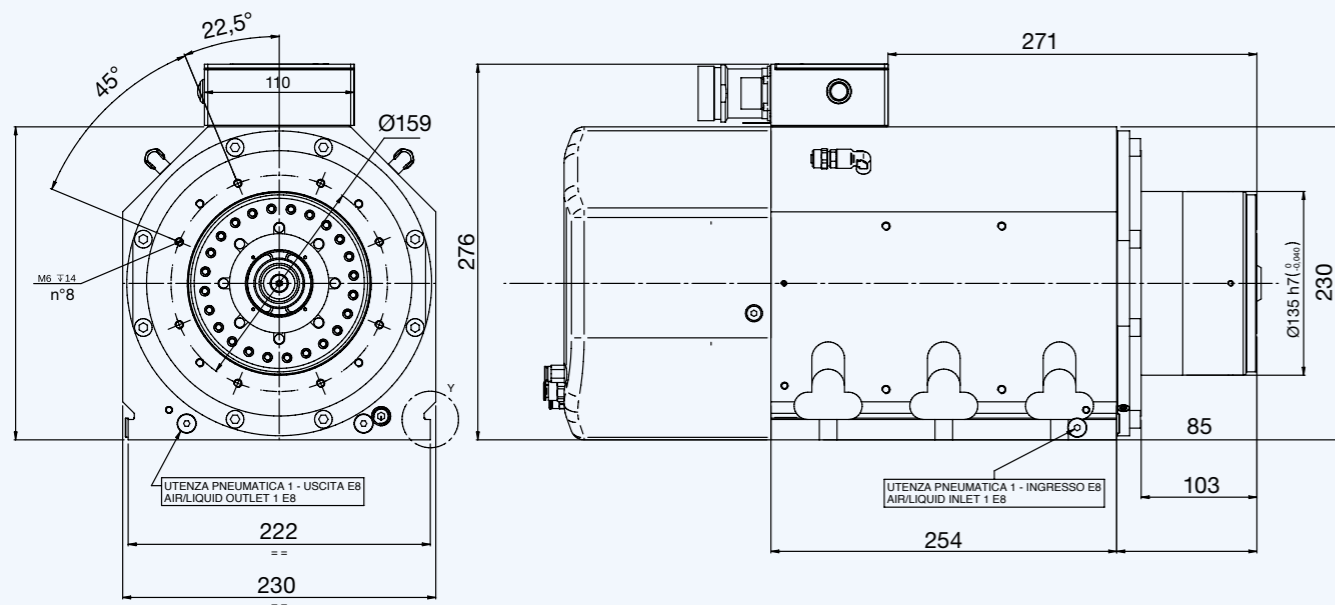

QM-2 30/6 13

HIGH TORQUE

PRESTAZIONI / PERFORMANCES

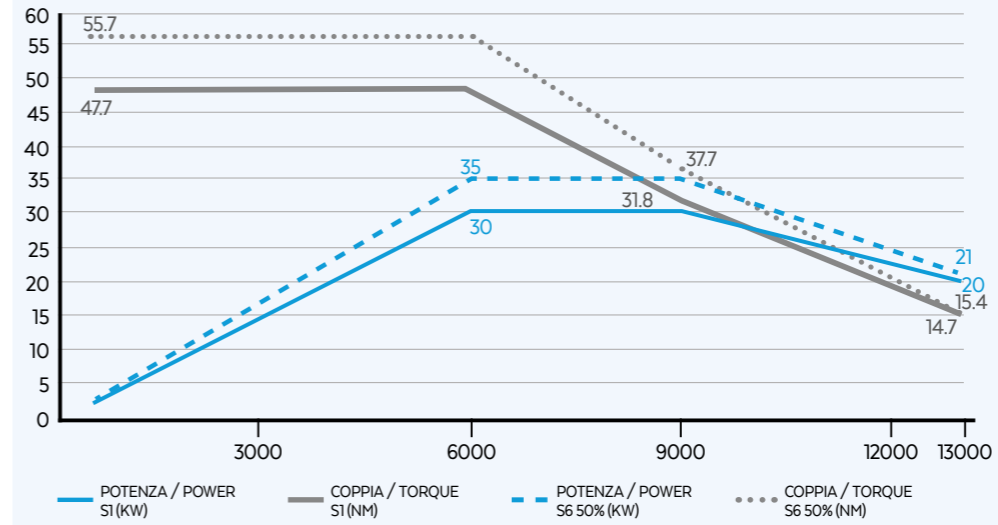

OPZIONALI / OPTIONS

- Air tool
- Sensor s5
- Oil mist/MQL
- HSK 80F
- Bearings temperature monitoring
- Speed monitoring
- Vibration sensor
- HSK 85S

SPECIFICHE TECNICHE / TECHNICAL SPECIFICATIONS

- S1-S6 kW 30/35
- S1-S6 Nm 47.7/55.7
- rpm 13000
- S1-S6 A 59/65
- Volt 380
- kg 75
- Pol es 4
- Supply inverter

EQUIPAGGIAMENTO / EQUIPMENT

- HSK 63A
- Ceramic ball bearings
- Taper cleaning
- Liquid cooling
- Labyrinth with air seal
- Encoder 1Vpp
- Single effect pneumatic cylinder
- Sensors s1, s2, s3
- Automatic tool change (A.T.C)
- Grease lubrication

QM-2 44/6 13

HIGH TORQUE

PRESTAZIONI / PERFORMANCES

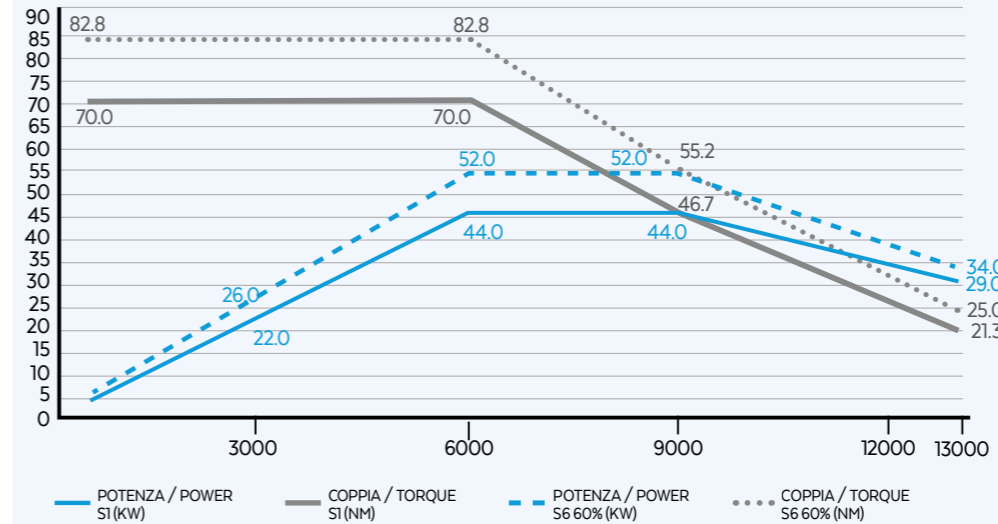

OPZIONALI / OPTIONS

- Air tool
- Sensor s5
- Oil mist/MQL
- HSK 80F
- Bearings temperature monitoring
- Speed monitoring
- Vibration sensor
- HSK 85S

SPECIFICHE TECNICHE / TECHNICAL SPECIFICATIONS

- S1-S6 kW 44/52
- S1-S6 Nm 70/82.8
- rpm 13000
- S1-S6 A 85/107
- Volt 380
- kg 76
- Pol es 4
- Supply inverter

EQUIPAGGIAMENTO / EQUIPMENT

- HSK 63A
- Ceramic ball bearings
- Taper cleaning
- Liquid cooling
- Labyrinth with air seal
- Encoder 1Vpp
- Single effect pneumatic cylinder
- Sensors s1, s2, s3
- Automatic tool change (A.T.C)
- Grease lubrication

METALTECH KX



SUITABLE FOR MACHINING METAL, ALUMINUM AND LIGHT ALLOY
POWER UP TO 32 KW AND HIGH TORQUES UP TO 100 NM
FRONT BEARING COOLING CIRCUIT
AVAILABLE WITH ENCODER ON BOARD, AIR TOOL, MQL, OIL MIST AND CTS
SYNCHRONOUS SPINDLES WITH HSK 63A AND ENCODER ON BOARD

LAYOUT HSK 63A

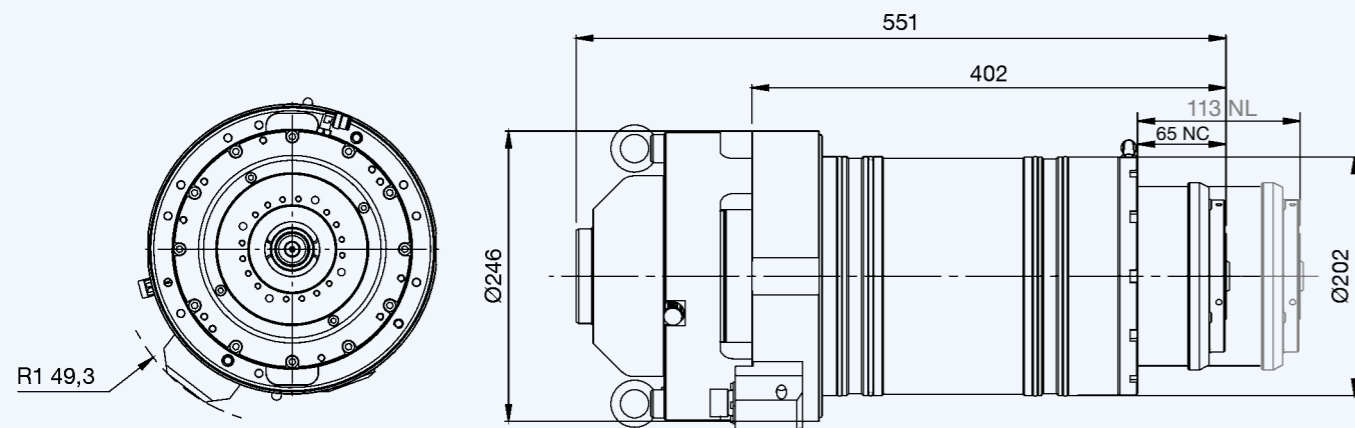

ALTRI LAYOUT / OTHER LAYOUTS

	ΔL	L tot
NL*	+58 mm	515 mm

KX-2 31/3 15 (SYNCHRONOUS)

PRESTAZIONI / PERFORMANCES

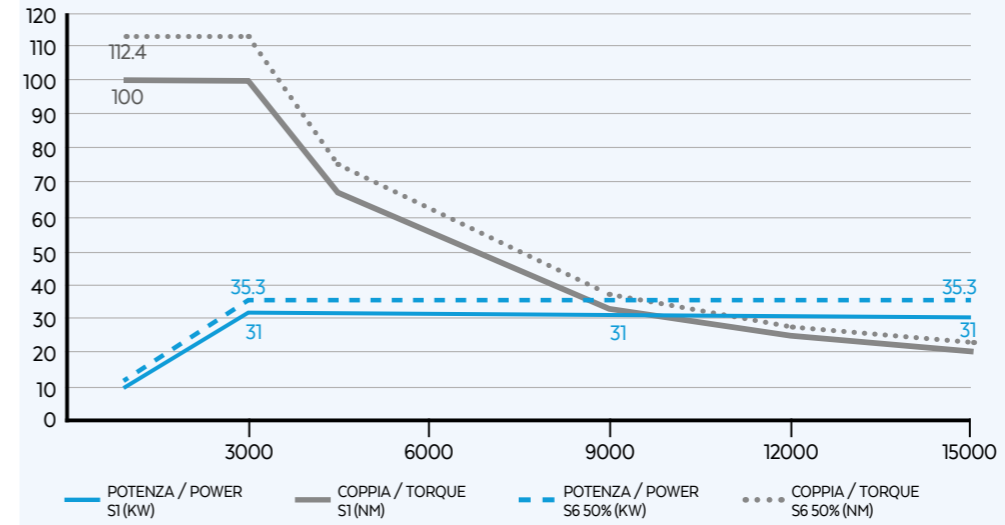

OPZIONALI / OPTIONS

- Air tool
- Water tool cooling
- Temperature sensor
- CTS lubrication
- Oil mist/MQL

SPECIFICHE TECNICHE / TECHNICAL SPECIFICATIONS

- Power: 31/35.3 kW
- Torque: 73/113 Nm
- Speed: 15000 rpm
- Voltage: 400 Volt
- Weight: 100 kg
- Pol es 4
- Supply inverter

EQUIPAGGIAMENTO / EQUIPMENT

- HSK 63A
- Ceramic ball bearings
- Encoder TVpp
- Liquid cooling
- Labyrinth with air seal
- Taper cleaning
- Single effect pneumatic cylinder
- Sensors s1, s2
- Automatic tool change (A.T.C)
- Grease lubrication

KX-2 32/4.5 24 (SYNCHRONOUS)

PRESTAZIONI / PERFORMANCES

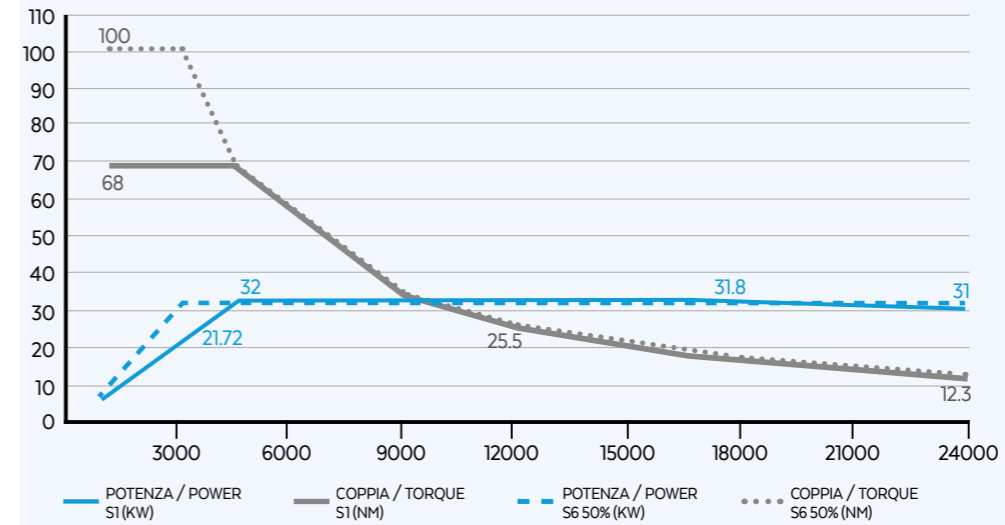

OPZIONALI / OPTIONS

- Air tool
- Water tool cooling
- Temperature sensor
- CTS lubrication
- Oil mist/MQL
- Long nose

SPECIFICHE TECNICHE / TECHNICAL SPECIFICATIONS

- Power: 32/32 kW
- Torque: 68/100 Nm
- Speed: 24000 rpm
- Voltage: 400 Volt
- Weight: 100 kg
- Pol es 4
- Supply inverter

EQUIPAGGIAMENTO / EQUIPMENT

- HSK 63A
- Ceramic ball bearings
- Encoder TVpp
- Liquid cooling
- Labyrinth with air seal
- Taper cleaning
- Single effect pneumatic cylinder
- Sensors s1, s2
- Automatic tool change (A.T.C)
- Grease lubrication

METALTECH MX

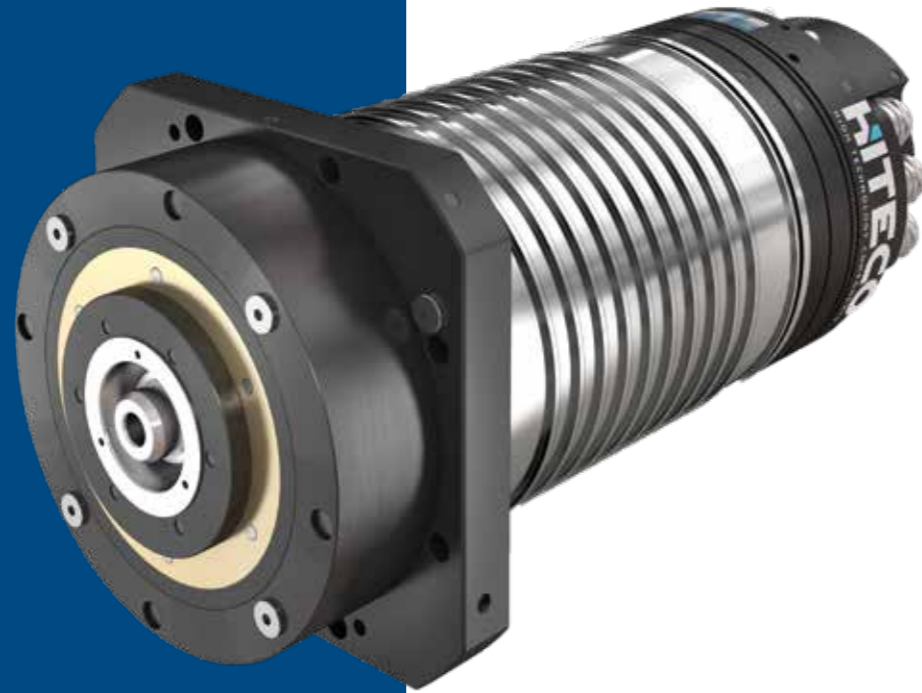

SUITABLE FOR MACHINING METAL, ALUMINUM AND LIGHT ALLOY
POWER UP TO 42 KW AND HIGH TORQUES UP TO 67 NM
FRONT BEARING COOLING CIRCUIT
AVAILABLE WITH ENCODER ON BOARD, AIR TOOL, MQL, OIL MIST AND CTS
SYNCHRONOUS SPINDLES WITH HSK 63A AND ENCODER ON BOARD

LAYOUT HSK 63A

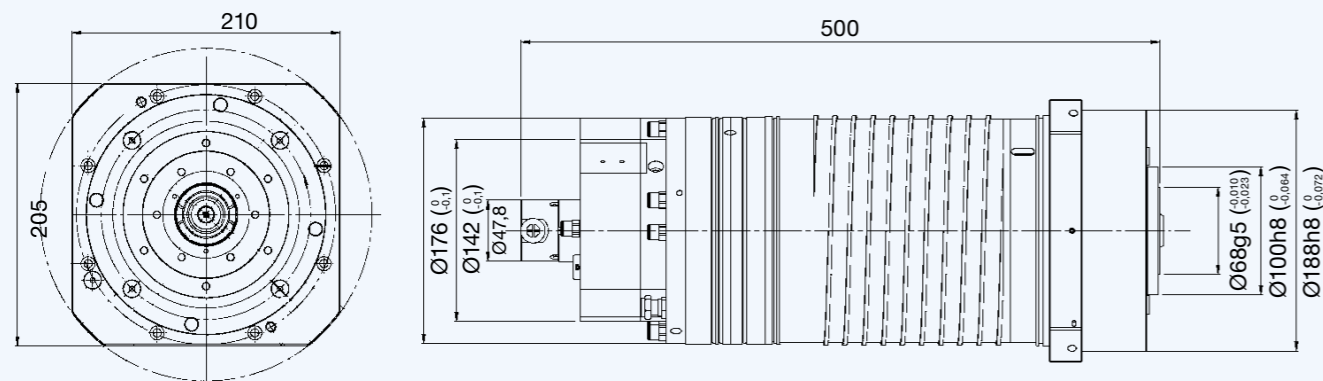

MX-2 42/6 18 63A SYNCHRONOUS

HIGH TORQUE

PRESTAZIONI / PERFORMANCES

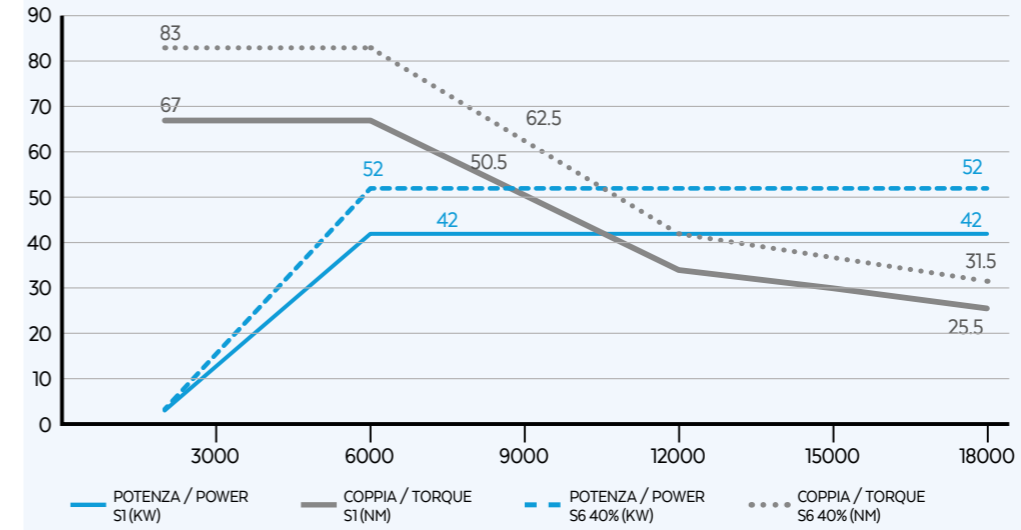

OPZIONALI / OPTIONS

- Air tool
- Temperature sensor
- CTS lubrication
- Oil mist/MQL
- Axial shaft displacement sensor
- Bearings temperature monitoring
- Speed monitoring
- Vibration sensor
- Sensor s5
- Taper cleaning

SPECIFICHE TECNICHE / TECHNICAL SPECIFICATIONS

- S1-S6 kW 42/52
- S1-S6 Nm 67/83
- S1-S6 A 120/148
- Volt 460
- kg 70
- Pol es 4
- Supply inverter
- rpm 18000

EQUIPAGGIAMENTO / EQUIPMENT

- HSK 63A
- Ceramic ball bearings
- Encoder TVpp
- Liquid cooling
- Labyrinth with air seal
- Grease lubrication
- Single effect hydraulic cylinder
- Sensors s1, s2
- Water tool cooling
- Automatic tool change (A.T.C)

MX-2 42/6 24 63A SYNCHRONOUS

HIGH TORQUE

PRESTAZIONI / PERFORMANCES

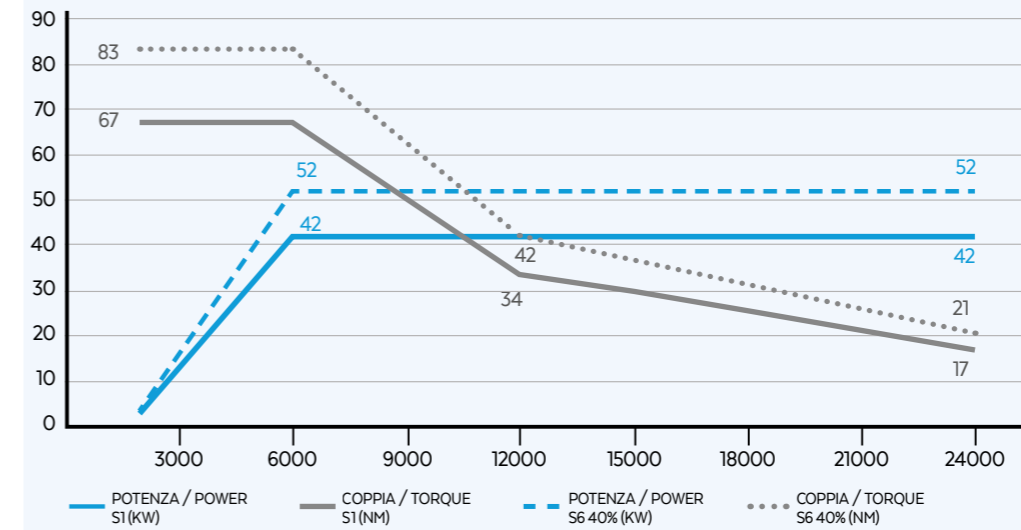

OPZIONALI / OPTIONS

- Air tool
- Temperature sensor
- CTS lubrication
- Oil mist/MQL
- Axial shaft displacement sensor
- Bearings temperature monitoring
- Speed monitoring
- Vibration sensor
- Sensor s5
- Taper cleaning

SPECIFICHE TECNICHE / TECHNICAL SPECIFICATIONS

- S1-S6 kW 42/52
- S1-S6 Nm 67/83
- S1-S6 A 120/148
- Volt 380
- kg 70
- Pol es 4
- Supply inverter
- rpm 24000

EQUIPAGGIAMENTO / EQUIPMENT

- HSK 63A
- Ceramic ball bearings
- Encoder TVpp
- Liquid cooling
- Labyrinth with air seal
- Oil lubrication
- single effect hydraulic cylinder
- Sensors s1, s2
- Water tool cooling
- Automatic tool change (A.T.C)

MX-2 42/12 20 63A

PRESTAZIONI / PERFORMANCES

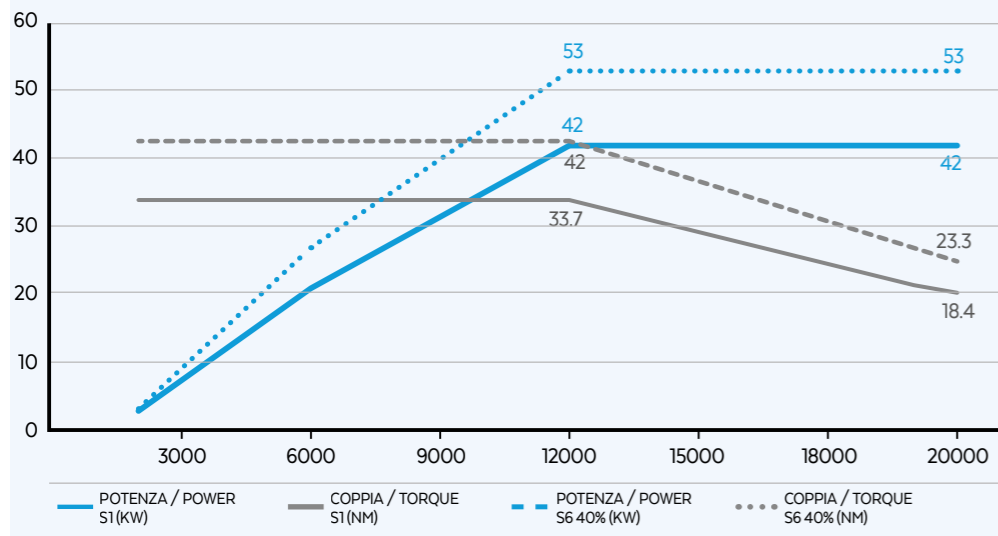

OPZIONALI / OPTIONS

- Air tool
- Temperature sensor
- CTS lubrication
- Oil mist/MQL
- Axial shaft displacement sensor
- Bearings temperature monitoring
- Speed monitoring
- Vibration sensor
- Sensor s5
- Taper cleaning

SPECIFICHE TECNICHE / TECHNICAL SPECIFICATIONS

- S1-S6 kW** 42/53
- S1-S6 Nm** 33,7/42
- rpm** 20000
- S1-S6 A** 96/112
- Volt** 380
- kg** 70
- Pol es** 6
- Supply** inverter

EQUIPAGGIAMENTO / EQUIPMENT

- HSK 63A
- Ceramic ball bearings
- Encoder TVpp
- Liquid cooling
- Labyrinth with air seal
- Grease lubrication
- Single effect hydraulic cylinder
- Sensors s1, s2
- Water tool cooling
- Automatic tool change (A.T.C)

MX-2 42/12 28 63A

PRESTAZIONI / PERFORMANCES

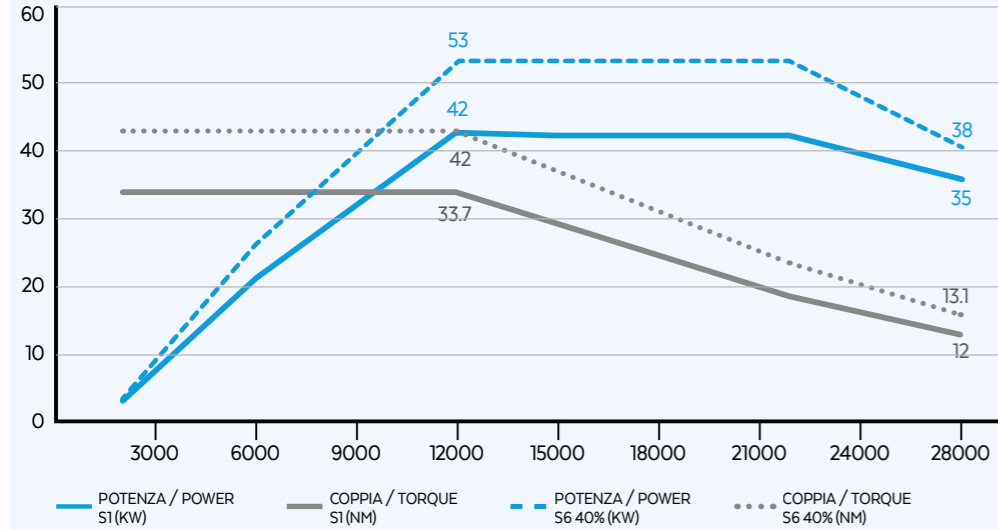

OPZIONALI / OPTIONS

- Air tool
- Temperature sensor
- CTS lubrication
- Oil mist/MQL
- Axial shaft displacement sensor
- Bearings temperature monitoring
- Speed monitoring
- Vibration sensor
- Sensor s5
- Taper cleaning

SPECIFICHE TECNICHE / TECHNICAL SPECIFICATIONS

- S1-S6 kW** 42/53
- S1-S6 Nm** 33,7/42
- rpm** 28000
- S1-S6 A** 120/148
- Volt** 380
- kg** 70
- Pol es** 6
- Supply** inverter

EQUIPAGGIAMENTO / EQUIPMENT

- HSK 63A
- Ceramic ball bearings
- Encoder TVpp
- Liquid cooling
- Labyrinth with air seal
- Oil lubrication
- Single effect hydraulic cylinder
- Sensors s1, s2
- Water tool cooling
- Automatic tool change (A.T.C)



STONETECH MG



-SUITABLE FOR MACHINING GLASS AND MARBLE AND STONE
POWER UP TO 30 KW AND HIGH TORQUES UP TO 39 NM
AVAILABLE WITH CASE AND CTS
ISO 40 TAPER

LAYOUT ISO 40

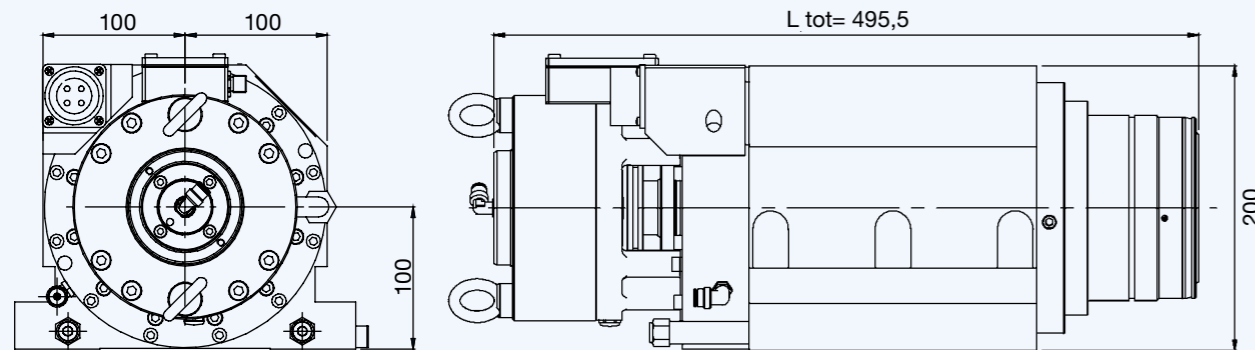

MG-2 9/6 15

PRESTAZIONI / PERFORMANCES

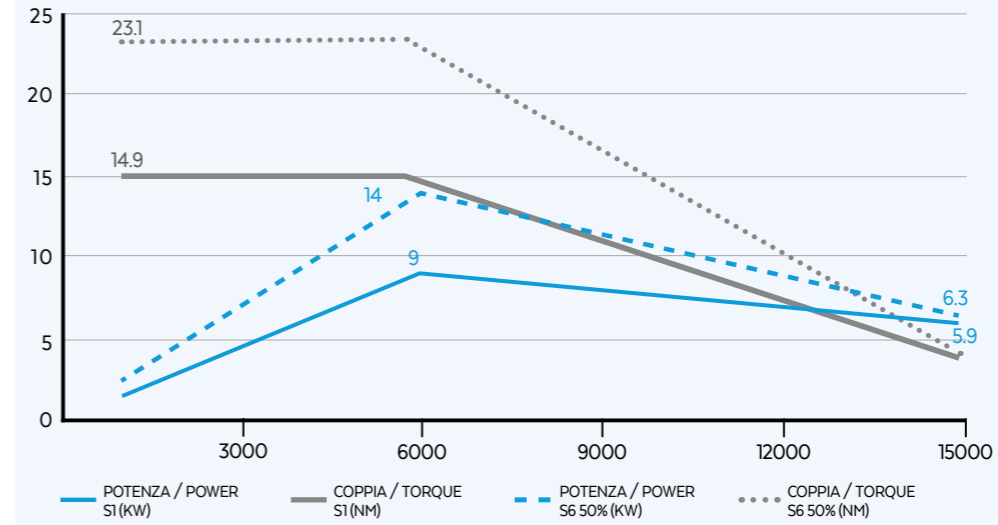

OPZIONALI / OPTIONS

- CTS lubrication
- Air tool
- Water tool cooling

SPECIFICHE TECNICHE / TECHNICAL SPECIFICATIONS

- S1-S6 kW** 9/14
- S1-S6 Nm** 14.9/23.1
- S1-S6 A** 24/33
- Volt** 380
- rpm** 15000
- kg** 90
- Pol es** 4
- Supply** inverter

EQUIPAGGIAMENTO / EQUIPMENT

- ISO 40
- Ceramic ball bearings
- Taper cleaning
- Liquid cooling
- Labyrinth with air seal
- Single effect cylinder
- Sensors s1, s2
- Automatic tool change (A.T.C)
- Grease lubrication

MG-2 13.5/6 15

PRESTAZIONI / PERFORMANCES

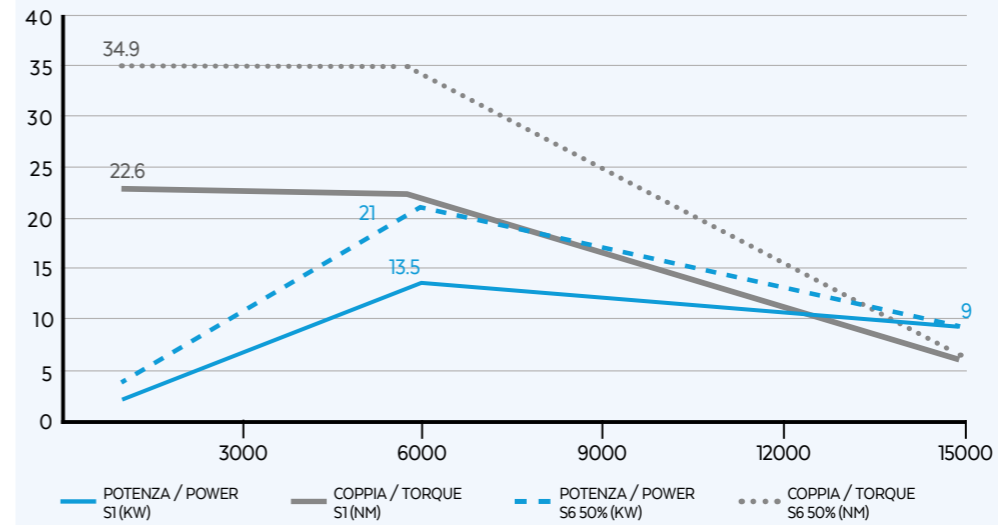

OPZIONALI / OPTIONS

- CTS lubrication
- Air tool
- Water tool cooling

SPECIFICHE TECNICHE / TECHNICAL SPECIFICATIONS

- S1-S6 kW** 13.5/21
- S1-S6 Nm** 22.6/34.9
- S1-S6 A** 32/34.9
- Volt** 380
- rpm** 15000
- kg** 90
- Pol es** 4
- Supply** inverter

EQUIPAGGIAMENTO / EQUIPMENT

- ISO 40
- Ceramic ball bearings
- Taper cleaning
- Liquid cooling
- Labyrinth with air seal
- Single effect cylinder
- Sensors s1, s2
- Automatic tool change (A.T.C)
- Grease lubrication

PRESTAZIONI / PERFORMANCES

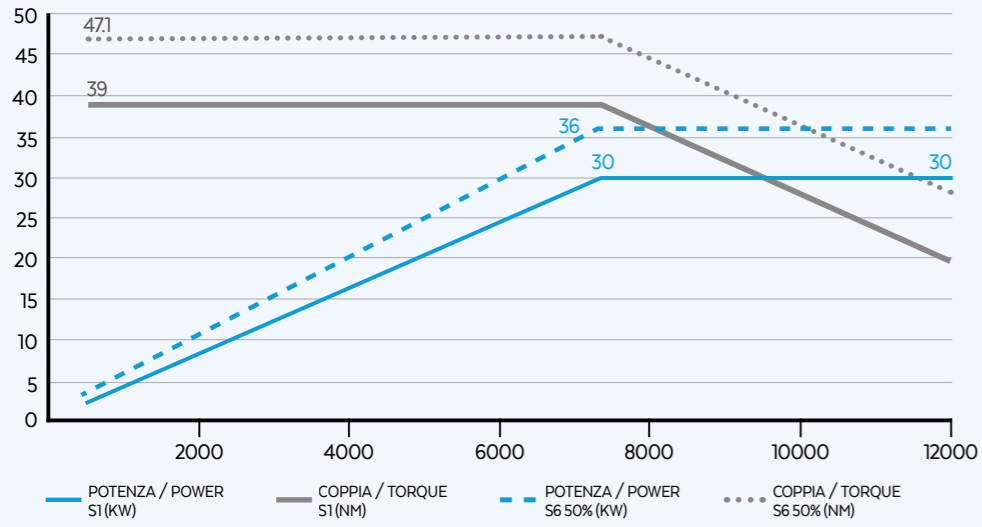

OPZIONALI / OPTIONS

- CTS Lubrication
- Air tool
- Water tool cooling

SPECIFICHE TECNICHE / TECHNICAL SPECIFICATIONS

- S1-S6 kW** 30/36
- S1-S6 A** 66/78
- Pol es** 4
- S1-S6 Nm** 39/47.1
- Volt** 380
- Supply** inverter
- rpm** 12000
- kg** 73

EQUIPAGGIAMENTO / EQUIPMENT

- ISO 40
- Liquid cooling
- Single effect cylinder
- Automatic tool change (A.T.C)
- Ceramic ball bearings
- Labyrinth with air seal
- Sensors s1, s2
- Grease lubrication
- Taper cleaning

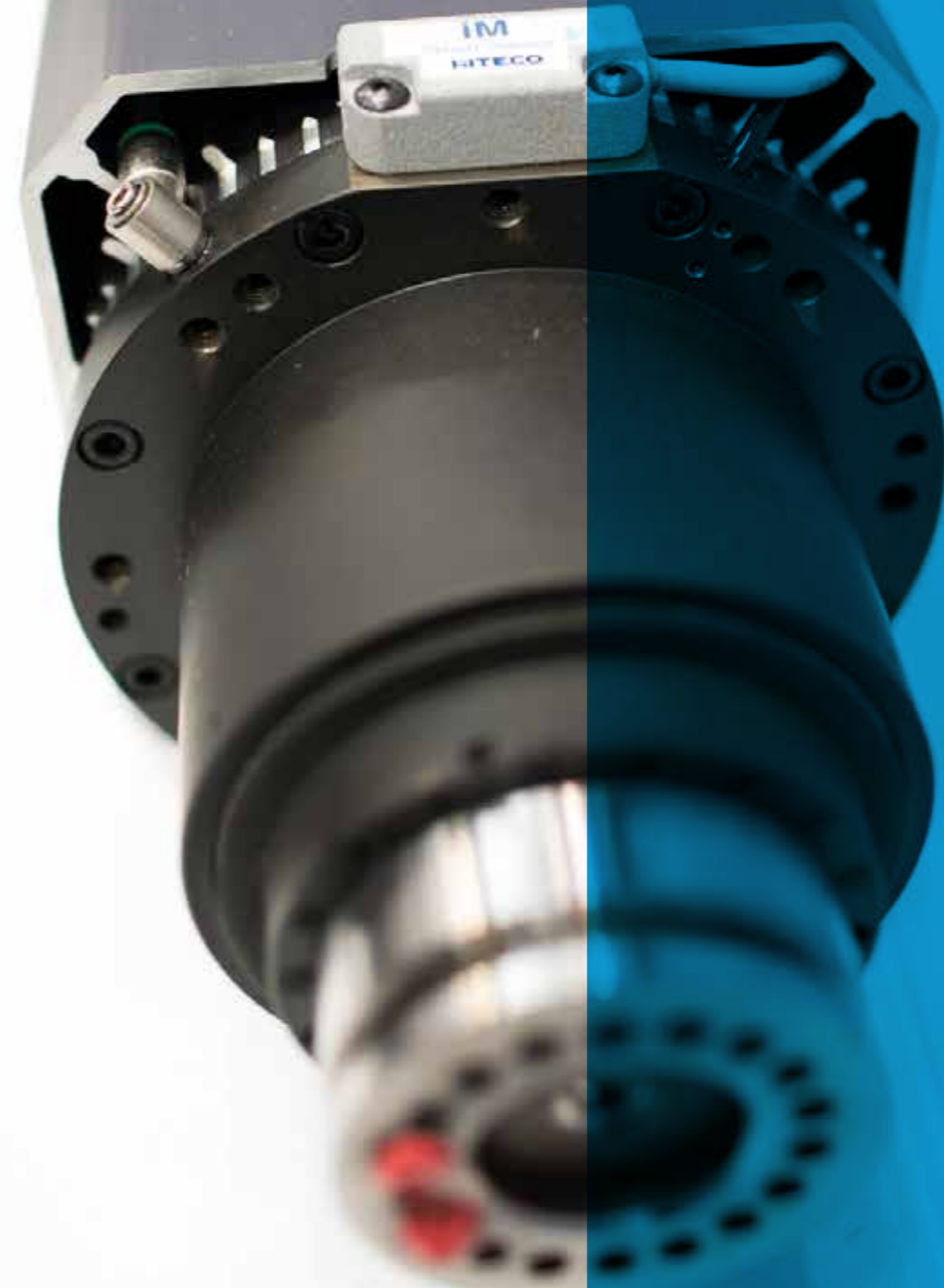

C-AXIS FOR POWERTECH 300-400



Compass Naso corto (NC) con 3 utenze pneumatiche, con servomotore Yaskawa
Compass Short Nose (NC) with 3 pneumatic connections With Yaskawa servo-motor

Compass Naso lungo (NL) con 3 utenze pneumatiche, con servomotore Yaskawa
Compass Long Nose (NL) with 3 pneumatic connections With Yaskawa servo-motor

OPZIONALI / OPTIONS

Disponibile senza servomotore
Available without servomotor

CONO PORTA UTENSILE TOOL HOLDER



Tool holder
Cono porta utensile HSK63F ER 32 M40X1.5_DX

Tool holder
Cono porta utensile ISO30 ER 32 M40X1.5_DX

Tool holder
Cono porta utensile HSK 63A ER 32 M40X1.5_DX

Per altre tipologie di pinze porta utensile, contatta lo staff Hiteco
For other tool holder types, please contact Hiteco staff

PINZA PORTA UTENSILE TOOL FINGER



Tool finger
Pinza porta utensile HSK 63F

Tool finger
Pinza porta utensile ISO 30

Tool finger
Pinza porta utensile HSK 63A

Per altre tipologie di pinze porta utensile, contatta lo staff Hiteco
For other tool finger sizes, please contact Hiteco staff

SCAMBIATORE DI CALORE HEAT EXCHANGER

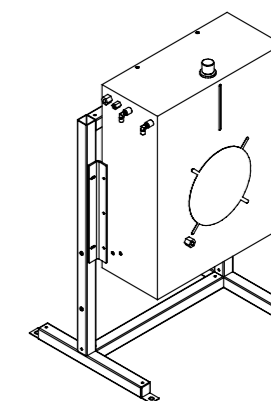

Potenza di raffreddamento
Cooling power 5000 W with liquid temperature +40°, air temperature +20°C

Portata liquido
Liquid flow 4 lt/min at 5,5 bar

Capacità serbatoio
Tank capacity 5 lt

OPZIONALI / OPTIONS

Disponibile versione senza supporto e tubi flessibili
Available without support and flexible hoses

RIFERIMENTO TESTINE ANTI-ROTATION SLEEVES



Riferimento testine per PT200: 2 posizioni, senza utenze pneumatiche
Anti-rotation sleeve for PT 200: 2 positions Without pneumatic connections

Riferimento testine per PT250: 2 posizioni, con o senza utenze pneumatiche
Anti-rotation sleeves for PT 250: 2 positions With or without pneumatic connections

Riferimento testine per PT300-400: 2 posizioni, disponibile in versione Naso corto e Naso lungo (NC e NL), con e senza utenze pneumatiche
Anti-rotation sleeves for PT 300-400: 2 positions Available with Short and Long Nose (NC and NL) With or without pneumatic connections

Riferimento testine per mandrini 5 assi (con 1 utenza pneumatica)
Anti-rotation sleeves for 5-axis spindles With 1 pneumatic connection

