

**ATTACCO HSK 100A**  
**TOOL INTERFACE HSK 100A**  
**ISO 12164-1/DIN69893-1**

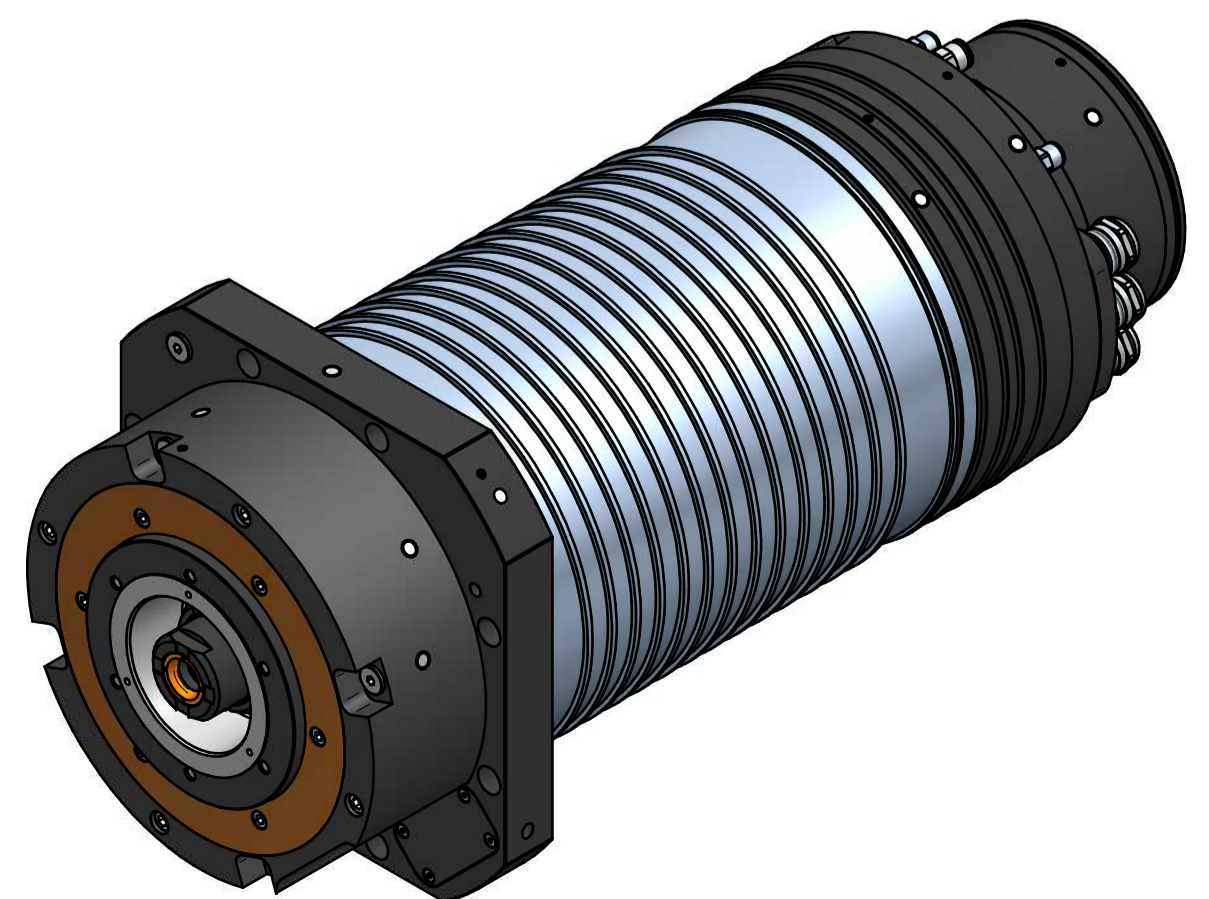
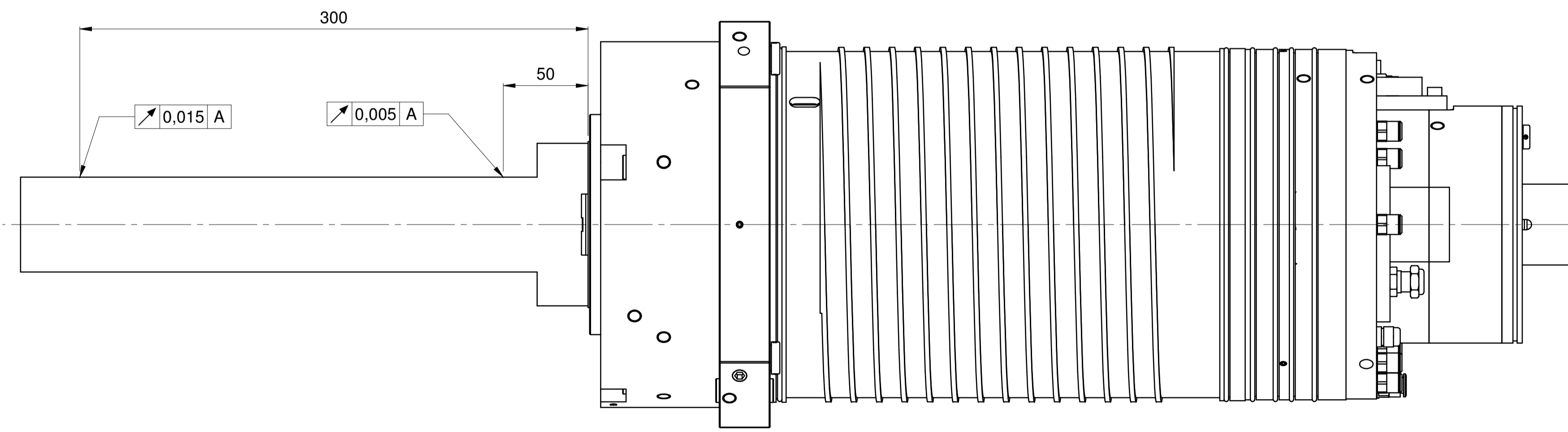

<b>SCHEMA REGOLAZIONE SENSORI: 90L0601628A</b>			
<b>SCHEMA ELETTRICO- PNEUMATICO: 90L0601627H</b>			
Firma / Signature	Data / Date		
Controlato / Checked by	Data / Date	Firma / Signature	N° Modifica / Change ID
Disegnato / Designed by	Descrizione ultima modifica / Last change description		
Denominazione / Item Name			
<b>ELETM MX-2 47/3 15 O 100A ES</b>			
Scala / Scale	Codice / Item ID	Rev	Status
	<b>29L0601604B</b>	<b>00</b>	<b>3/3</b>

**HITECO**  
HIGH TECHNOLOGY COMPONENTS

© HITECO S.p.A. TUTTI I DIRITTI RISERVATI. È vietata espressamente la ristampa o l'uso non autorizzato senza permesso scritto dalla HITECO S.p.A. / ALL RIGHTS RESERVED. ANY UNAUTHORIZED REPRODUCTION OR USE WITHOUT THE WRITTEN PERMISSION OF HITECO S.p.A. IS EXPRESSLY FORBIDDEN.