

双向旋转头  
BIROTARY UNITS



# 适用于机床制造商的高科技部件

**High-tech components** for machine tool manufacturers.

Hiteco专业设计和制造机床领域使用的高科技工业机电部件。  
**A.T.C电主轴，M.T.C电主轴，双向旋转头，钻头和总成。**

Hiteco is specialized in design and manufacture of high technology industrial electromechanical components for machine tools. **A.T.C. electrospindles, M.T.C. electrospindles, birotary heads, boring units and aggregates.**



Hiteco向国际市场推出系列广泛的产品用于加工：**木材，塑料，高级材料，玻璃，石材和金属。**

Hiteco offers a wide range of products on international market for **wood, plastic, advanced materials, glass, stone and metal processing.**



Hiteco诞生于1977年，是各类材料加工机床制造领域全球领导者**SCM集团**旗下的一个分部，自此开始了其指数级的成长之路。2008年，Hiteco成为了**为外部客户市场提供服务的利润中心**。如今其所生产的产品已经成为市场的标杆，是专业领域中最重要全球巨头之一。

Hiteco founded in 1977 as an internal division of the **SCM Group**, leading company in machine tools construction for processing a wide range of materials, had an increasingly exponential growth. In 2008 it become **a profit unit for external customers**. Today Hiteco offers key products for the components market, becoming one of the most important world players in the sector.



## 销售网络遍布全球，提供一流的服务

**A capillary presence for a best-in-class and worldwide service.**

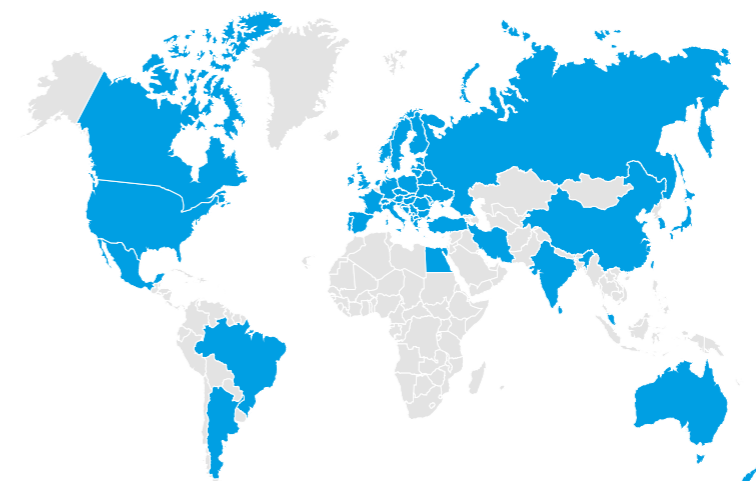

分布广泛的网络满足了Hiteco与客户保持密切联系的需求，在各地派驻了**专业的技术人员**，保证了极其快速而专业的反应能力：不仅可以降低停机次数和减少生产中出现的问题，而且通过提出有效和创新的解决方案来创造附加值。这一优势不仅缩短了交货的时间，也是Hiteco在国际市场上赢得最高**客户满意度**的原因之一。

**The widespread distribution** of the company responds to the desire of Hiteco to be close to the customer with the presence of **specialized technicians** on the territory who guarantee an extremely rapid and professional response: not only to reduce machine downtimes and production problems, but also to create added value with the proposal of effective and innovative solutions. Such care, in addition to reduced delivery times, is one of the reason that led Hiteco to have the highest **customer satisfaction** on the international market.





# 目录

## INDEX



### p.6 系列 **ORBITAL (50°)**

木材和先进材料 / Wood and advanced materials

- p. 6 Orbital J
- p. 8 Orbital J HIGH SPEED
- p. 10 Orbital K
- p. 12 Orbital H

### p.14 系列 **TILT (90°)**

先进材料、轻合金、塑料和木材 / Advanced materials, light alloys, plastic and wood

- p. 14 Tilt J
- p. 16 Tilt J HIGH SPEED
- p. 18 Tilt K
- p. 20 Tilt K PLUS
- p. 22 Tilt H
- p. 24 Tilt H PLUS
- p. 26 Tilt V
- p. 28 Tilt V QT
- p. 30 Tilt W
- p. 32 Tilt TLP

技术数据和插图不具约束力，为确保产品和服务的持续拓展，HITECO保留作出修改的权利，恕不另行通知。

Technical data and illustrations are not binding and, for the constant development of products and services, HITECO reserves the right to make modifications without prior notice.

WOOD

PLASTIC

ADVANCED  
MATERIALS

LIGHT  
ALLOYS

# 系列 ORBITAL ORBITAL J

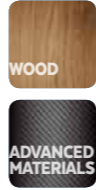

AVAILABLE WITH



## LAYOUT

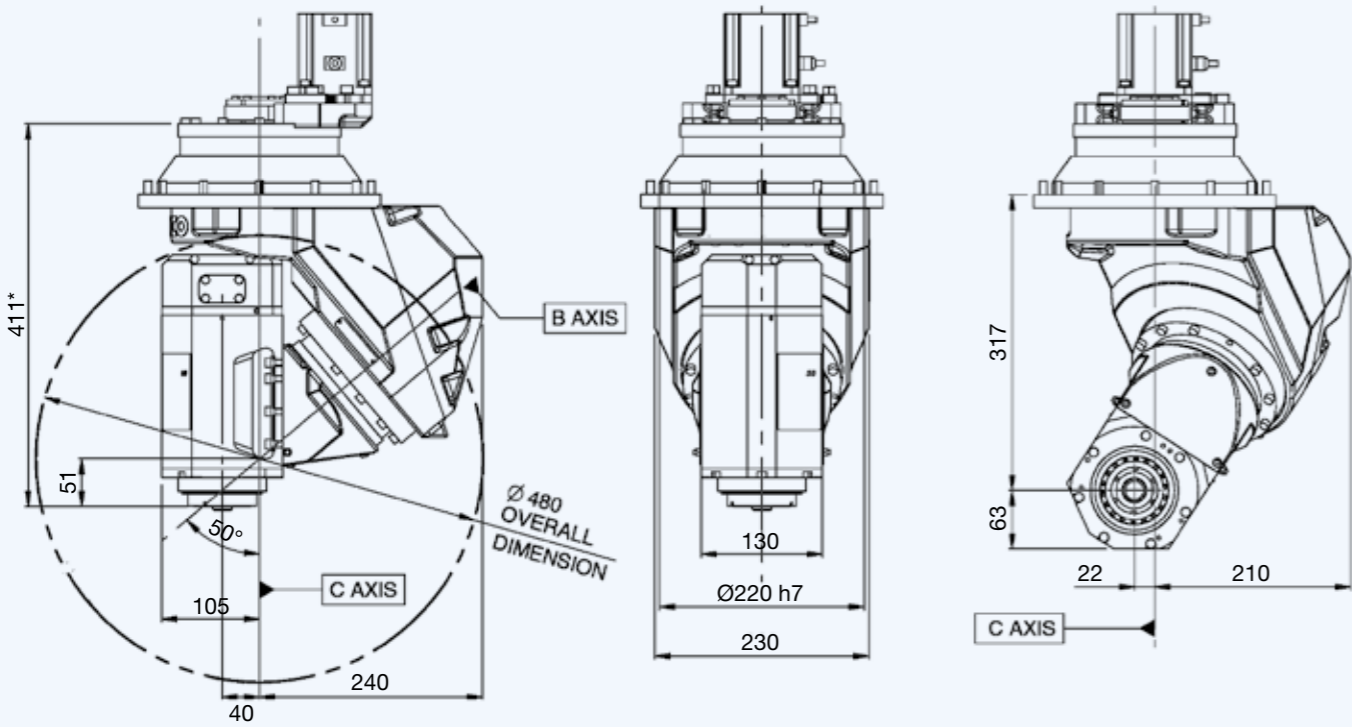

## 电主轴选择 / ELECTROSPINDLE OPTIONS

- 轴承温度监控 / Temperature monitoring of bearings
- 测速仪 / Speed monitoring
- 震动传感器 / Vibration sensor
- Encoder\*

\* 可选编码器比表中所示的值大25 mm  
\* When the unit is with encoder the quote increases by 25 mm from the one represented in the plan

## 技术规格 / TECHNICAL SPECIFICATIONS

\* 可按需求提供其他品牌的马达  
\* Other engine brands are available on demand

	B轴 / B AXIS	C轴 / C AXIS
伺服电机 / Servomotor	Yaskawa*	Yaskawa*
伺服电机功率 / Servomotor power	0,4 kW	0,4 kW
伺服电机编码器 / Servomotor encoder	绝对式 Absolute 20 Bit	绝对式 Absolute 20 Bit
齿轮箱 / Gearbox	Harmonic Drive	Harmonic Drive
最大连续扭矩 / Max. continuous torque	320 Nm	320 Nm
峰值扭矩 / Peak torque	570 Nm	570 Nm
轴最大转角 / Max axis rotation	$\pm 185^\circ$	$\pm 320^\circ$
机械制动 / Mechanical blocking of axes	No	No
最大定位速度 / Max. positioning speed	7.000°/'	7.000°/'
最大工作速度 / Max operating speed	4.000°/'	4.000°/'
轴定位精度 / Axis positioning accuracy	1 arcmin	1 arcmin
重量 / Weight		55 kg

## 可用电主轴 / AVAILABLE ELECTROSPINDLES

QX-2 8.5/12 24 63F NC

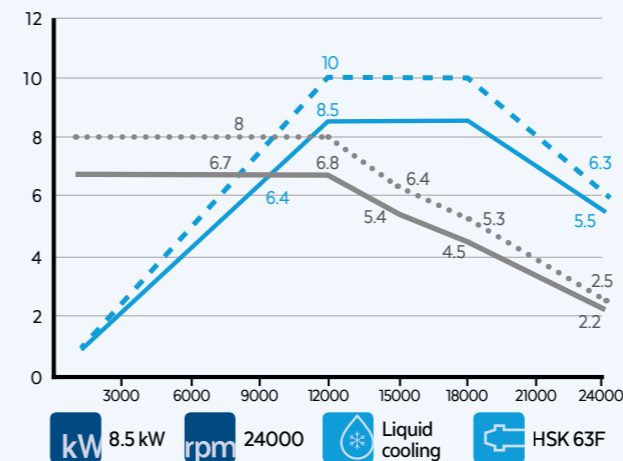

QX-2 10/12 24 63F NC

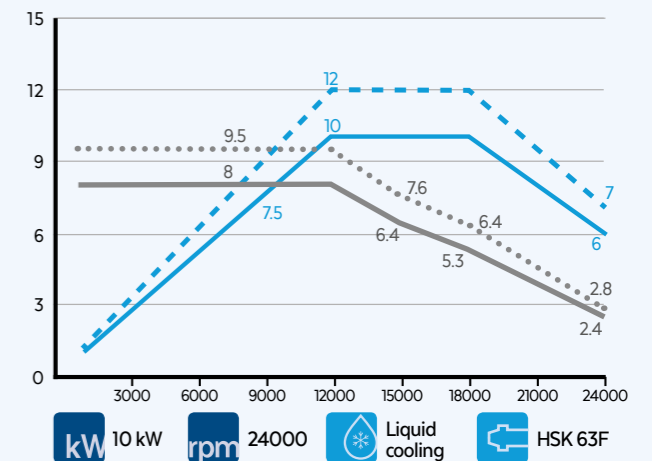

QX-2 11/12 24 63F NC

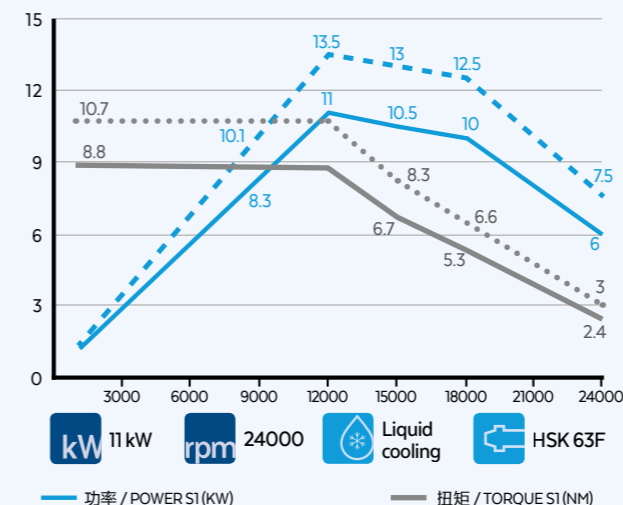

QX-1C 5/12 21 63F NC

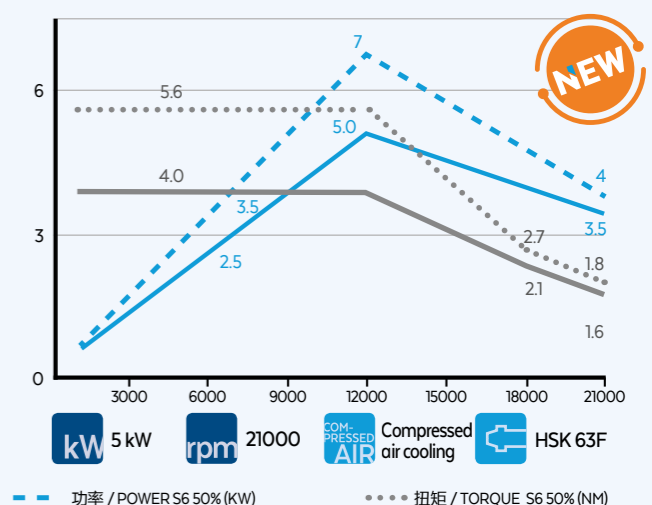



# 系列 ORBITAL ORBITAL J HIGH SPEED



AVAILABLE WITH



## LAYOUT

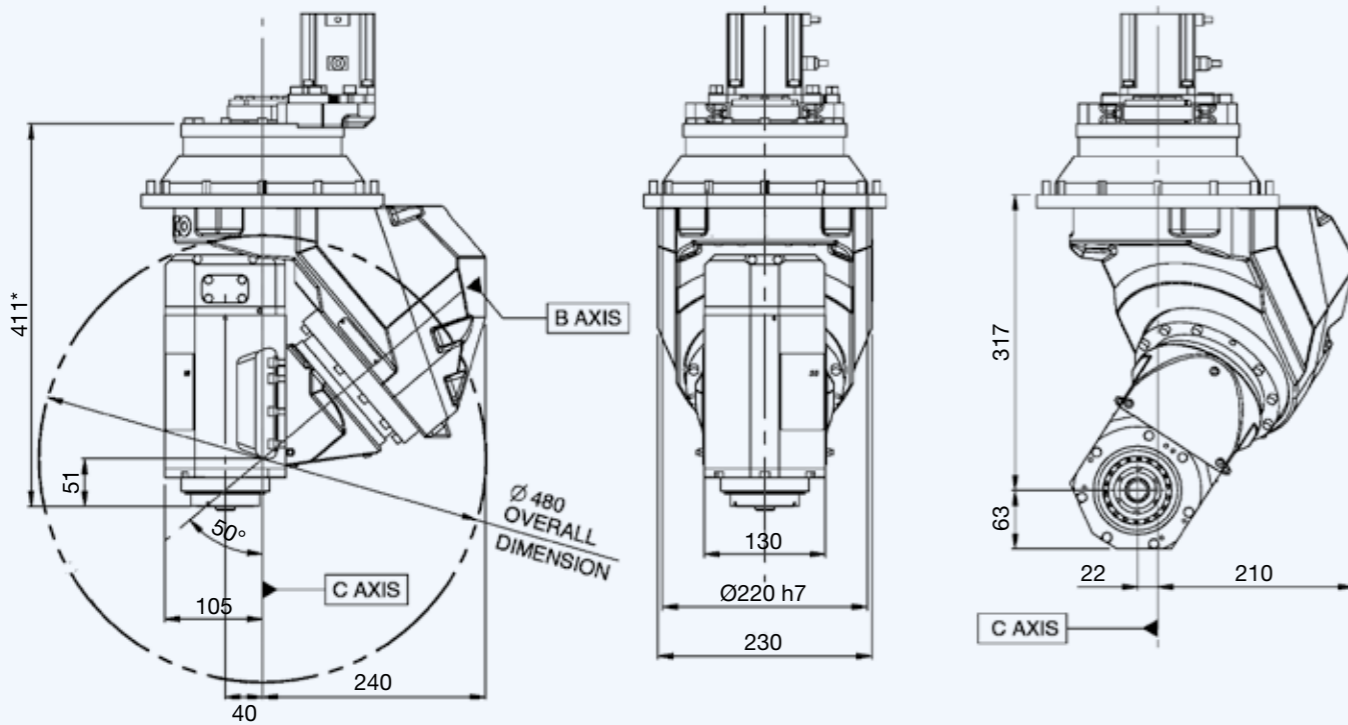

## 电主轴选择 / ELECTROSPINDLE OPTIONS

- 轴承温度监控 / Temperature monitoring of bearings
- 测速仪 / Speed monitoring
- 震动传感器 / Vibration sensor
- Encoder\*

\* 可选编码器比表中所示的值大25 mm  
\* When the unit is with encoder the quote increases by 25 mm from the one represented in the plan

## 技术规格 / TECHNICAL SPECIFICATIONS

\* 可按需求提供其他品牌的马达  
\* Other engine brands are available on demand

	B轴 / B AXIS	C轴 / C AXIS
伺服电机 / Servomotor	Yaskawa*	Yaskawa*
伺服电机功率 / Servomotor power	0,4 kW	0,4 kW
伺服电机编码器 / Servomotor encoder	绝对式 Absolute 20 Bit	绝对式 Absolute 20 Bit
齿轮箱 / Gearbox	Harmonic Drive	Harmonic Drive
最大连续扭矩 / Max. continuous torque	320 Nm	320 Nm
峰值扭矩 / Peak torque	570 Nm	570 Nm
轴最大转角 / Max axis rotation	±185°	±320°
机械制动 / Mechanical blocking of axes	No	No
最大定位速度 / Max. positioning speed	7.000°/'	7.000°/'
最大工作速度 / Max operating speed	4.000°/'	4.000°/'
轴定位精度 / Axis positioning accuracy	1 arcmin	1 arcmin
重量 / Weight		55 kg

## 可用电主轴 / AVAILABLE ELECTROSPINDLES

QX-2 8/15 36 40E NC

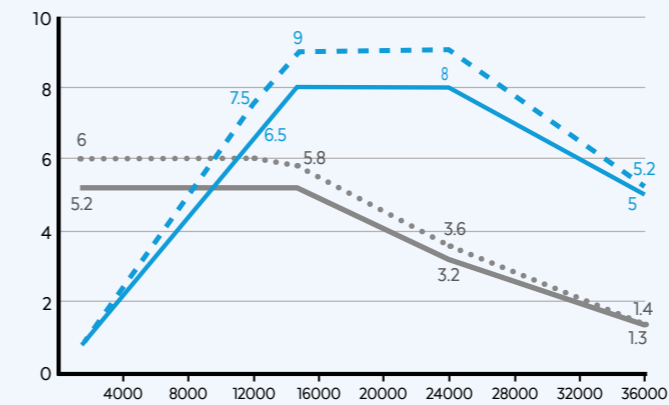

**kW** 8 kW **rpm** 36000 Liquid cooling HSK 40E

QX-2 8/15 40 32E NC

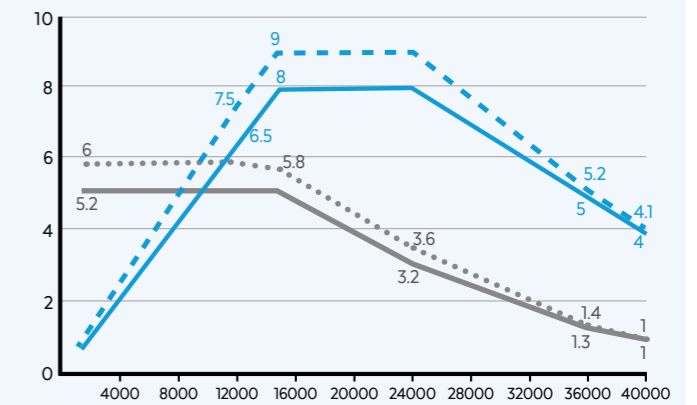

**kW** 8 kW **rpm** 40000 Liquid cooling HSK 32E

— 功率 / POWER S1 (KW)      — 扭矩 / TORQUE S1 (NM)      - - - 功率 / POWER S6 50% (KW)      ···· 扭矩 / TORQUE S6 50% (NM)

# 系列 ORBITAL ORBITAL K

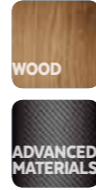

AVAILABLE WITH



## LAYOUT

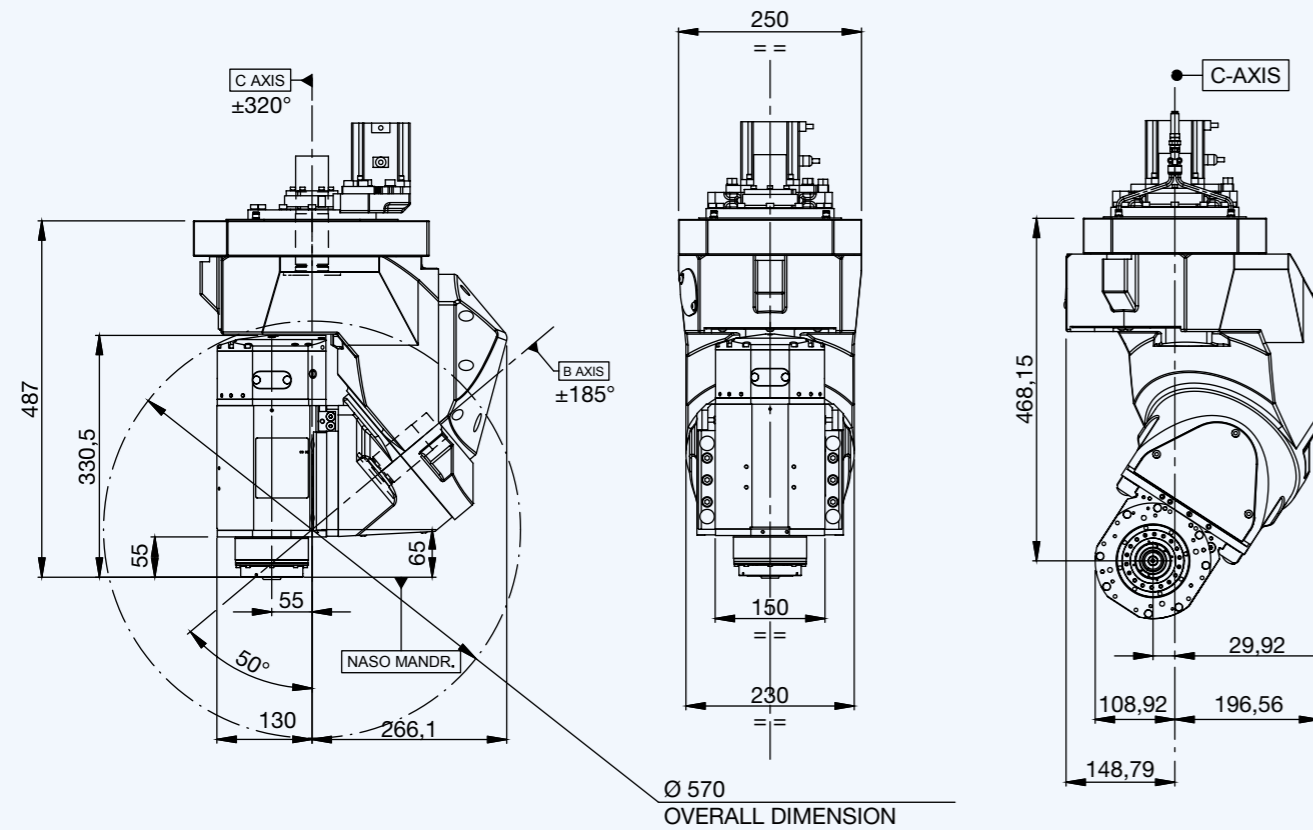

## 电主轴选择 / ELECTROSPINDLE OPTIONS

- 长鼻  
Long nose
- HSK 63E
- HSK 63A
- 轴承温度监控  
Temperature monitoring of bearings
- 测速仪  
Speed monitoring
- 震动传感器  
Vibration sensor
- Encoder

## 技术规格 / TECHNICAL SPECIFICATIONS

\* 可按需求提供其他品牌的马达  
\*Other engine brands are available on demand

	B轴 / B AXIS	C轴 / C AXIS
伺服电机 / Servomotor	Yaskawa*	Yaskawa*
伺服电机功率 / Servomotor power	0,4 kW	0,4 kW
伺服电机编码器 / Servomotor encoder	绝对式 Absolute 20 Bit	绝对式 Absolute 20 Bit
齿轮箱 / Gearbox	Harmonic Drive	Harmonic Drive
最大连续扭矩 / Max. continuous torque	320 Nm	320 Nm
峰值扭矩 / Peak torque	570 Nm	570 Nm
轴最大转角 / Max axis rotation	±185°	±320°
机械制动 / Mechanical blocking of axes	No	是 Yes
最大定位速度 / Max. positioning speed	7.000°/'	7.000°/'
最大工作速度 / Max operating speed	4.000°/'	4.000°/'
轴定位精度 / Axis positioning accuracy	1 arcmin	1 arcmin
重量 / Weight		100 kg

## 可用电主轴 / AVAILABLE ELECTROSPINDLES

PX-2 10/7 24 63F NC

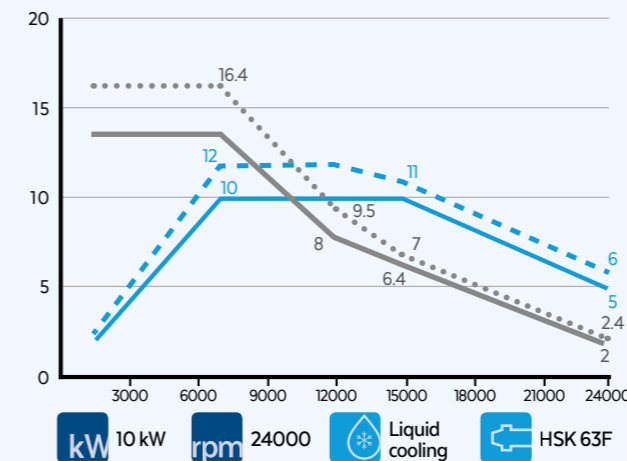

PX-2 12/12 24 63F NC

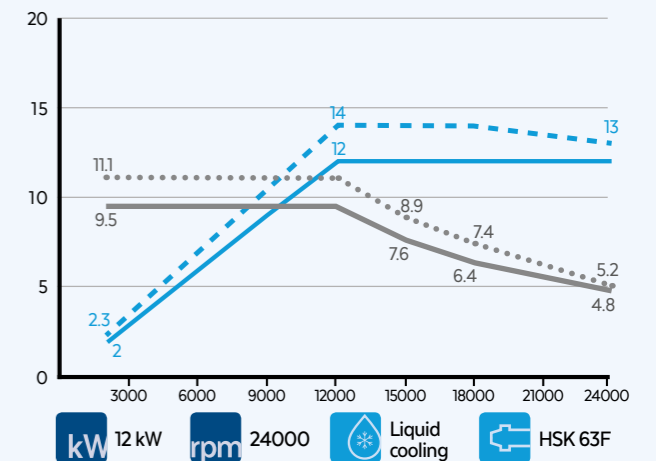

PX-2 15/12 24 63F NC

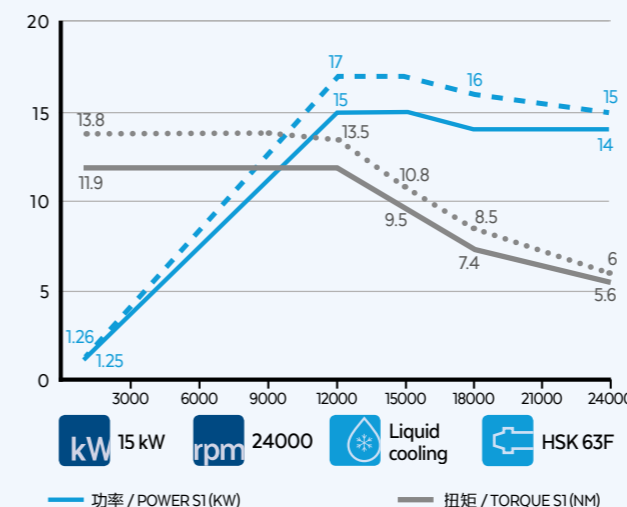

# 系列 ORBITAL ORBITAL H

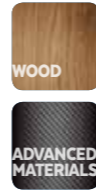

AVAILABLE WITH



## LAYOUT

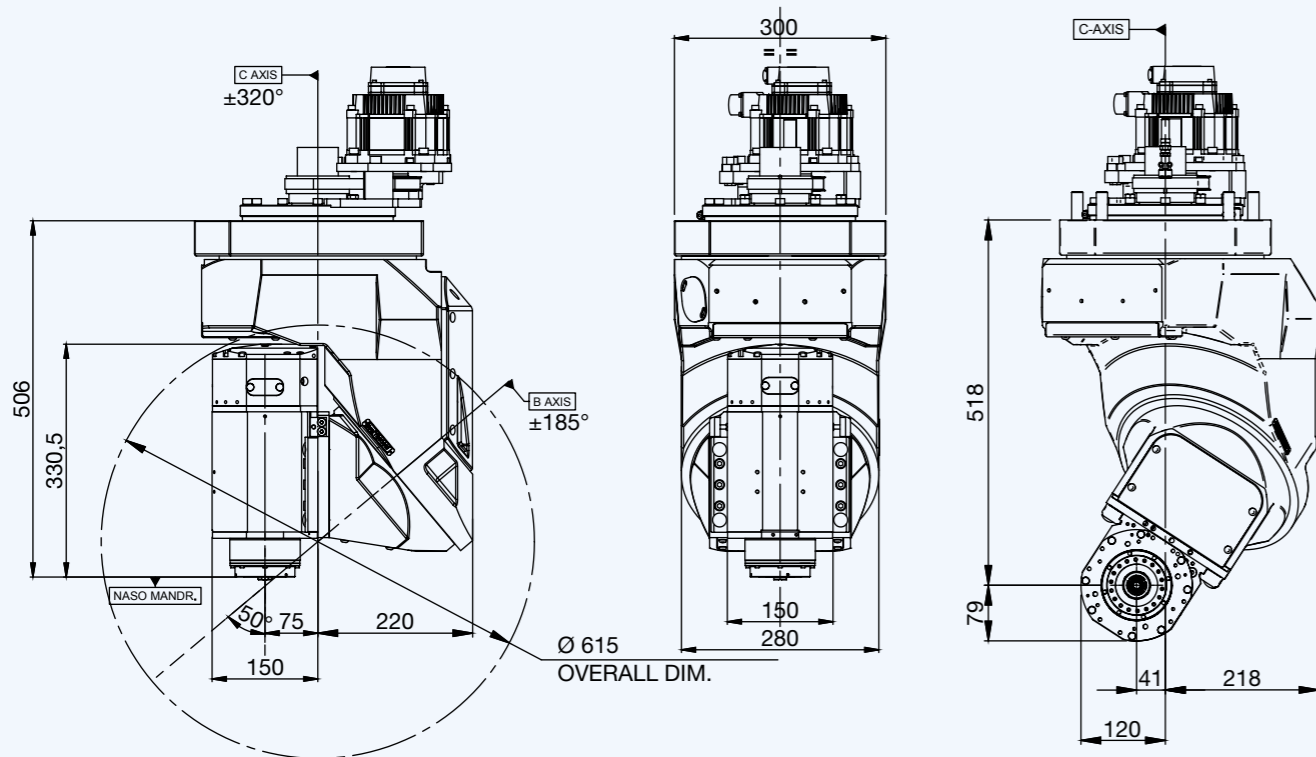

## 电主轴选择 / ELECTROSPINDLE OPTIONS

- 长鼻 / Long nose
- HSK 63E
- HSK 63A (Standard on 20 kW)
- 轴承温度监控 / Temperature monitoring of bearings
- 测速仪 / Speed monitoring
- 震动传感器 / Vibration sensor
- Encoder

## 技术规格 / TECHNICAL SPECIFICATIONS

\* 可按需求提供其他品牌的马达  
\* Other engine brands are available on demand

	B轴 / B AXIS	C轴 / C AXIS
伺服电机 / Servomotor	Yaskawa*	Yaskawa*
伺服电机功率 / Servomotor power	0,75 kW	0,85 kW
伺服电机编码器 / Servomotor encoder	绝对式 Absolute 20 Bit	绝对式 Absolute 20 Bit
齿轮箱 / Gearbox	Sumitomo	Harmonic Drive
最大连续扭矩 / Max. continuous torque	320 Nm	670 Nm
峰值扭矩 / Peak torque	740 Nm	980 Nm
轴最大转角 / Max axis rotation	$\pm 185^\circ$	$\pm 320^\circ$
机械制动 / Mechanical blocking of axes	是 Yes	是 Yes
最大定位速度 / Max. positioning speed	10.000°/'	11.500°/'
最大工作速度 / Max operating speed	4.500°/'	5.500°/'
轴定位精度 / Axis positioning accuracy	1 arcmin	1 arcmin
重量 / Weight		140 kg

## 可用电主轴 / AVAILABLE ELECTROSPINDLES

PX-2 10/7 24 63F NC

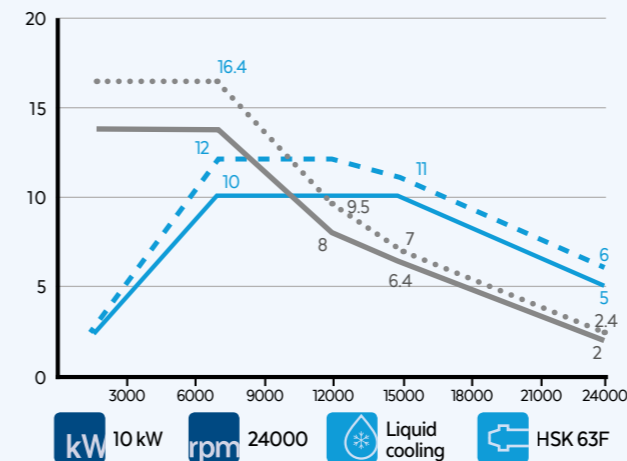

PX-2 15/12 24 63F NC

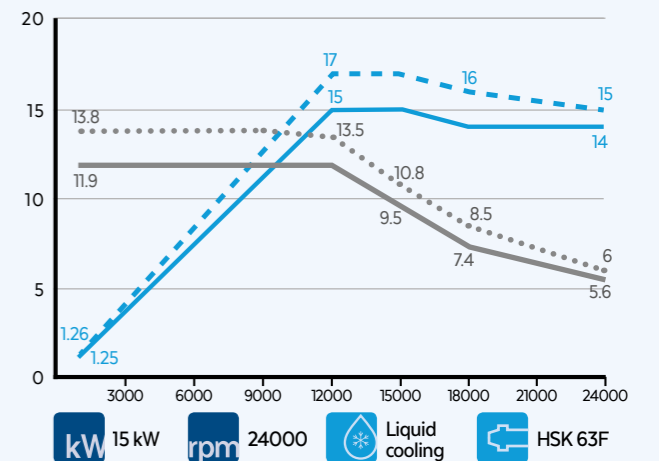

PX-2 18/12 24 63F NC

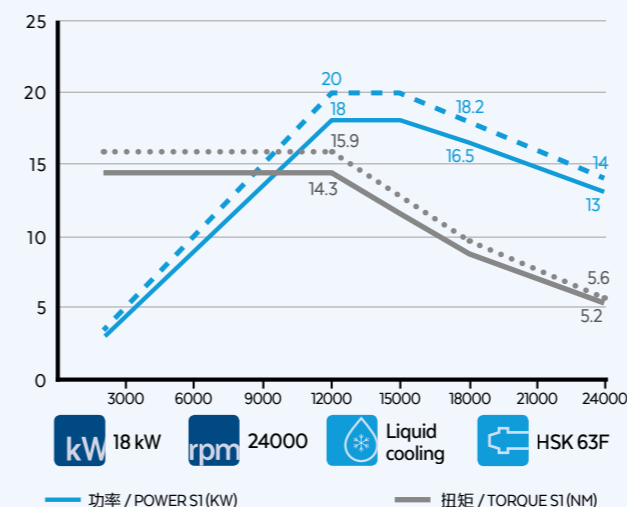

PX-2 20/10 24 63A NC ES SYNCHRONOUS

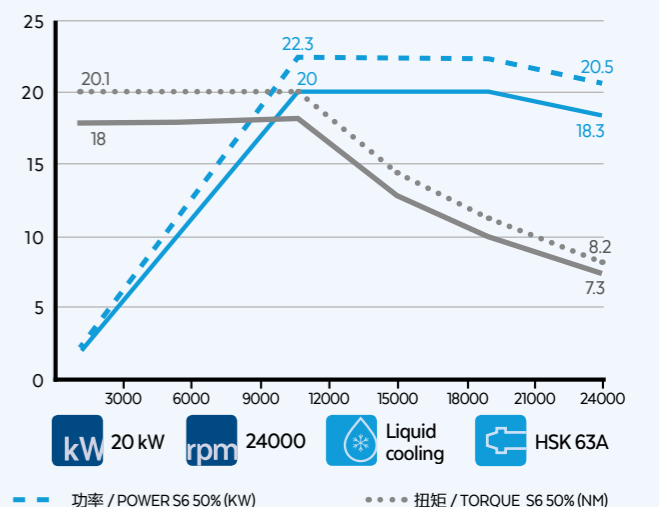

# 系列 TILT TILT J



AVAILABLE WITH



## 技术规格 / TECHNICAL SPECIFICATIONS

\* 可按需求提供其他品牌的马达  
\* Other engine brands are available on demand

	ASSE A / A AXIS	C轴 / C AXIS
伺服电机 / Servomotor	Yaskawa*	Yaskawa*
伺服电机功率 / Servomotor power	0,40 kW	0,40 kW
伺服电机编码器 / Servomotor encoder	绝对式 Absolute 20 Bit	绝对式 Absolute 20 Bit
齿轮箱 / Gearbox	Harmonic Drive	Harmonic Drive
最大连续扭矩 / Max. continuous torque	380 Nm	380 Nm
峰值扭矩 / Peak torque	570 Nm	570 Nm
轴最大转角 / Max axis rotation	±120°	±320°
机械制动 / Mechanical blocking of axes	No	No
最大定位速度 / Max. positioning speed	6.100°/'	6.100°/'
最大工作速度 / Max operating speed	3.700°/'	3.700°/'
轴定位精度 / Axis positioning accuracy	1 arcmin	1 arcmin
重量 / Weight		60 kg

## LAYOUT

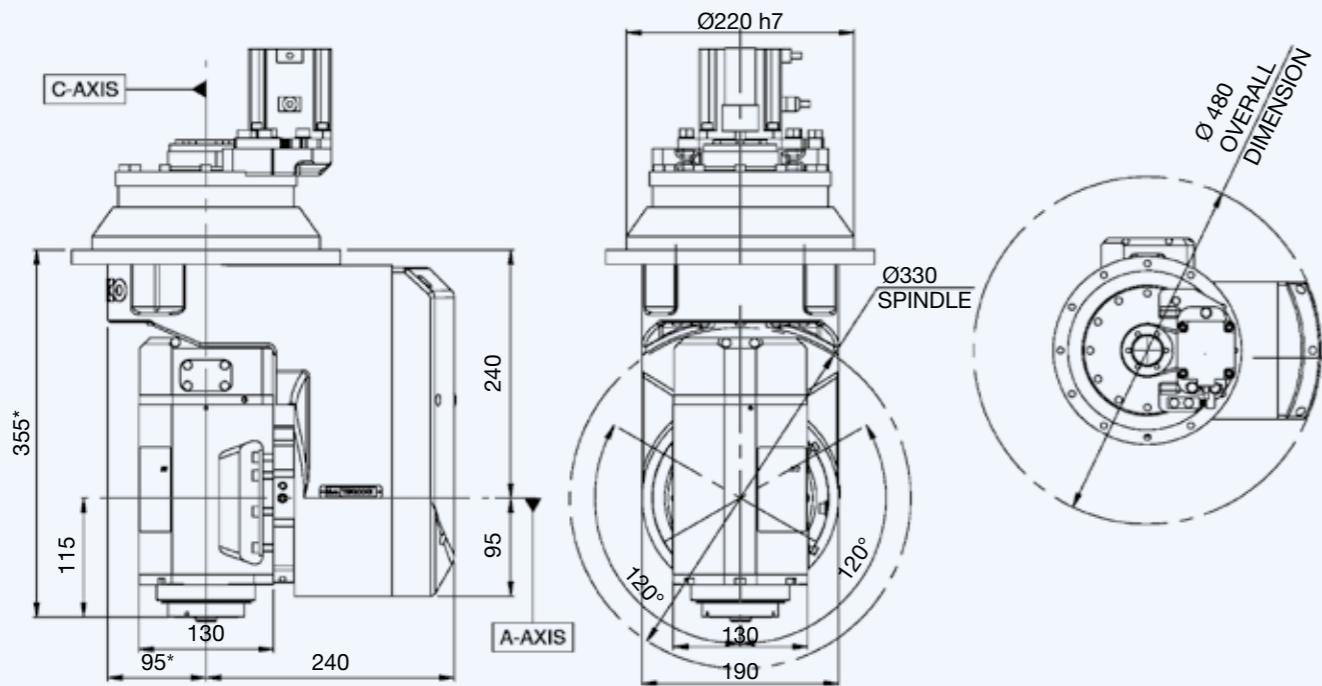

## 电主轴选择 / ELECTROSPINDLE OPTIONS

- 轴承温度监控 / Temperature monitoring of bearings
- 测速仪 / Speed monitoring
- 震动传感器 / Vibration sensor
- Encoder\*

\* 可选编码器比表中所示的值大25 mm  
\* When the unit is with encoder the quote increases by 25 mm from the one represented in the plan

## 可用电主轴 / AVAILABLE ELECTROSPINDLES

QX-2 8.5/12 24 63F NC

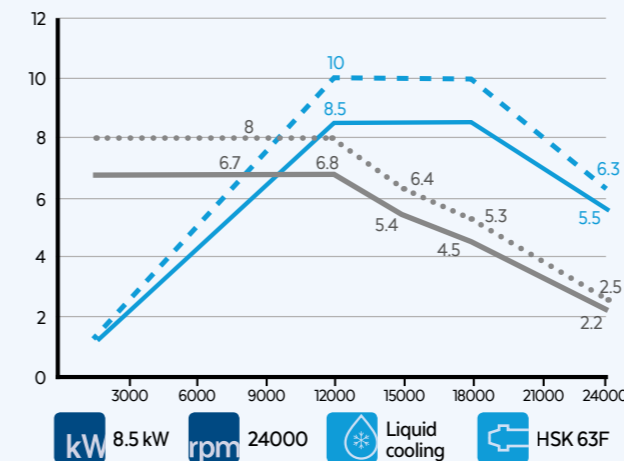

QX-2 10/12 24 63F NC

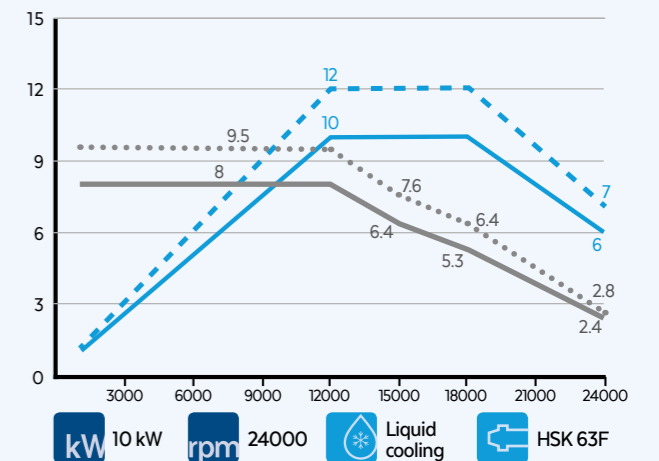

QX-2 11/12 24 63F NC

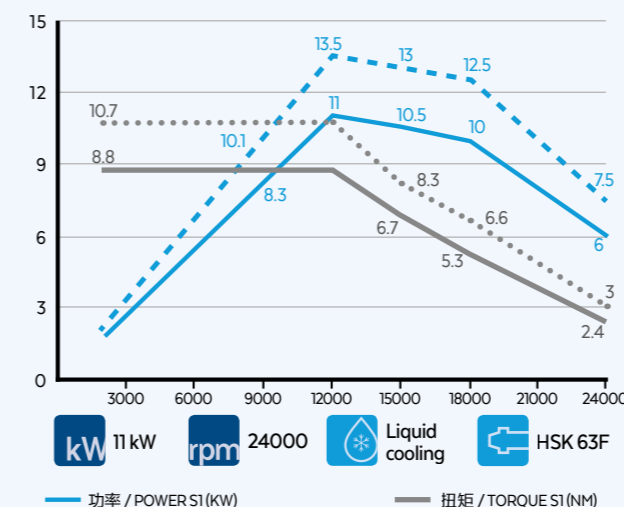

QX-1C 5/12 21 63F NC

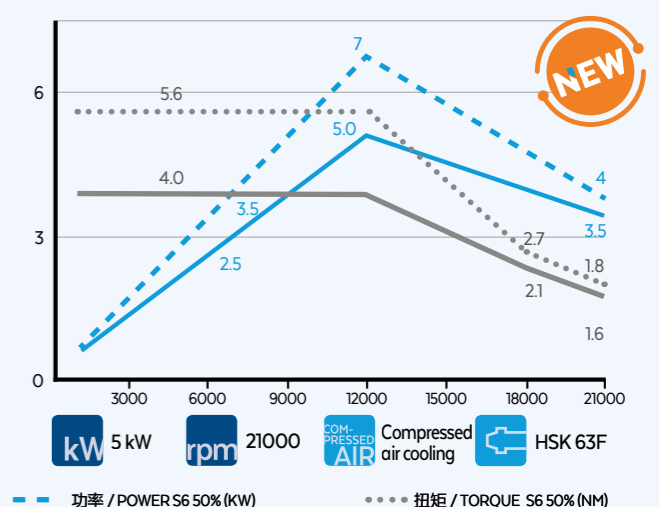



# 系列 TILT TILT J HIGH SPEED



AVAILABLE WITH



## LAYOUT

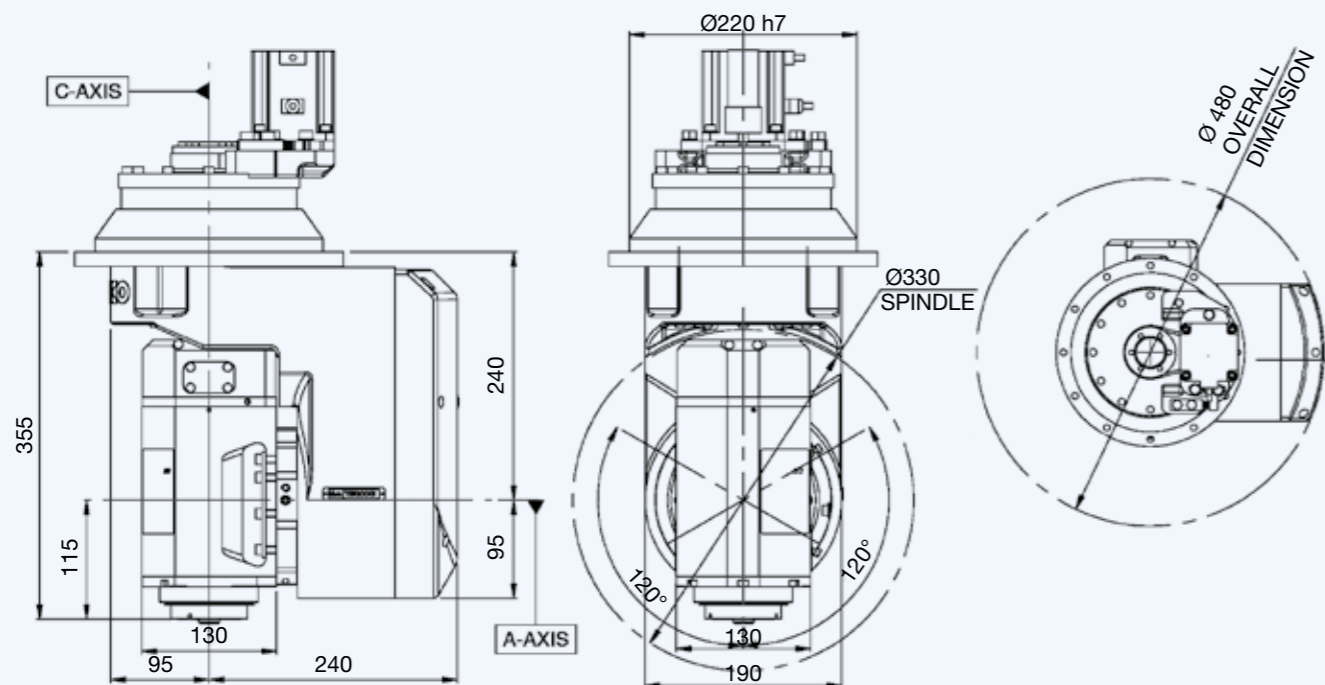

## 电主轴选择 / ELECTROSPINDLE OPTIONS

- 轴承温度监控 / Temperature monitoring of bearings
- 测速仪 / Speed monitoring
- 震动传感器 / Vibration sensor
- Encoder

## 技术规格 / TECHNICAL SPECIFICATIONS

\* 可按需求提供其他品牌的马达  
\* Other engine brands are available on demand

	ASSE A / A AXIS	C轴 / C AXIS
伺服电机 / Servomotor	Yaskawa*	Yaskawa*
伺服电机功率 / Servomotor power	0,40 kW	0,40 kW
伺服电机编码器 / Servomotor encoder	绝对式 Absolute 20 Bit	绝对式 Absolute 20 Bit
齿轮箱 / Gearbox	Harmonic Drive	Harmonic Drive
最大连续扭矩 / Max. continuous torque	380 Nm	380 Nm
峰值扭矩 / Peak torque	570 Nm	570 Nm
轴最大转角 / Max axis rotation	$\pm 120^\circ$	$\pm 320^\circ$
机械制动 / Mechanical blocking of axes	No	No
最大定位速度 / Max. positioning speed	$6.100^\circ/'$	$6.100^\circ/'$
最大工作速度 / Max operating speed	$3.700^\circ/'$	$3.700^\circ/'$
轴定位精度 / Axis positioning accuracy	1 arcmin	1 arcmin
重量 / Weight		60 kg

## 可用电主轴 / AVAILABLE ELECTROSPINDLES

QX-2 8/15 36 40E NC

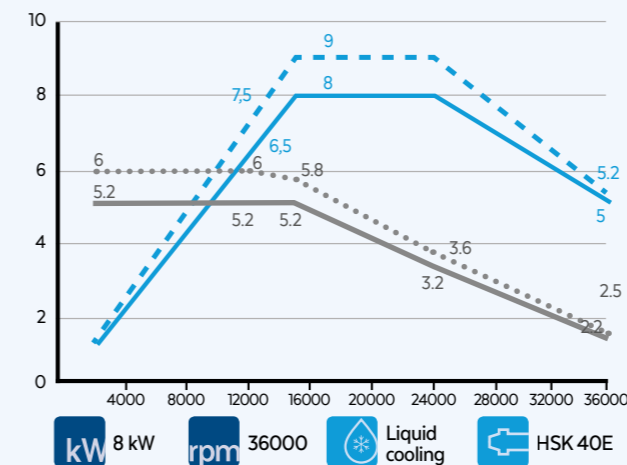

QX-2 8/15 40 32E NC

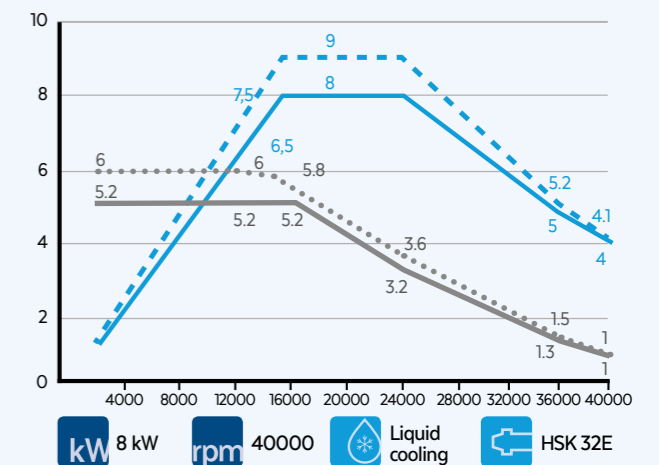

— 功率 / POWER S1 (KW)      — 扭矩 / TORQUE S1 (NM)      - - - 功率 / POWER S6 50% (KW)      ···· 扭矩 / TORQUE S6 50% (NM)

# 系列 TILT TILT K



AVAILABLE WITH



## LAYOUT

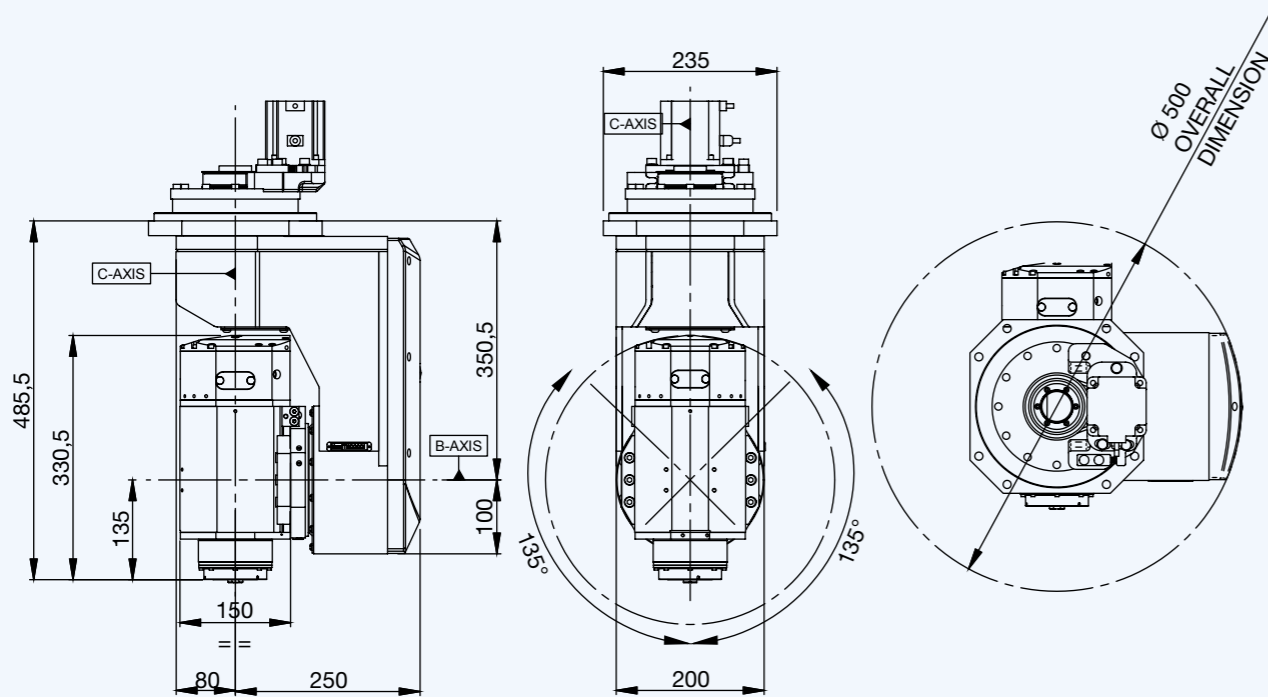

## 电主轴选择 / ELECTROSPINDLE OPTIONS

- 长鼻 / Long nose
- HSK 63E
- HSK 63A
- 轴承温度监控 / Temperature monitoring of bearings
- 测速仪 / Speed monitoring
- 震动传感器 / Vibration sensor
- Encoder

## 技术规格 / TECHNICAL SPECIFICATIONS

\* 可按需求提供其他品牌的马达  
\* Other engine brands are available on demand

	ASSE A / A AXIS	C轴 / C AXIS
伺服电机 / Servomotor	Yaskawa*	Yaskawa*
伺服电机功率 / Servomotor power	0,40 kW	0,40 kW
伺服电机编码器 / Servomotor encoder	绝对式 Absolute 20 Bit	绝对式 Absolute 20 Bit
齿轮箱 / Gearbox	Harmonic Drive	Harmonic Drive
最大连续扭矩 / Max. continuous torque	380 Nm	380 Nm
峰值扭矩 / Peak torque	570 Nm	570 Nm
轴最大转角 / Max axis rotation	±135°	±320°
机械制动 / Mechanical blocking of axes	No	No
最大定位速度 / Max. positioning speed	6.100°/'	6.100°/'
最大工作速度 / Max operating speed	3.700°/'	3.700°/'
轴定位精度 / Axis positioning accuracy	1 arcmin	1 arcmin
重量 / Weight		100 kg

## 可用电主轴 / AVAILABLE ELECTROSPINDLES

PX-2 10/7 24 63F NC

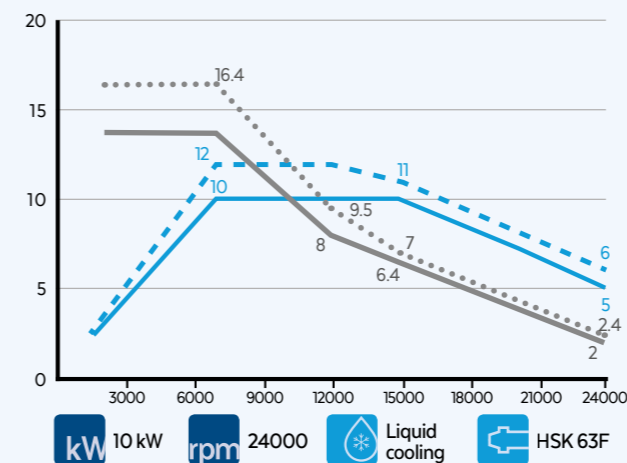

PX-2 12/12 24 63F NC

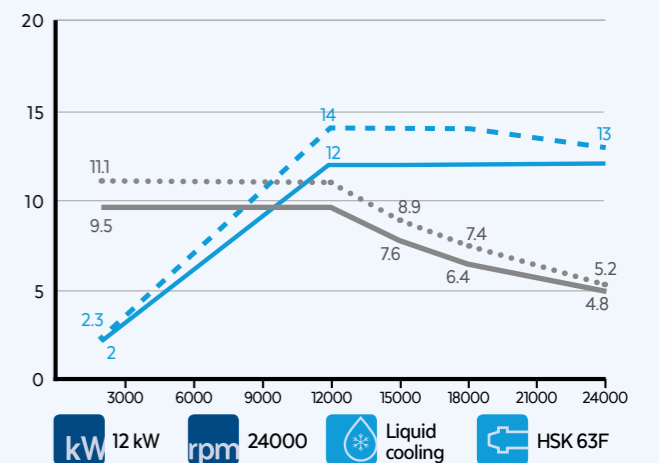

PX-2 15/12 24 63F NC

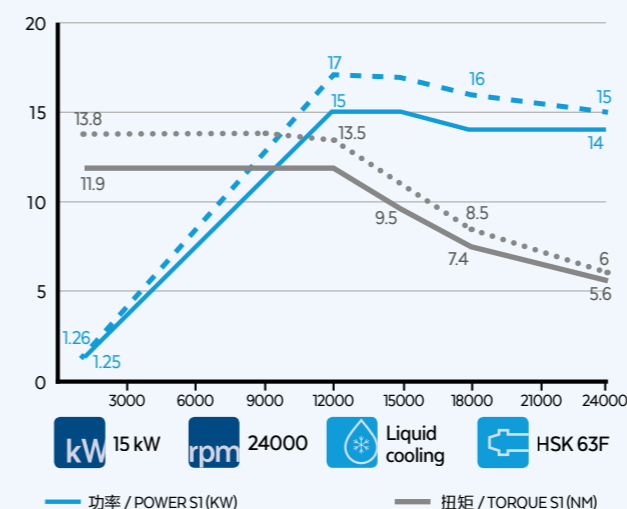

# 系列 TILT TILT K PLUS



AVAILABLE WITH



## LAYOUT

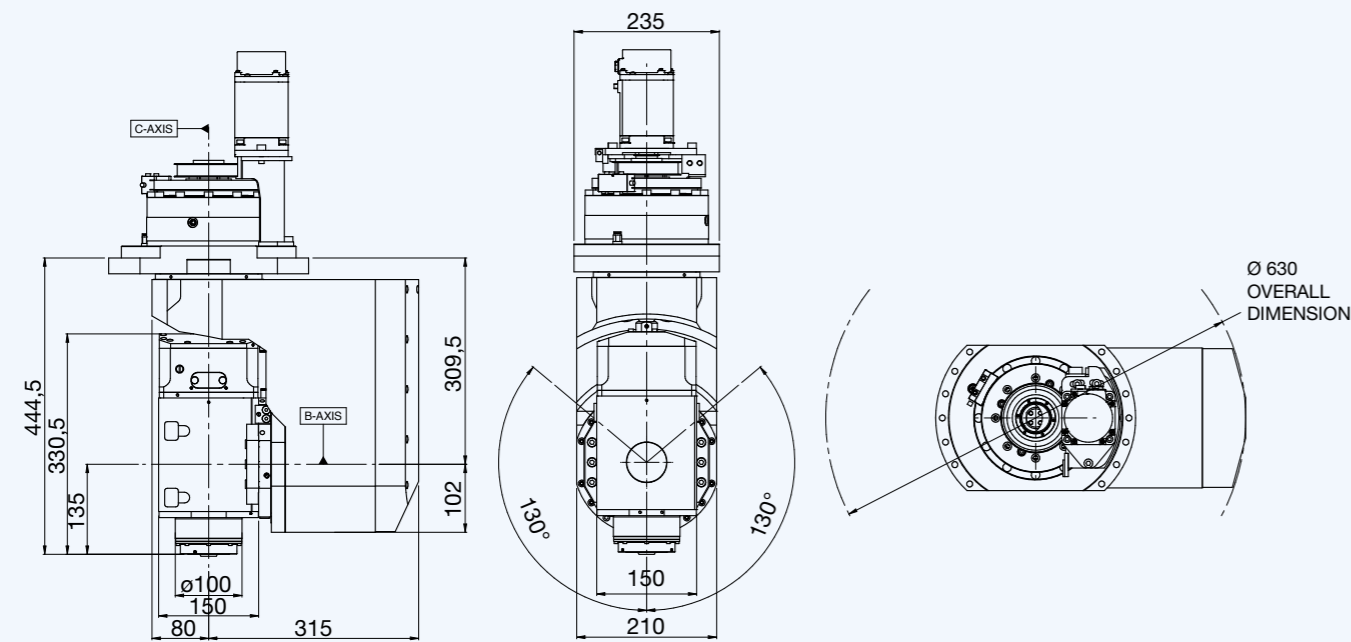

## 电主轴选择 / ELECTROSPINDLE OPTIONS

- HSK 63F
- HSK 63A
- Air tool
- Oil mist/MQL
- 轴承温度监控  
Temperature monitoring of bearings
- 震动传感器  
Vibration sensor
- Temperature sensor
- Speed monitoring
- Encoder 1Vpp or TTL

## 技术规格 / TECHNICAL SPECIFICATIONS

\* 可按需求提供其他品牌的马达  
\* Other engine brands are available on demand

	A轴 / A AXIS	C轴 / C AXIS
伺服电机 / Servomotor type	Yaskawa*	Yaskawa*
伺服电机功率 / Servomotor power	0,4 kW	0,65 kW
伺服电机编码器 / Servomotor encoder	绝对式 Absolute 20 Bit	绝对式 Absolute 20 Bit
齿轮箱 / Gearbox	Sumitomo	Sumitomo
连续扭矩 / Continuous torque	350 Nm	503 Nm
最大连续扭矩 / Max. continuous torque	1030 Nm	1030 Nm
轴最大转角 / Max. axis rotation	±130°	±320°
最大定位速度 / Max. positioning speed	6.700°/s	7.500°/s
精度 / Accuracy	±30 arsec	±30 arsec
重复性 / Repeatability	±10 arsec	±10 arsec
外部空气连接 / External air connection		n2
重量 / Weight		100 kg

## 可用电主轴 / AVAILABLE ELECTROSPINDLES

HX-2 13/7 24 63F NC

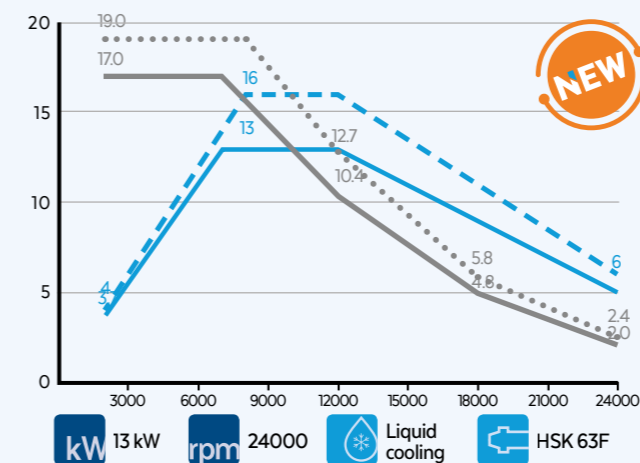

HX-2 12/12 24 63F NC

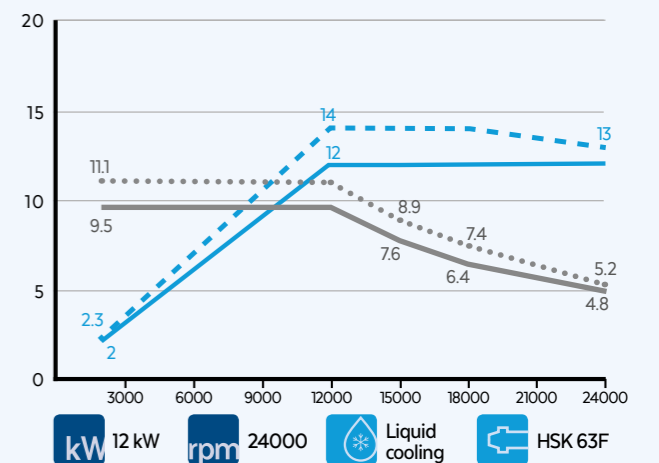

HX-2 15/12 24 63F NC

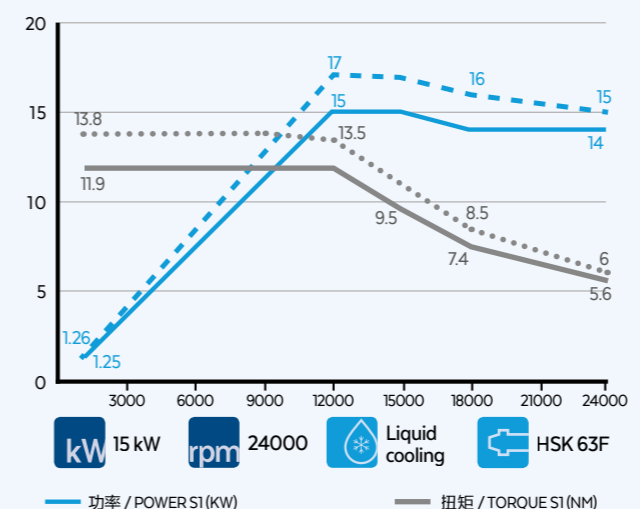



# 系列 TILT TILT H



- LIGHT ALLOYS
- ADVANCED MATERIALS
- PLASTIC

AVAILABLE WITH



## LAYOUT

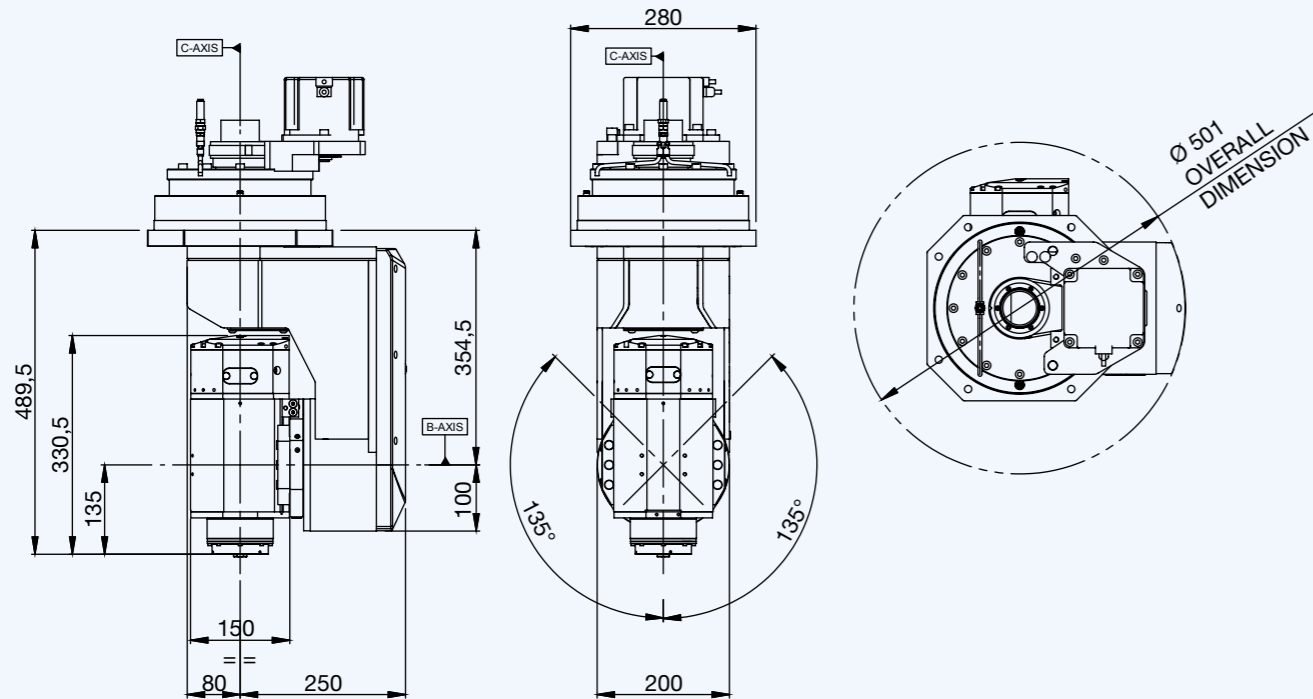

## 电主轴选择 / ELECTROSPINDLE OPTIONS

- 长鼻 / Long nose
- HSK 63E
- HSK 63A (Standard on 20 kw)
- 轴承温度监控 / Temperature monitoring of bearings
- 测速仪 / Speed monitoring
- 震动传感器 / Vibration sensor
- Encoder

## 技术规格 / TECHNICAL SPECIFICATIONS

\* 可按需求提供其他品牌的马达  
\* Other engine brands are available on demand

	ASSE A / A AXIS	C轴 / C AXIS
伺服电机 / Servomotor	Yaskawa*	Yaskawa*
伺服电机功率 / Servomotor power	0,40 kW	0,75 kW
伺服电机编码器 / Servomotor encoder	绝对式 Absolute 20 Bit	绝对式 Absolute 20 Bit
齿轮箱 / Gearbox	Harmonic Drive	Harmonic Drive
最大连续扭矩 / Max. continuous torque	380 Nm	460 Nm
峰值扭矩 / Peak torque	570 Nm	980 Nm
轴最大转角 / Max axis rotation	±135°	±320°
机械制动 / Mechanical blocking of axes	是 Yes	是 Yes
最大定位速度 / Max. positioning speed	6.100°/'	9.300°/'
最大工作速度 / Max operating speed	3.700°/'	5.600°/'
轴定位精度 / Axis positioning accuracy	1 arcmin	1 arcmin
重量 / Weight		120 kg

## 可用电主轴 / AVAILABLE ELECTROSPINDLES

PX-2 10/7 24 63F NC

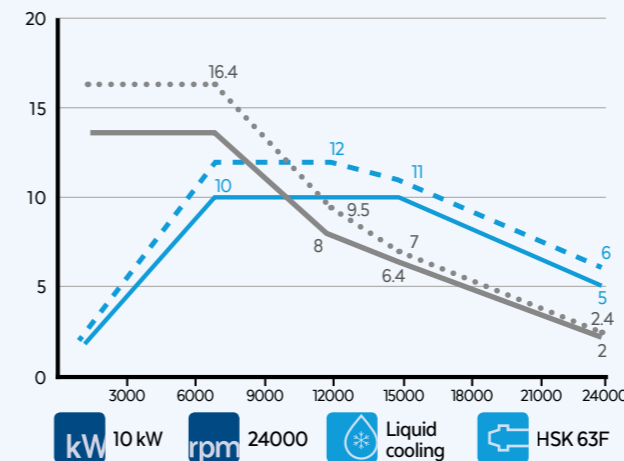

PX-2 15/12 24 63F NC

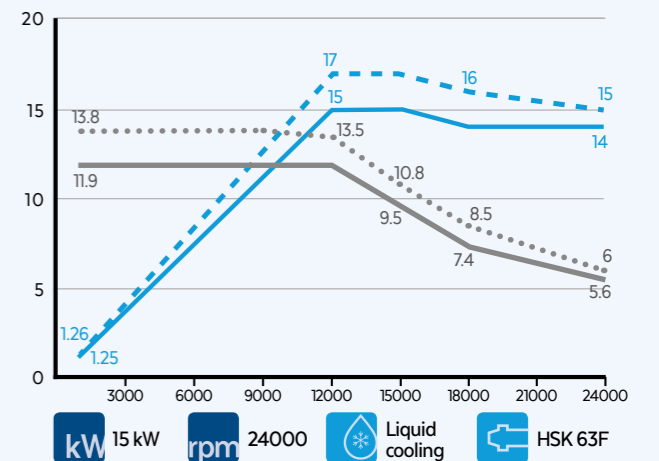

PX-2 18/12 24 63F NC

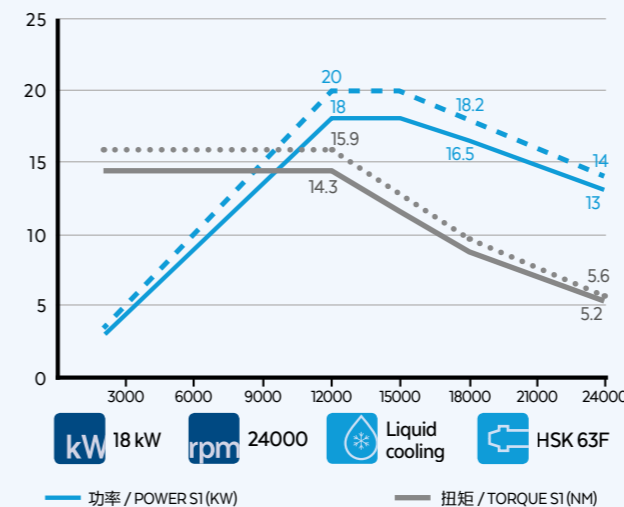

PX-2 20/10 24 63A NC ES SYNCHRONOUS

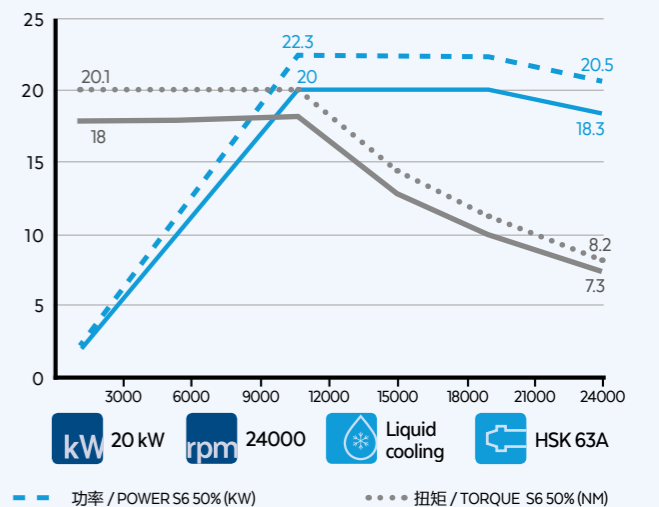

# 系列 TILT TILT H PLUS



- NEW**
- LIGHT ALLOYS
- ADVANCED MATERIALS
- PLASTIC

AVAILABLE WITH



## LAYOUT

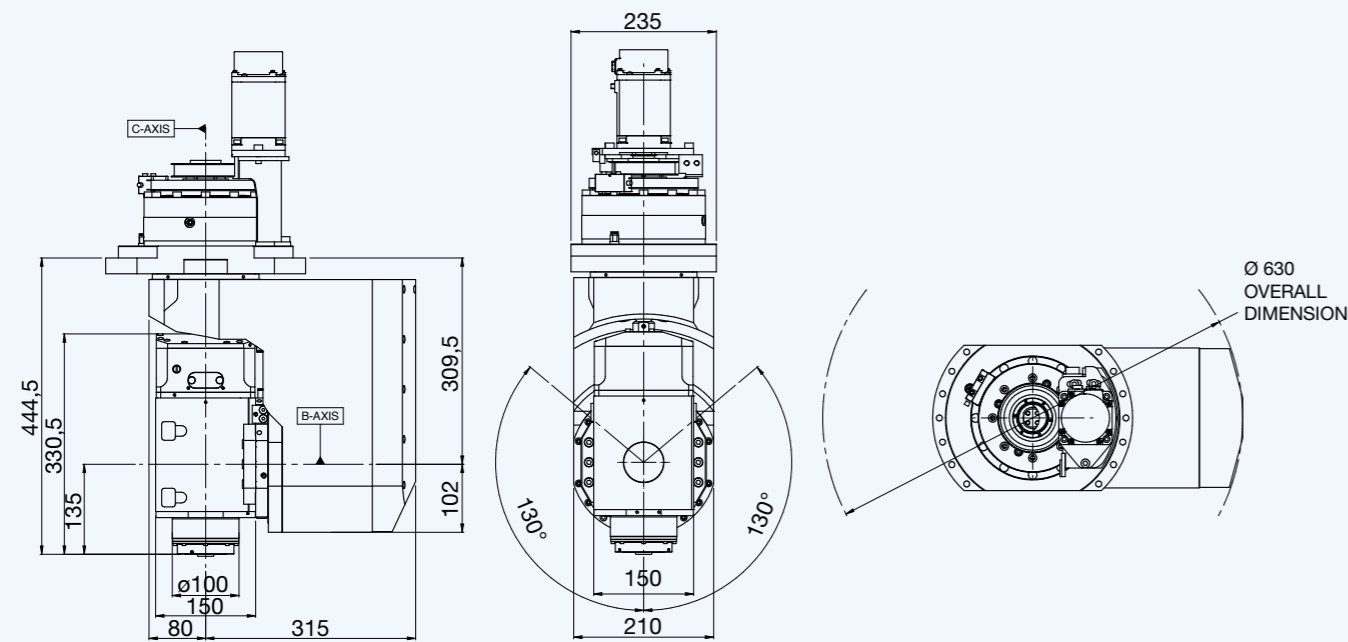

## 电主轴选择 / ELECTROSPINDLE OPTIONS

- HSK 63F
- HSK 63A
- Air tool
- Oil mist/MQL
- 轴承温度监控  
Temperature monitoring of bearings
- 震动传感器  
Vibration sensor
- Temperature sensor
- Speed monitoring
- Encoder 1Vpp o TTL

## 技术规格 / TECHNICAL SPECIFICATIONS

\* 可按需求提供其他品牌的马达  
\*Other engine brands are available on demand

	A轴 / A AXIS	C轴 / C AXIS
伺服电机 / Servomotor type	Yaskawa*	Yaskawa*
伺服电机功率 / Servomotor power	0,4 kW	0,65 kW
伺服电机编码器 / Servomotor encoder	绝对式 Absolute 20 Bit	绝对式 Absolute 20 Bit
齿轮箱 / Gearbox	Sumitomo	Sumitomo
连续扭矩 / Continuous torque	350 Nm	503 Nm
最大连续扭矩 / Max. continuous torque	1030 Nm	1030 Nm
轴最大转角 / Max. axis rotation	±130°	±320°
最大定位速度 / Max. positioning speed	6.700°/'	7.500°/'
机械制动 / Holding brake	是 Yes	是 Yes
轴编码器 / Axis encoder	是 Yes	是 Yes
精度 / Accuracy	±30 arsec (±5 arsec)*	±30 arsec (±5 arsec)*
重复性 / Repeatability	±10 arsec (±5 arsec)*	±10 arsec (±5 arsec)*
外部空气连接 / External air connection		n2
重量 / Weight		100 kg

\* 带轴编码器 / With encoder axis

## 可用电主轴 / AVAILABLE ELECTROSPINDLES

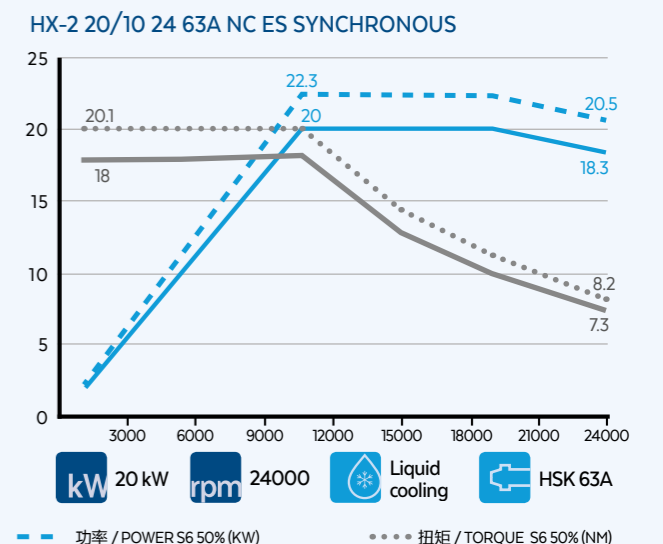
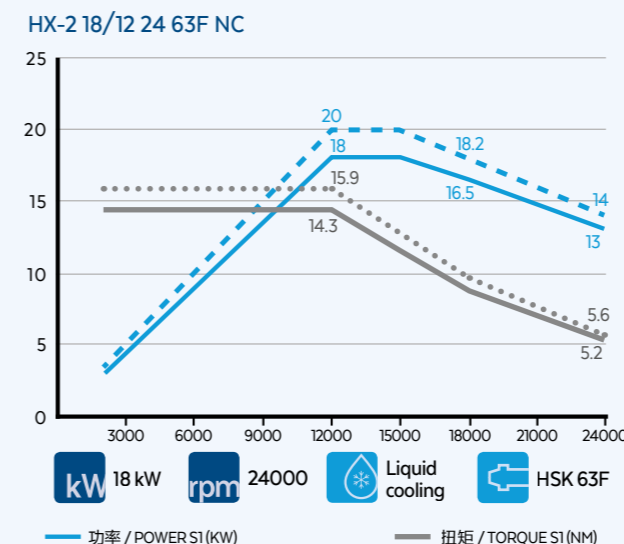
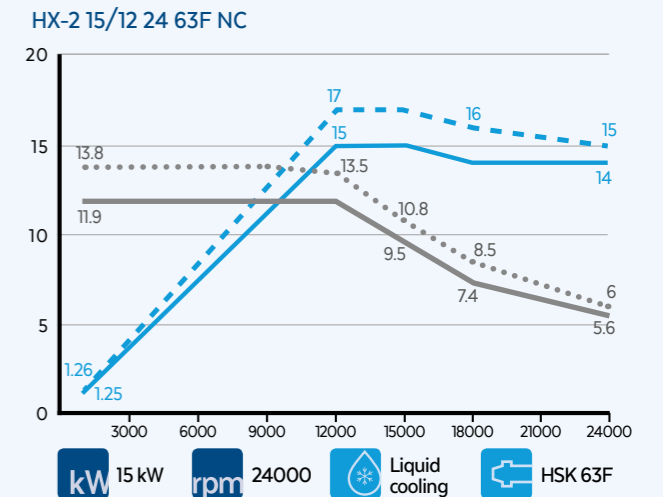
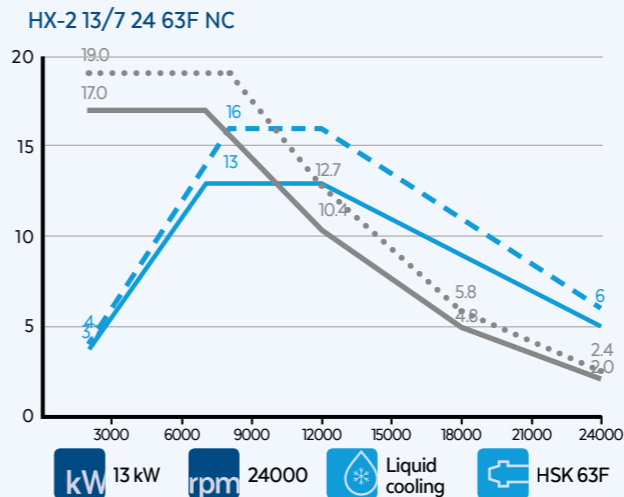

# 系列 TILT TILT V



- LIGHT ALLOYS
- ADVANCED MATERIALS
- PLASTIC
- WOOD

AVAILABLE WITH



## LAYOUT

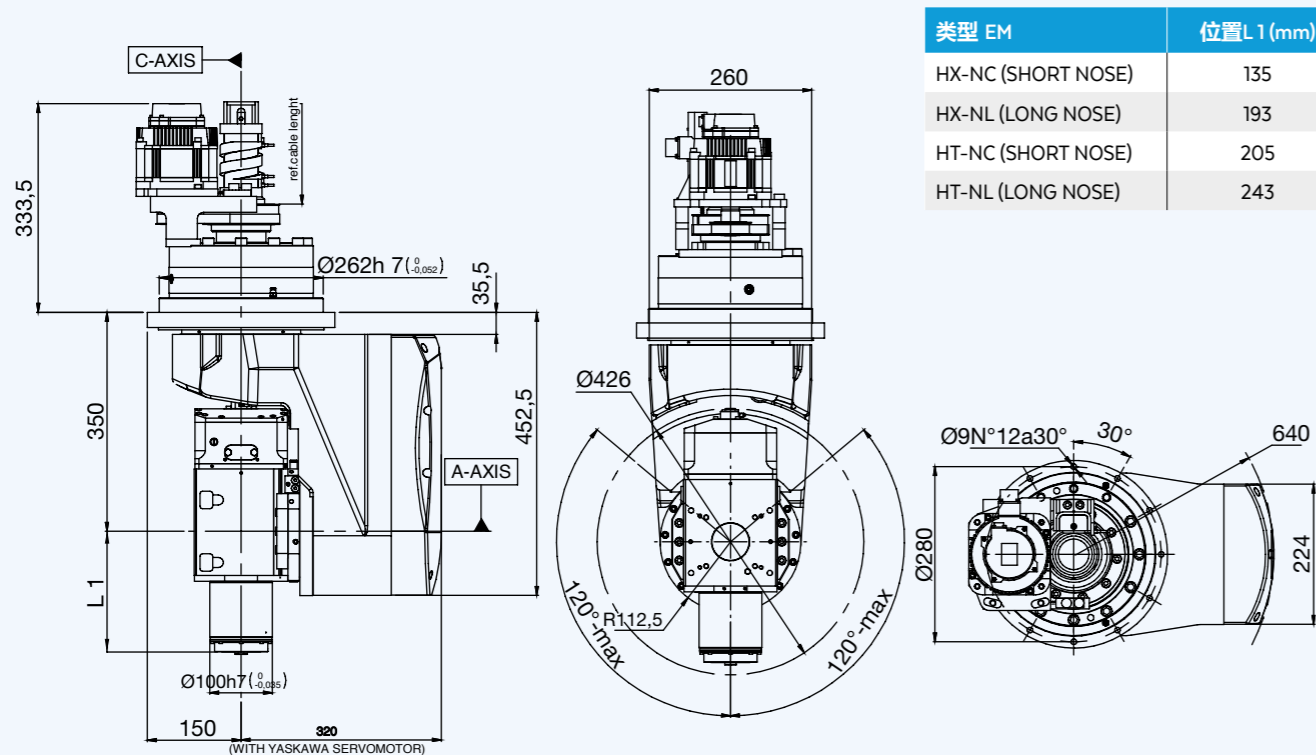

## 电主轴选择 / ELECTROSPINDLE OPTIONS

- 短鼻 / Short nose
- HSK 63E
- HSK 63A
- Oil mist/MQL
- 轴承温度监控 / Temperature monitoring of bearings
- 测速仪 / Speed monitoring
- 震动传感器 / Vibration sensor
- Air tool

\* HT主轴比表中所示的值大50mm  
\* When the unit is with HT spindle the quote increases by 50 mm from the one represented in the plan

## 技术规格 / TECHNICAL SPECIFICATIONS

\* 可按需求提供其他品牌的马达  
\* Other engine brands are available on demand

	ASSE A / A AXIS	C轴 / C AXIS
伺服电机 / Servomotor	Yaskawa*	Yaskawa*
伺服电机功率 / Servomotor power	0,75 kW	0,85 kW
伺服电机编码器 / Servomotor encoder	绝对式 Absolute 20 Bit	绝对式 Absolute 20 Bit
齿轮箱 / Gearbox	Sumitomo	Sumitomo
最大连续扭矩 / Max. continuous torque	425 Nm	635 Nm
峰值扭矩 / Peak torque	1030 Nm	1962 Nm
轴最大转角 / Max axis rotation	±120°	±320°
最大定位速度 / Max. positioning speed	10.000°/'	12.500°/'
机械制动 / Mechanical blocking of axes	是 Yes	是 Yes
轴编码器 / Axis encoder optional	是 Yes (OPT)	是 Yes (OPT)
精度 / Accuracy	±30 arcsec (±5 arcsec)*	±30 arcsec (±5 arcsec)*
重复性 / Repeatability	±10 arcsec (±5 arcsec)*	±10 arcsec (±5 arcsec)*
外部空气连接 / External air connections		n2
重量 / Weight		150 kg

\* 带轴编码器 / With encoder axis

## 可用电主轴 / AVAILABLE ELECTROSPINDLES

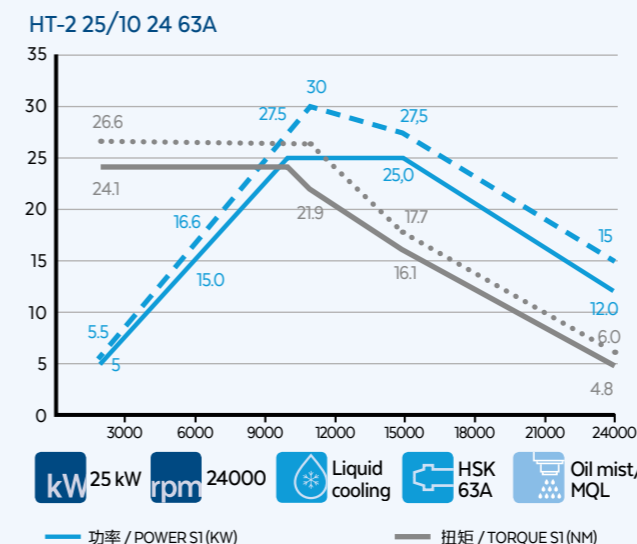
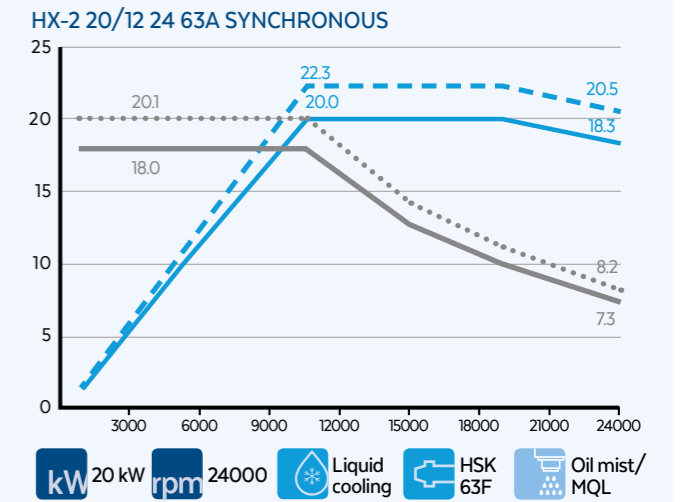
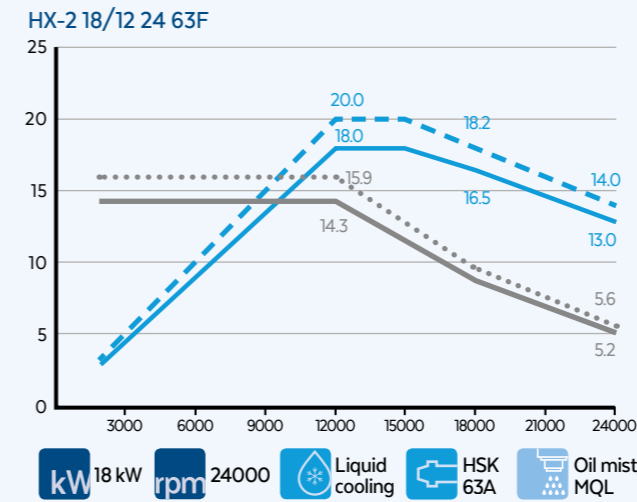



# 系列 TILT TILT V QT

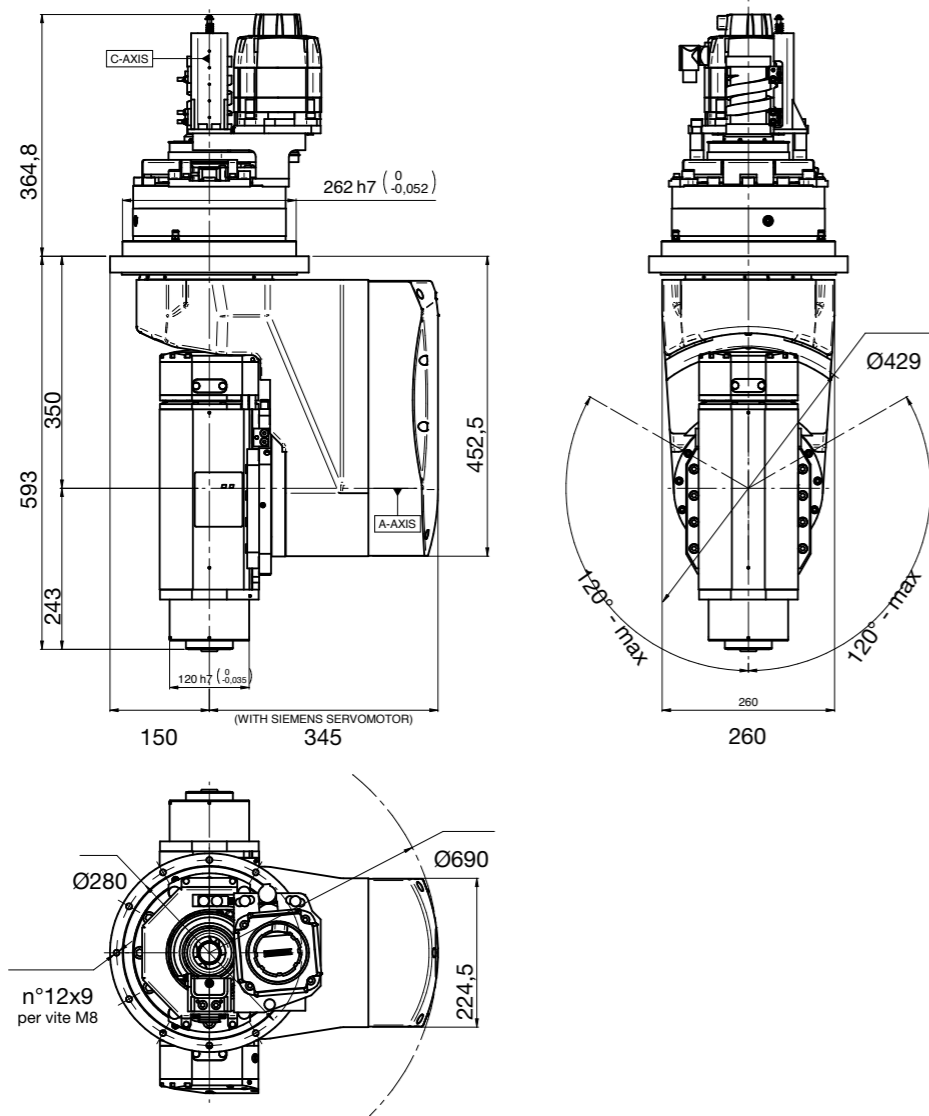

QT-2 16/6 16 63E NC

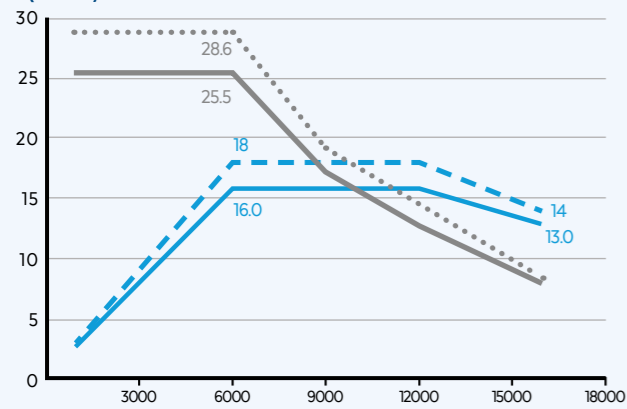

kW 16 kW  
 rpm 16000  
 Liquid cooling  
 HSK 63E

— 功率 / POWER S1 (KW)  
 — 扭矩 / TORQUE S1 (NM)

QT-2 25/7 16 63E NC ES

SYNCHRONOUS

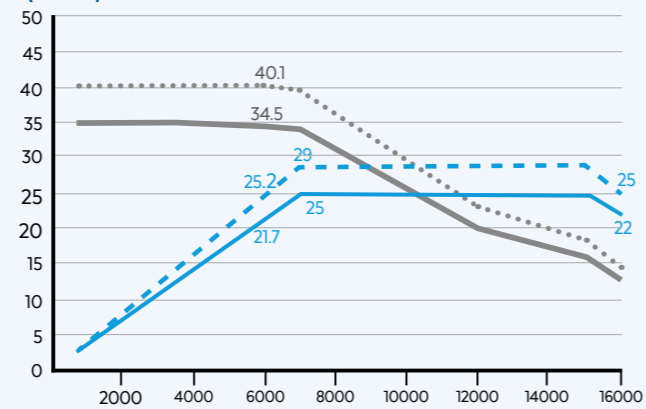

kW 25 kW  
 rpm 24000  
 Liquid cooling  
 HSK 63E

Encoder 1Vpp o TTL

— 功率 / POWER S6 50% (KW)  
 — 扭矩 / TORQUE S6 50% (NM)



# 系列 TILT TILT W



- LIGHT ALLOYS
- ADVANCED MATERIALS
- PLASTIC
- WOOD

AVAILABLE WITH



## LAYOUT

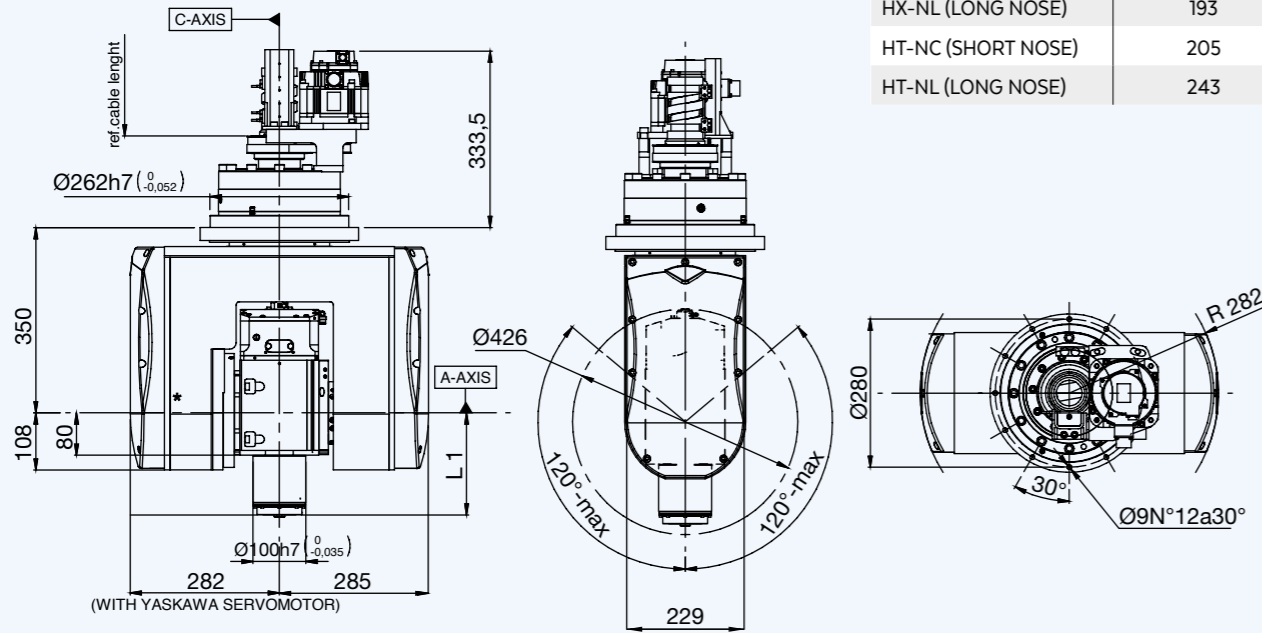

类型 EM	位置 L1 (mm)
HX-NC (SHORT NOSE)	135
HX-NL (LONG NOSE)	193
HT-NC (SHORT NOSE)	205
HT-NL (LONG NOSE)	243

## 电主轴选择 / ELECTROSPINDLE OPTIONS

- 短鼻 Short nose
- 测速仪 Speed monitoring
- HSK 63F
- 震动传感器 Vibration sensor
- HSK 63A
- Air tool
- Oil mist/MQL
- 轴承温度监控 Temperature monitoring of bearings

\* HT主轴表中所示的值大50mm  
\* When the unit is with HT spindle the quote increases by 50 mm from the one represented in the plan

## 技术规格 / TECHNICAL SPECIFICATIONS

\* 可按需求提供其他品牌的马达  
\* Other engine brands are available on demand

	ASSE A / A AXIS	C轴 / C AXIS
伺服电机 / Servomotor	Yaskawa*	Yaskawa*
伺服电机功率 / Servomotor power	0,75 kW	0,85 kW
伺服电机编码器 / Servomotor encoder	绝对式 Absolute 20 Bit	绝对式 Absolute 20 Bit
齿轮箱 / Gearbox	Sumitomo	Sumitomo
最大连续扭矩 / Max. continuous torque	425 Nm	635 Nm
峰值扭矩 / Peak torque	1030 Nm	1962 Nm
轴最大转角 / Max axis rotation	±120°	±320°
最大定位速度 / Max. positioning speed	10.000°/'	12.500°/'
机械制动 / Mechanical blocking of axes	是 Yes	是 Yes
轴编码器 / Axis encoder optional	是 Yes (OPT)	是 Yes (OPT)
精度 / Accuracy	±30 arcsec (±5 arcsec)*	±30 arcsec (±5 arcsec)*
重复性 / Repeatability	±10 arcsec (±5 arcsec)*	±10 arcsec (±5 arcsec)*
外部空气连接 / External air connections		n2
重量 / Weight		210 kg

\* 带轴编码器 / With encoder axis

## 可用电主轴 / AVAILABLE ELECTROSPINDLES

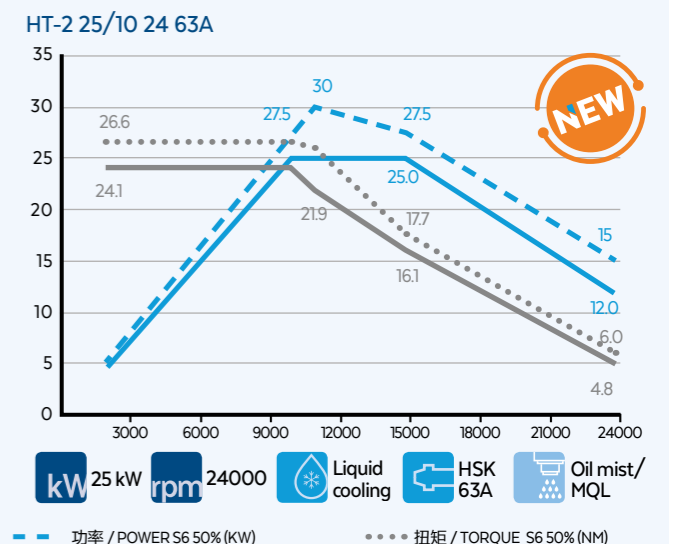
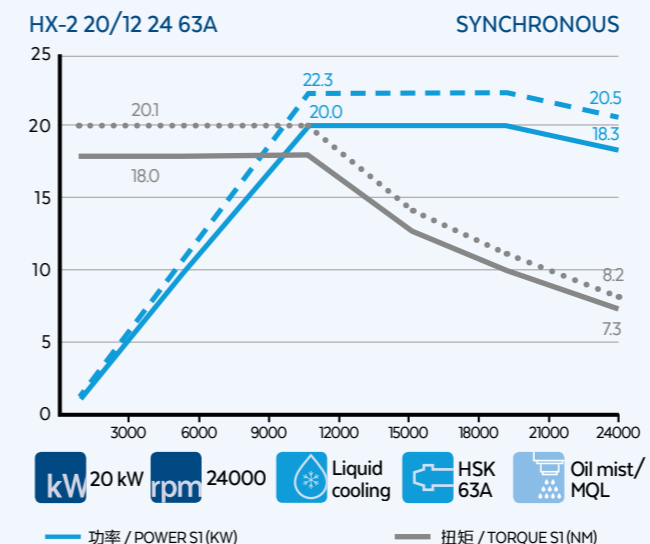
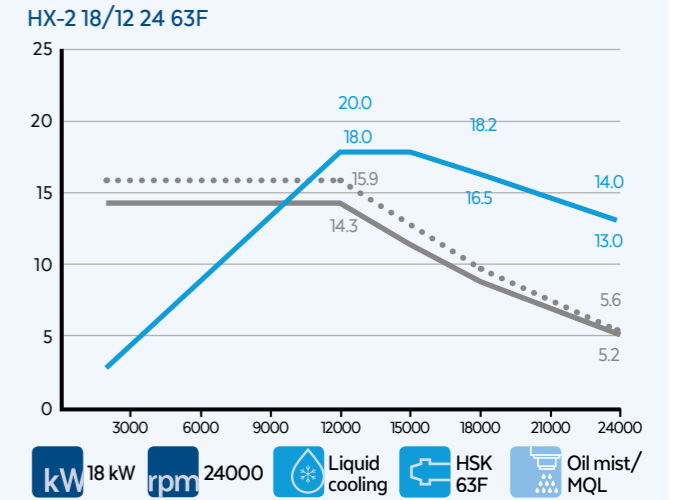
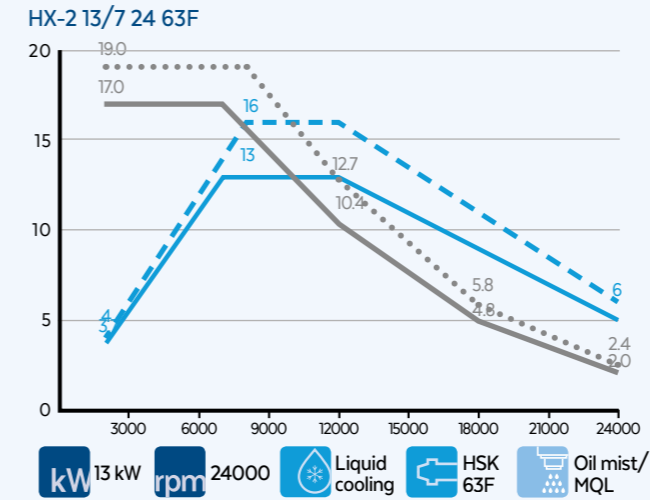

# 系列 TILT TILT TLP



- LIGHT ALLOYS
- ADVANCED MATERIALS
- PLASTIC
- WOOD

AVAILABLE WITH



## LAYOUT

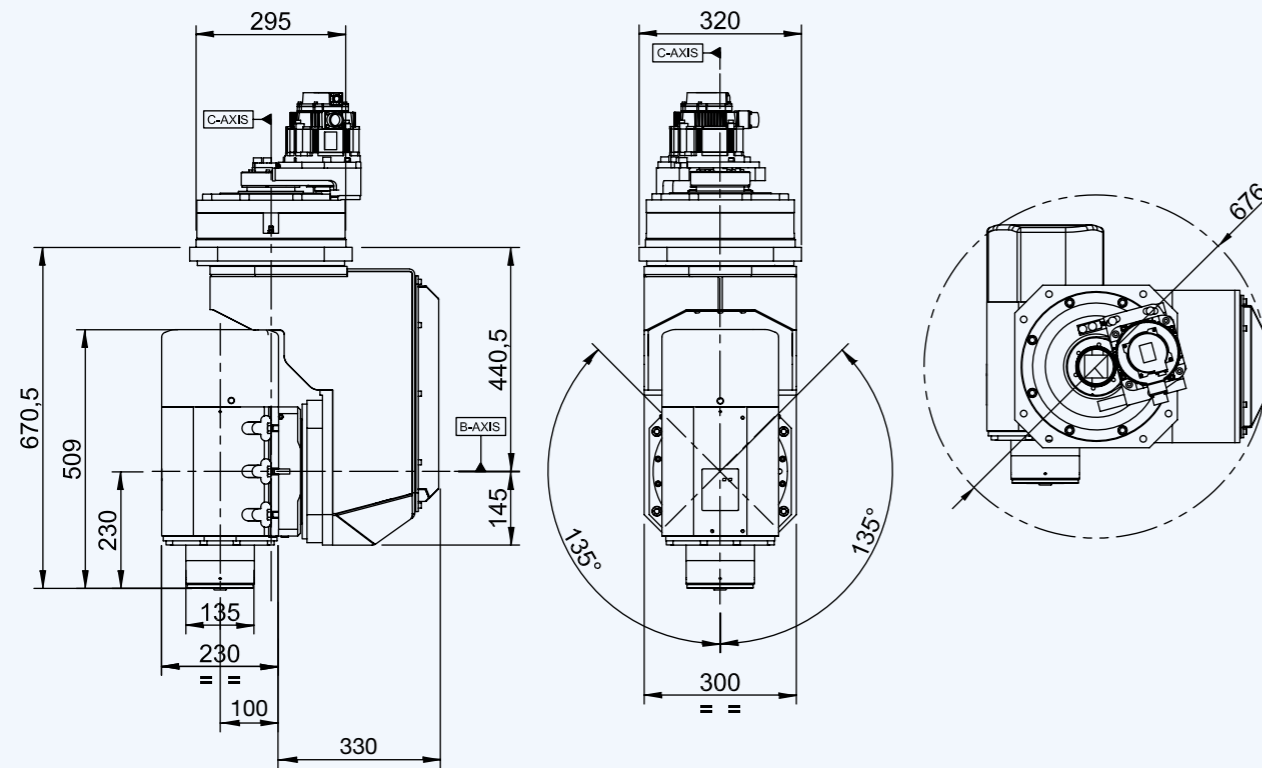

## 电主轴选择 / ELECTROSPINDLE OPTIONS

- Oil mist/MQL
- 轴承温度监控  
Temperature monitoring of bearings
- 测速仪  
Speed monitoring
- 震动传感器  
Vibration sensor
- Air tool
- Encoder (standard with hsk 63A)

## 技术规格 / TECHNICAL SPECIFICATIONS

\* 可按需求提供其他品牌的马达  
\*Other engine brands are available on demand

	ASSE A / A AXIS	C轴 / C AXIS
伺服电机 / Servomotor	Yaskawa*	Yaskawa*
伺服电机功率 / Servomotor power	0,75 kW	0,85 kW
伺服电机编码器 / Servomotor encoder	绝对式 Absolute 20 Bit	绝对式 Absolute 20 Bit
齿轮箱 / Gearbox	Sumitomo	Sumitomo
最大连续扭矩 / Max. continuous torque	800 Nm	636 Nm
峰值扭矩 / Peak torque	1962 Nm	3188 Nm
轴最大转角 / Max axis rotation	±135°	±320°
最大定位速度 / Max. positioning speed	10.000°/'	11.000°/'
机械制动 / Mechanical blocking of axes	是 Yes	是 Yes
轴编码器 / Axis encoder optional	是 Yes (OPT)	是 Yes (OPT)
精度 / Accuracy	±30 arcsec (±5 arcsec)*	±30 arcsec (±5 arcsec)*
重复性 / Repeatability	±10 arcsec (±5 arcsec)*	±10 arcsec (±5 arcsec)*
最大工作速度 / Max operating speed	3.700°/'	5.600°/'
轴定位精度 / Axis positioning accuracy	1 arcmin	1 arcmin
重量 / Weight		250 kg

\* 带轴编码器 / With encoder axis

## 可用电主轴 / AVAILABLE ELECTROSPINDLES

### QM-2 30/6 13 80F NC

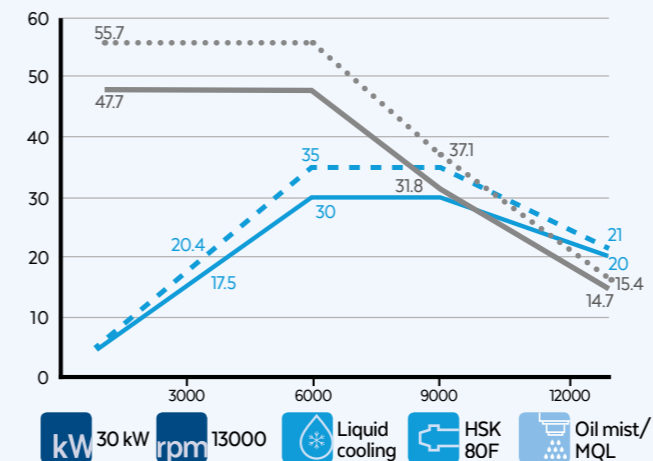

### QM-2 30/6 13 63A NC ES

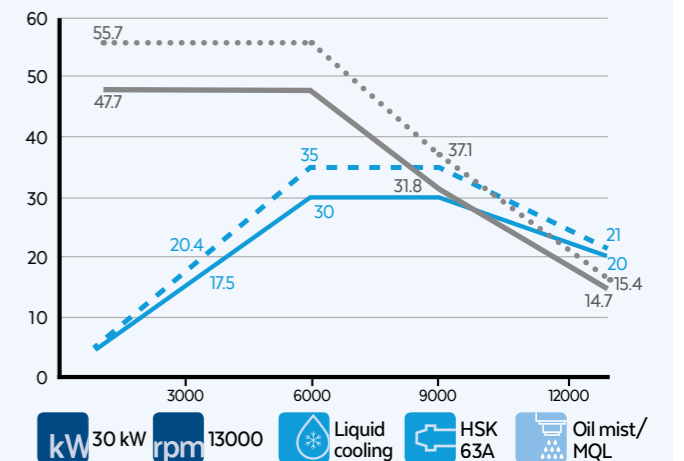

### QM-2 30/6 13 85S NC

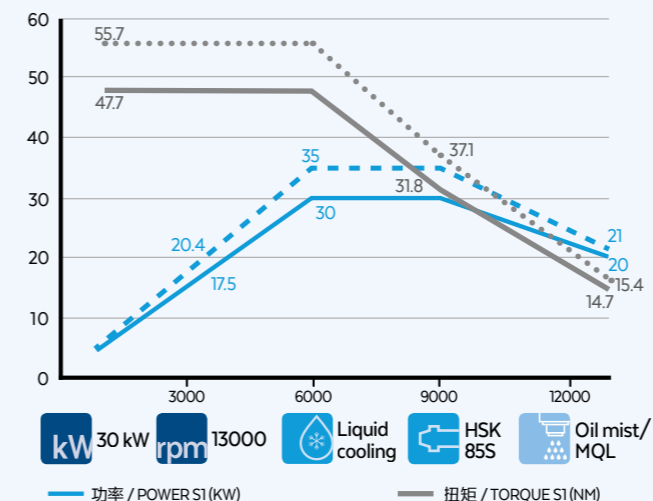







ss 258 Marecchia, 34 47826 Villa Verucchio, Rimini - Italia

tel. +39.0541.674940 - fax +39.0541.674962

[www.hiteco.net](http://www.hiteco.net)