

SERIE TILT TILT K



SPECIFICHE TECNICHE / TECHNICAL SPECIFICATIONS

*Sono disponibili altre marche di motorizzazioni a richiesta
*Other engine brands are available on demand

	ASSE A / A AXIS	ASSE C / C AXIS
Servomotore / Servomotor	Yaskawa*	Yaskawa*
Potenza servomotore / Servomotor power	0,40 kW	0,40 kW
Encoder servomotore / Servomotor encoder	Assoluto Absolute 20 Bit	Assoluto Absolute 20 Bit
Riduttore / Gearbox	Harmonic Drive	Harmonic Drive
Coppia max continua / Max. continuous torque	380 Nm	380 Nm
Coppia di picco / Peak torque	570 Nm	570 Nm
Max rotazione asse / Max axis rotation	±135°	±320°
Freni meccanici / Mechanical blocking of axes	No	No
Velocità posizionamento max / Max. positioning speed	6.100°/'	6.100°/'
Velocità di lavoro max / Max operating speed	3.700°/'	3.700°/'
Precisione di posizionamento assi / Axis positioning accuracy	1 arcmin	1 arcmin
Peso / Weight		100 kg

LAYOUT

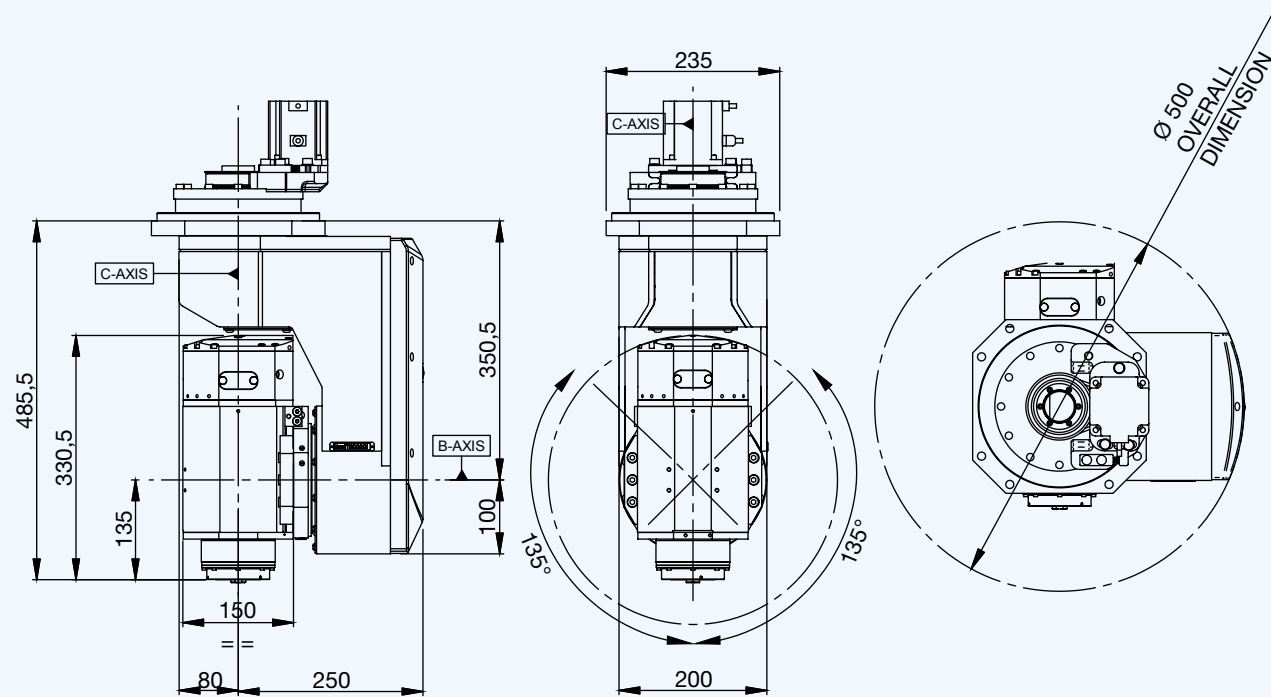

OPTIONALS DELL'ELETTROMANDRINO / ELECTROSPINDLE OPTIONS

- Naso lungo
Long nose
- HSK 63E
- HSK 63A
- Monitoraggio temperatura cuscinetti
Temperature monitoring of bearings
- Misuratore di velocità
Speed monitoring
- Sensori di vibrazione
Vibration sensor
- Encoder

ELETTROMANDRINI DISPONIBILI / AVAILABLE ELECTROSPINDLES

PX-2 10/7 24 63F NC

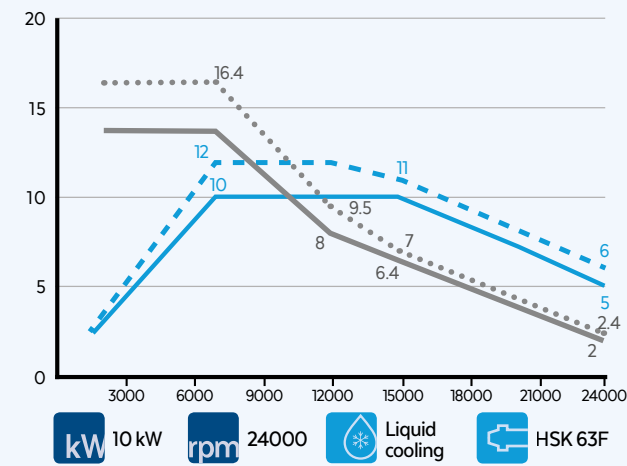

PX-2 12/12 24 63F NC

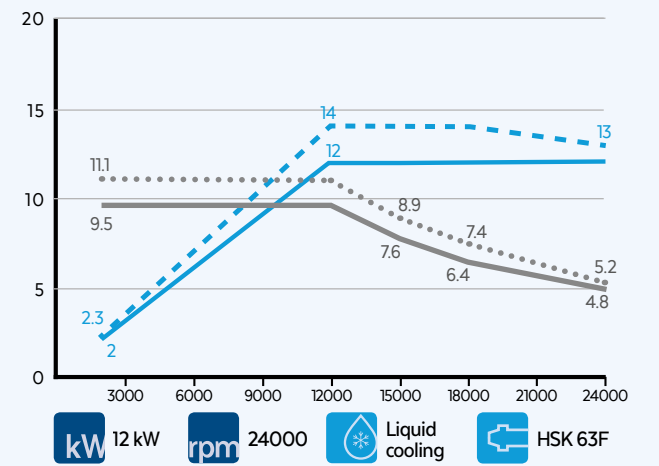

PX-2 15/12 24 63F NC

