

TOOL INTERFACE:
HSK25E

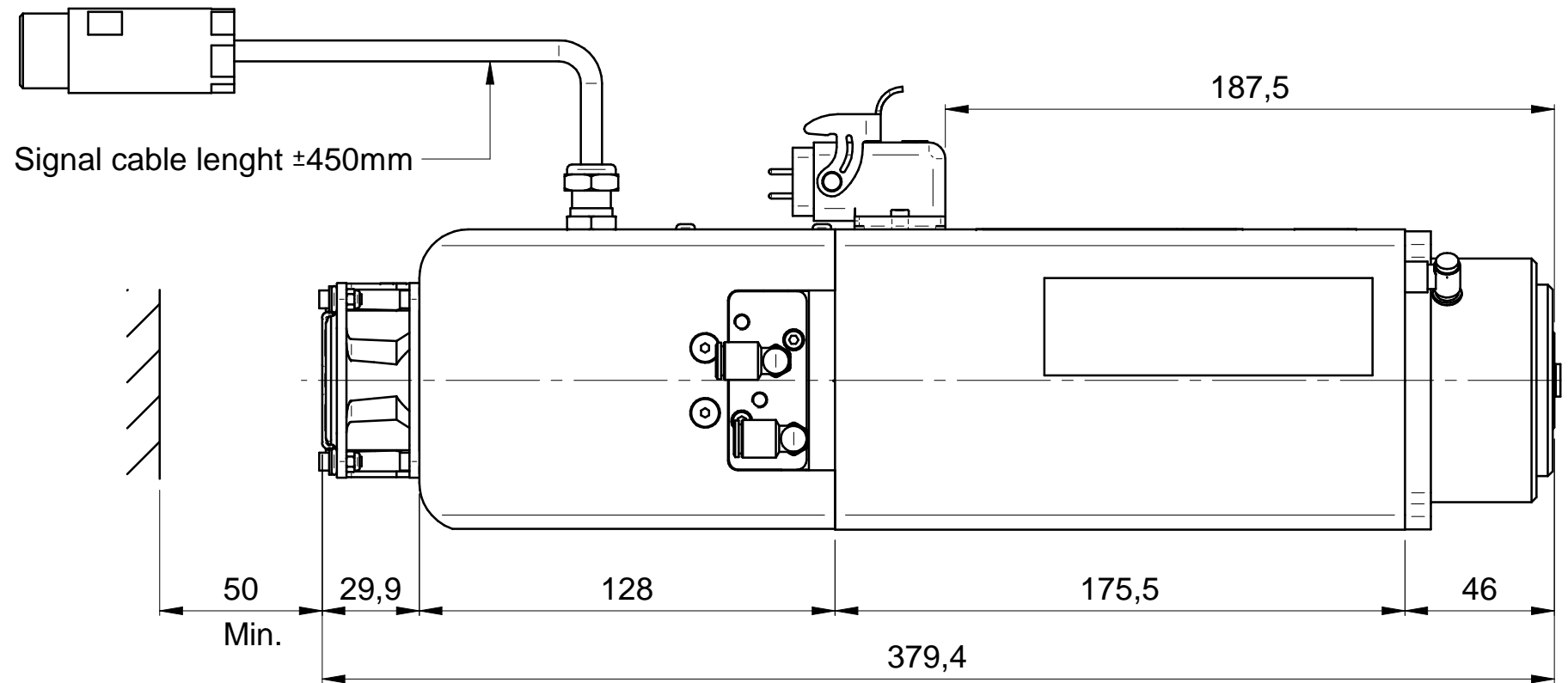
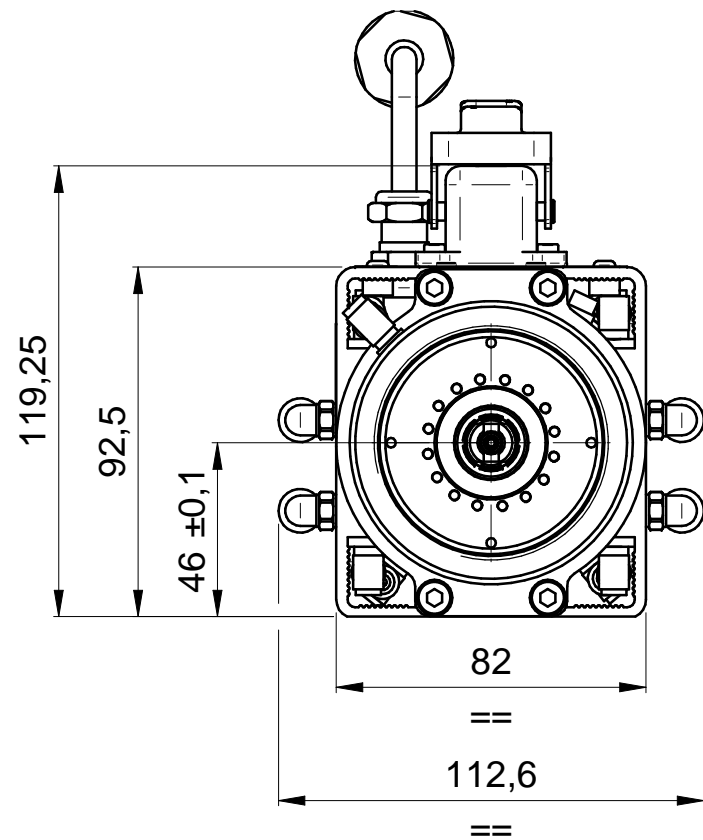
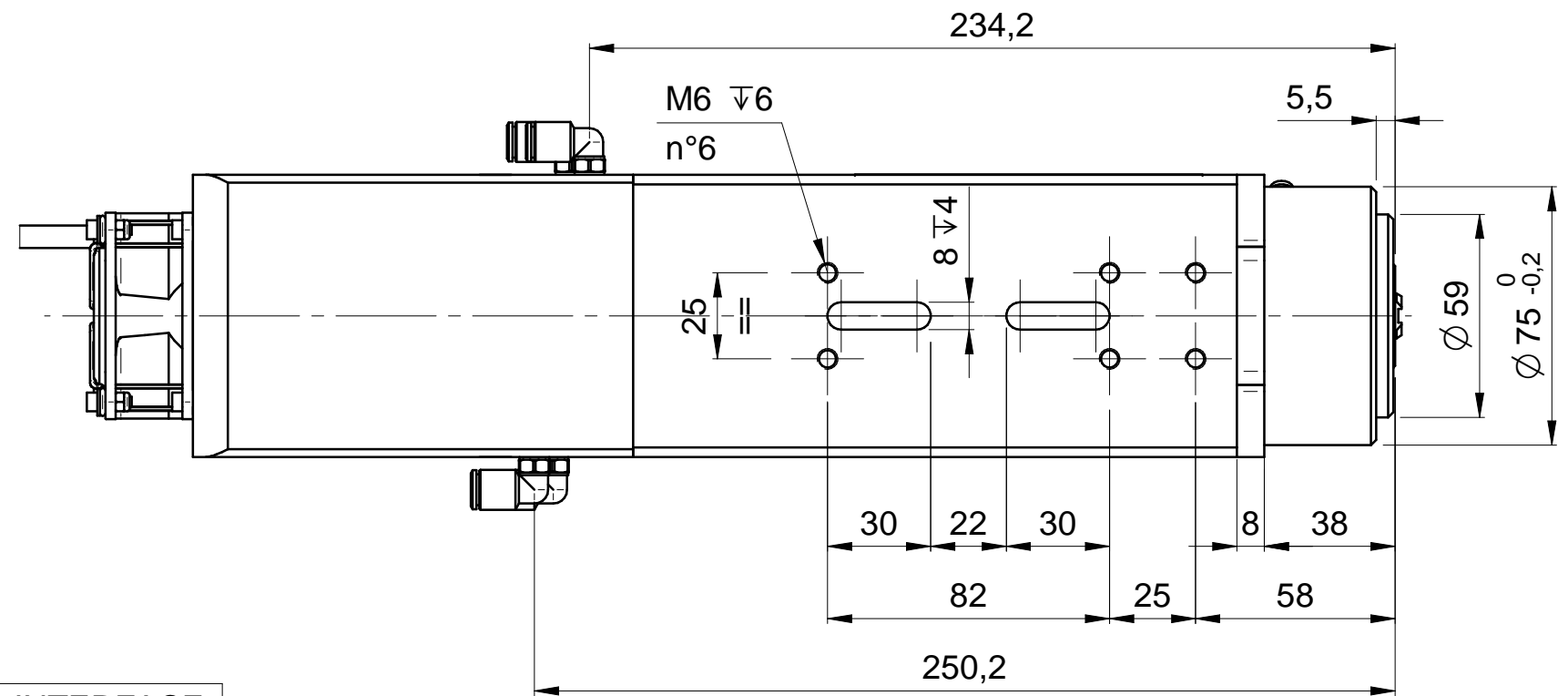

Signal cable length ±450mm

MASSA / WEIGHT: 9 kg

SCHEMA DI REGOLAZIONE SENSORI : 90L0898321H

SCHEMA DI COLLEGAMENTO ELETT. PNEUM. : 90L0867361E

Firma / Signature		Data / Date			
Controllato / Checked by					
Disegnato / Designed by					
Rev	Data / Date	Firma / Signature	N° Modifica / Change ID		
Descrizione ultima modifica / Last change description					
Denominazione / Item Name					
ELETM HS -1F 1.7/24 30 25E NC CC					
Scala / Scale		Codice / Item ID		Rev	Status
1:2		29L0935452C		01	
				Tav. N. di N.	3/3
<small>CI RISERVIAMO A TERMINI DI LEGGE LA PROPRIETA' DI QUESTO DISEGNO CON DIVIETO DI RENDERLO COMUNQUE NOTO A TERZI SENZA LA NOSTRA PREVENTIVA APPROVAZIONE. / THIS DRAWING IS SCM-PROPERTY. COPYRIGHTED MATERIAL DISCLOSURE TO THIRD PARTIES WITHOUT OUR AUTHORISATION IS EXPLICITLY FORBIDDEN.</small>					