

Elettromandrino / electrospindle
ML-2 9.5/12 24 ER40 DX-SX
Codice / Code:
29L0498694G

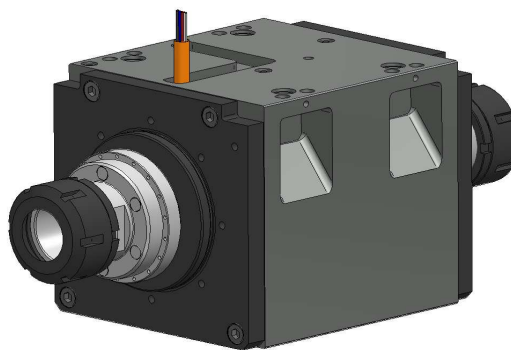

Prestazioni - Performances

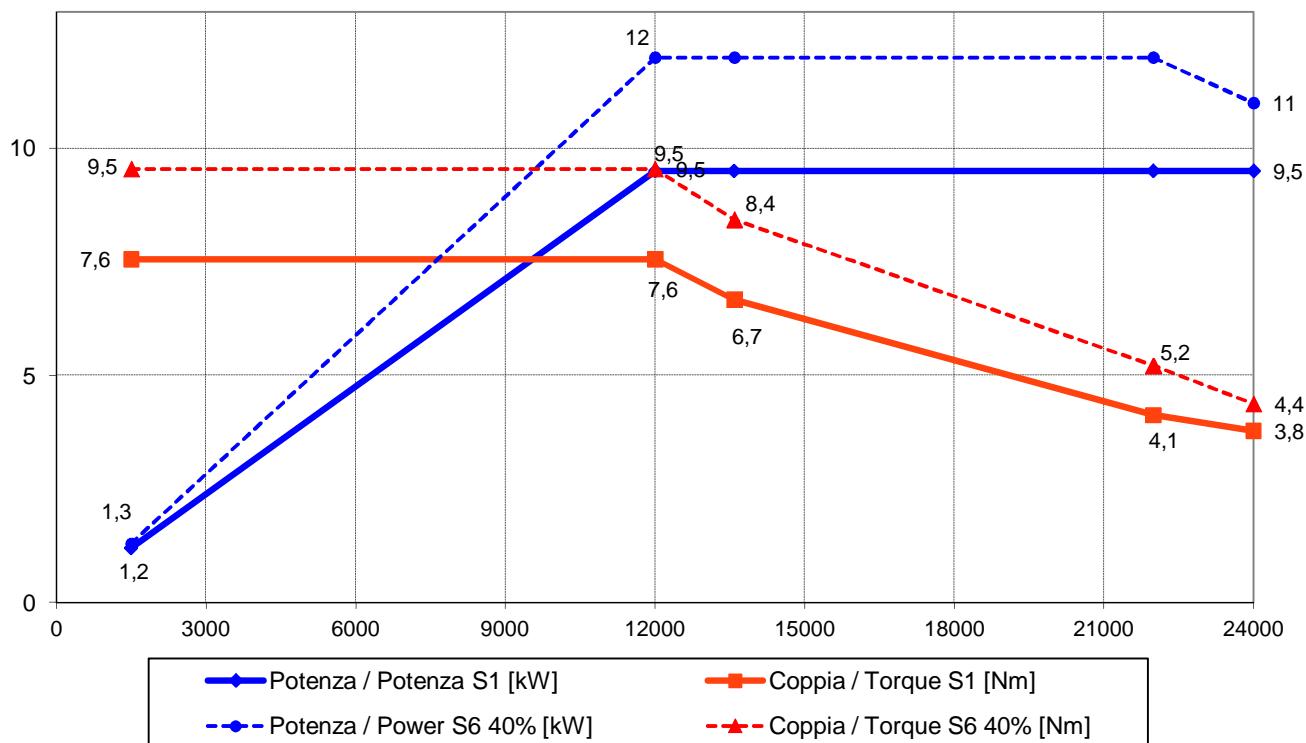

Specifiche tecniche / Technical specifications	
Potenza max. (serv. S1) / Max. Power.(S1 duty)	9.5 kW @ 12000 rpm
Coppia max. (serv. S1) / Max. Torque (S1 duty)	7,6 Nm
Corrente (serv. S1) / Current (serv. S1)	22 A
Potenza max. (serv. S6 40%) / Max. Power.(S6 40% duty)	12 kW @ 12000 rpm
Coppia max. (serv. S6 40%) / Max. Torque (S6 40% duty)	9,5 Nm
Corrente (serv. S6 60%) / Current (S6 60% duty)	27 A
Tensione / Voltage	380 V
Numero poli / Poles	4
Velocità rotazione max / Max Speed	24 000 rpm
Rotazione / Rotation	CW - CCW
Azionamento / Supply	con inverter / by inverter
Attacco utensile / Tool interface	ER40 DX-SX
Cuscinetti / Ball bearings	Obliqui ad alta velocità alta precisione / High speed high precision angular contact ball bearings Ant./Front: coppia / pair Post./Rear: coppia / pair
Raffreddamento / Cooling	a liquido mediante scambiatore di calore/ liquid by heat exchanger
Peso / Weight	26 kg