

TARGHETTA IDENTIFICATIVA
03L0433679B

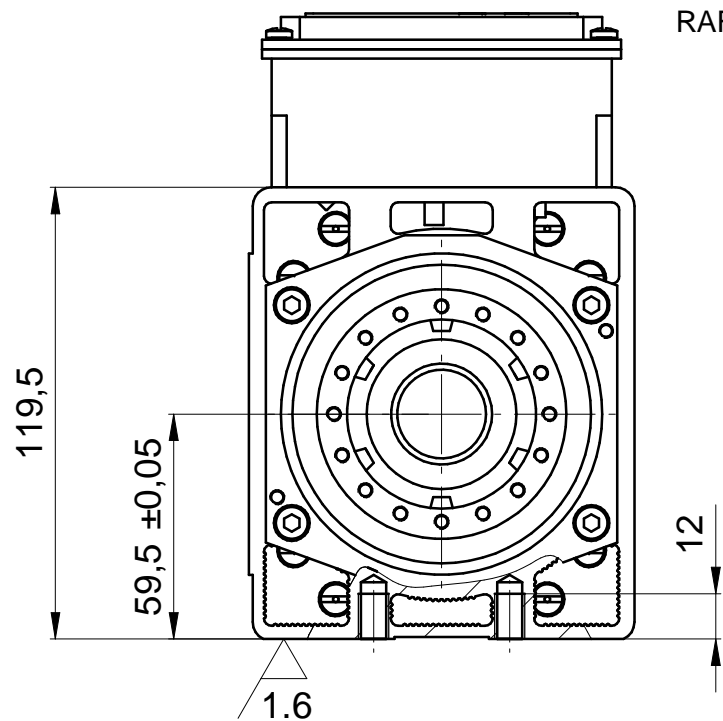

RAFFREDDAMENTO: E8 ARIA SECCA 6-6,5 bar
AIR COOLING: E8 DRY AIR 6-6,5 bar

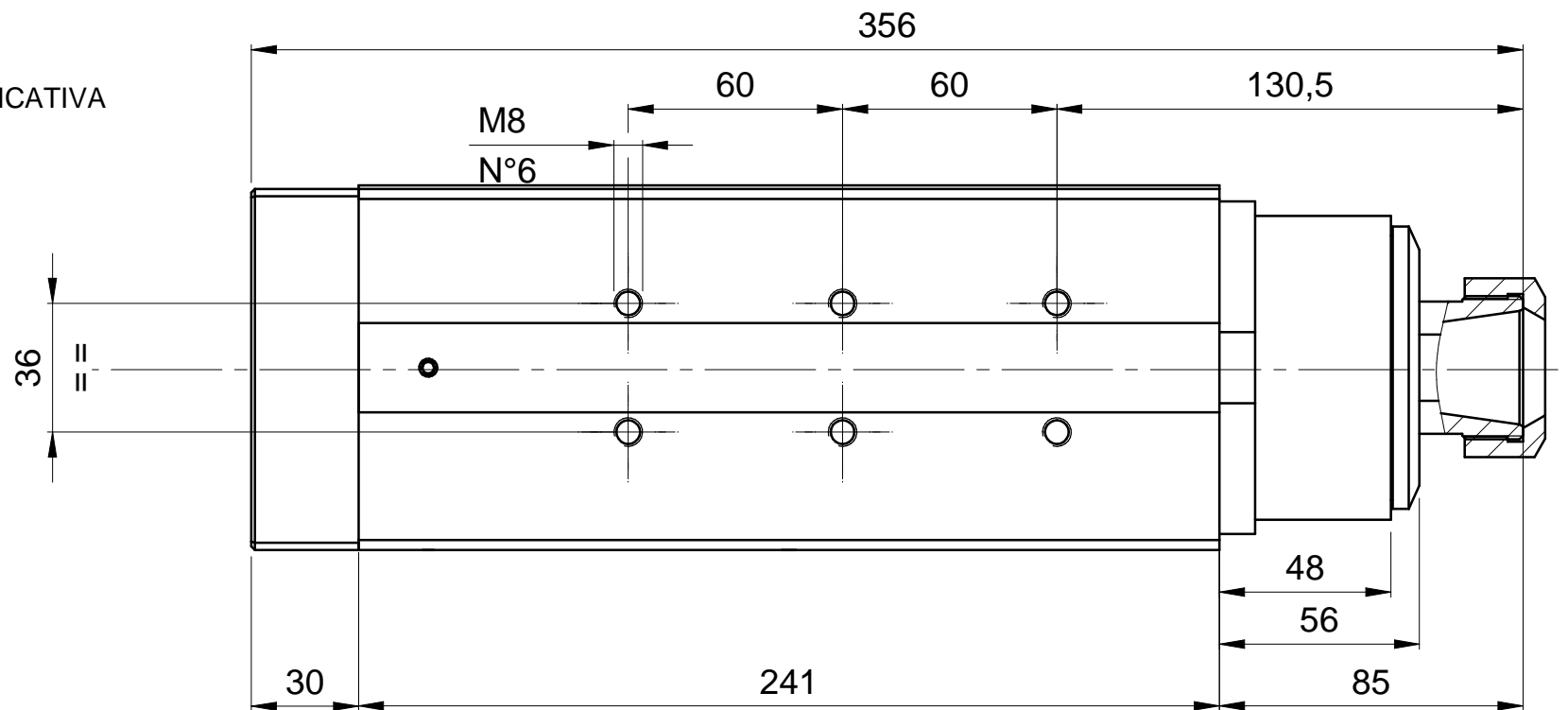
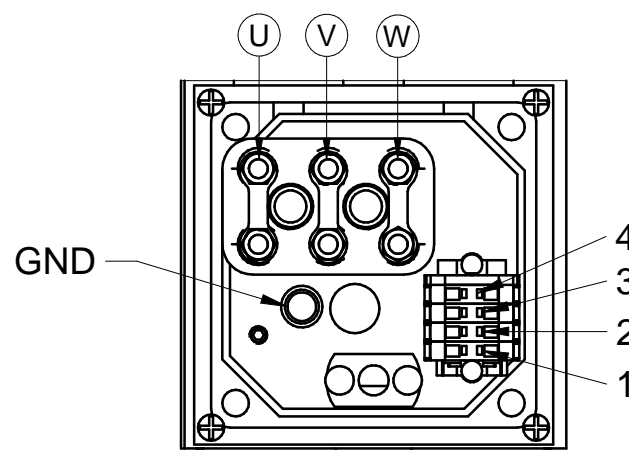
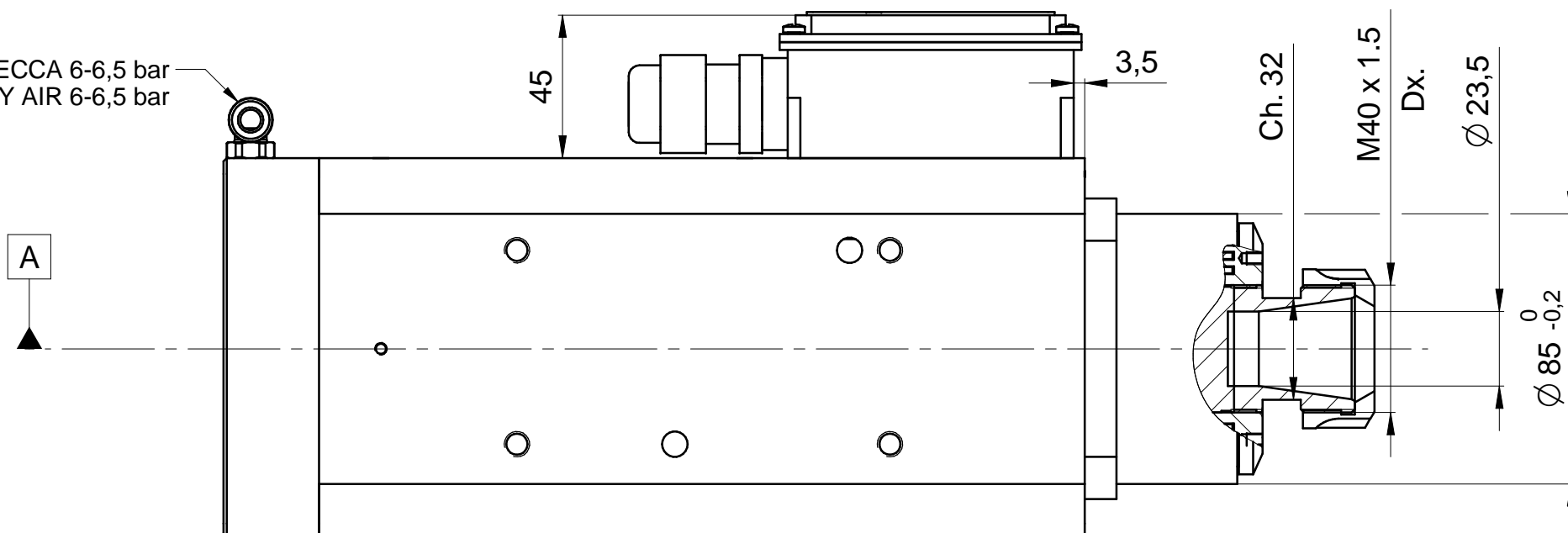

CONNESSIONI ELETTRICHE DI POTENZA/ POWER ELECTRIC CONNECTIONS

DESCRIZIONE / DESCRIPTION	COLORE / COLOR
U - FASE MOTORE / MOTOR PHASE	MARRONE / BROWN
V - FASE MOTORE / MOTOR PHASE	BLU / BLUE
W - FASE MOTORE / MOTOR PHASE	NERO / BLACK

CONNESSIONI ELETTRICHE DI SEGNALE / SIGNAL ELECTRIC CONNECTIONS

PIN	DESCRIZIONE / DESCRIPTION	COLORE / COLOR
1	NON COLLEGATO	-
2	NON COLLEGATO	-
3	SONDA TERMICA STATORE / BI-METALLIC STATOR THERMAL SWITCH	GIALLO / YELLOW
4	SONDA TERMICA STATORE / BI-METALLIC STATOR THERMAL SWITCH	GIALLO / YELLOW