

ATTACCO ISO30 DIN 69871-1
TOOL INTERFACE ISO30 DIN 69871-1

CONNETTORE SEGNALE I/O - SIGNAL I/O CONNECTOR
CONNETTORE CIRCOLARE M23 SEGNALE 17 VIE
CIRCULAR CONNECTOR M23 SIGNAL 17 CONTACTS

SOFFIO CONO: E6 ARIA SECCA 6 - 6,5 BAR
TAPER CLEANING: E6 AIR DRY 6 - 6,5 BAR

BLOCCO UTENSILE: E4 ARIA SECCA 6 - 6,5 BAR
LOCK TOOL: E4 AIR DRY 6 - 6,5 BAR

SBLOCCO UTENSILE: E6 ARIA SECCA 6 - 6,5 BAR
RELEASE TOOL: E6 AIR DRY 6 - 6,5 BAR

CONNETTORE POTENZA - POWER CONNECTOR
CONNETTORE CIRCOLARE M23 POTENZA 4+4 VIE
CIRCULAR CONNECTOR M23 POWER 4+4 CONTACTS

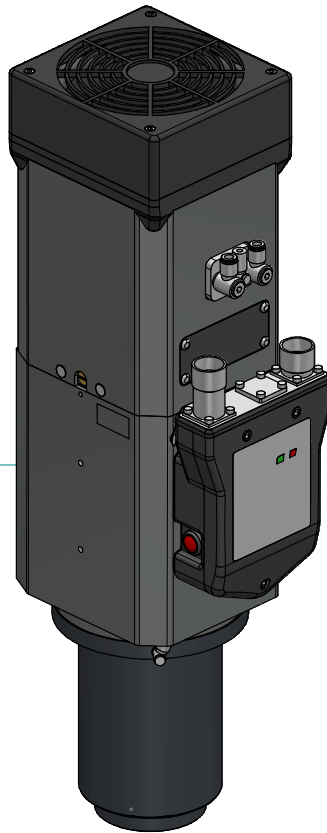
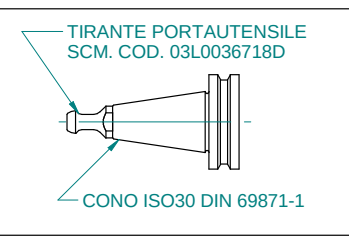
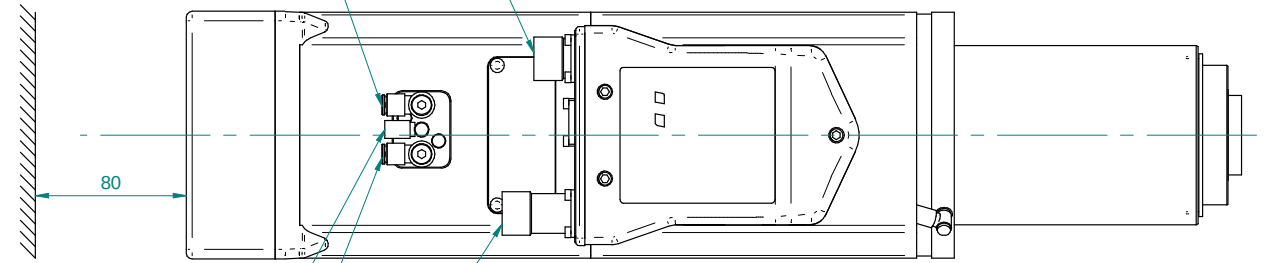
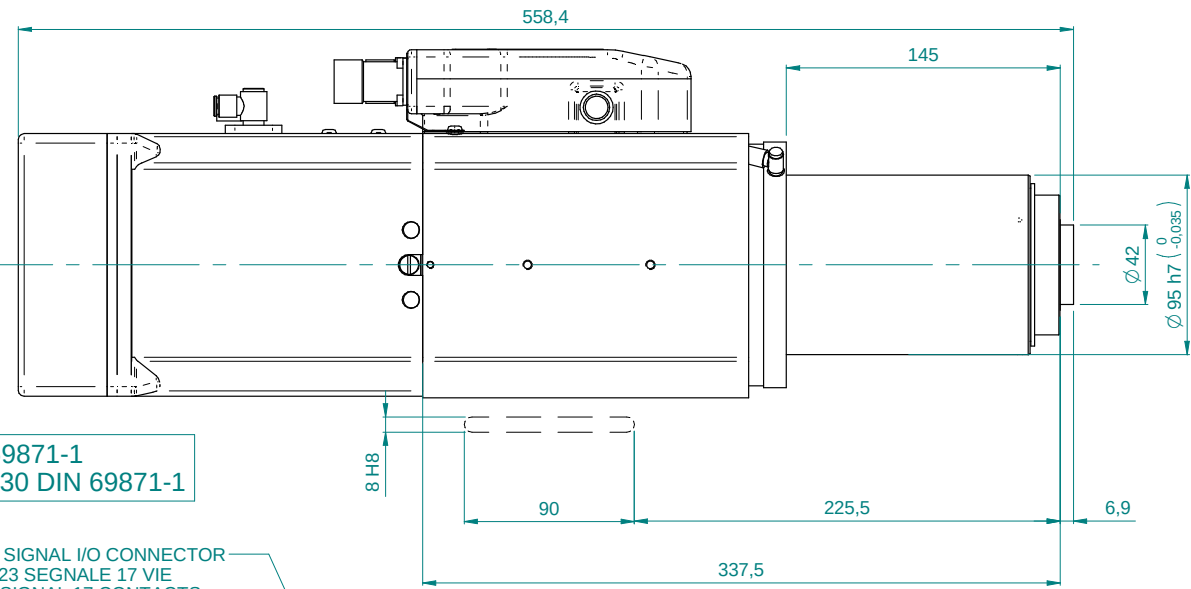

PUNZONARE SU CARCASSA:

EI XXXX
YY/ZZ

XX=SERIALE
YY=MESE DI PROD.
ZZ=ANNO DI PROD.

Massa: 23 Kg

01							
Rev	Data / Date	Firma / Signature	Descrizione ultima modifica / Last change description			N° Modifica / Change ID	
Caratteristiche tecniche non esecutive secondo relazione operativa SCM GROUP - ID: 231010		Specificatore, per favore according to SCM GROUP operation instruction - ID: 231010			Verniciatura / Painting (SCM specific ST2310TG)		
Ultima uscita secondo specifica SCM (revisione esecutiva) - ID: 231010		Firma / Signature			Superficie / Surface (m²)		
Firma / Signature		Data / Date		Rugosità / Roughness		Trattamento Superficiale / Surface Treatment (SCM specific ST234DTG)	
Ultimo rilascio / Latest release						Trattamento Termico / Heat Treatment (SCM specific ST234DTG)	
Controllato / Checker			Peso grezzo/Raw weight (kg)	Ricaricare da o Stato di fornitura / Based on or State of supply			
Disegnato / Designed	L.Guiducci	22/02/2016	Smussi / chamfer	Massa / Mass (kg)	27,031	Materiale / Material (SCM specific ST235DTG)	
			Denominazione / Item Name		Vedi Tabella		
			ELETM QE-1F 6.6/12 24 I30 NL CC DV				
			Scala / Scale		1:2		
			Codice / Item ID		QE.300.A26.00		
			Rev		00		
			Status				
			Tav. N. di N.		1/1		