

ATTACCO HSK 63F DIN69893-6
TOOL INTERFACE HSK 63F DIN 69893-6

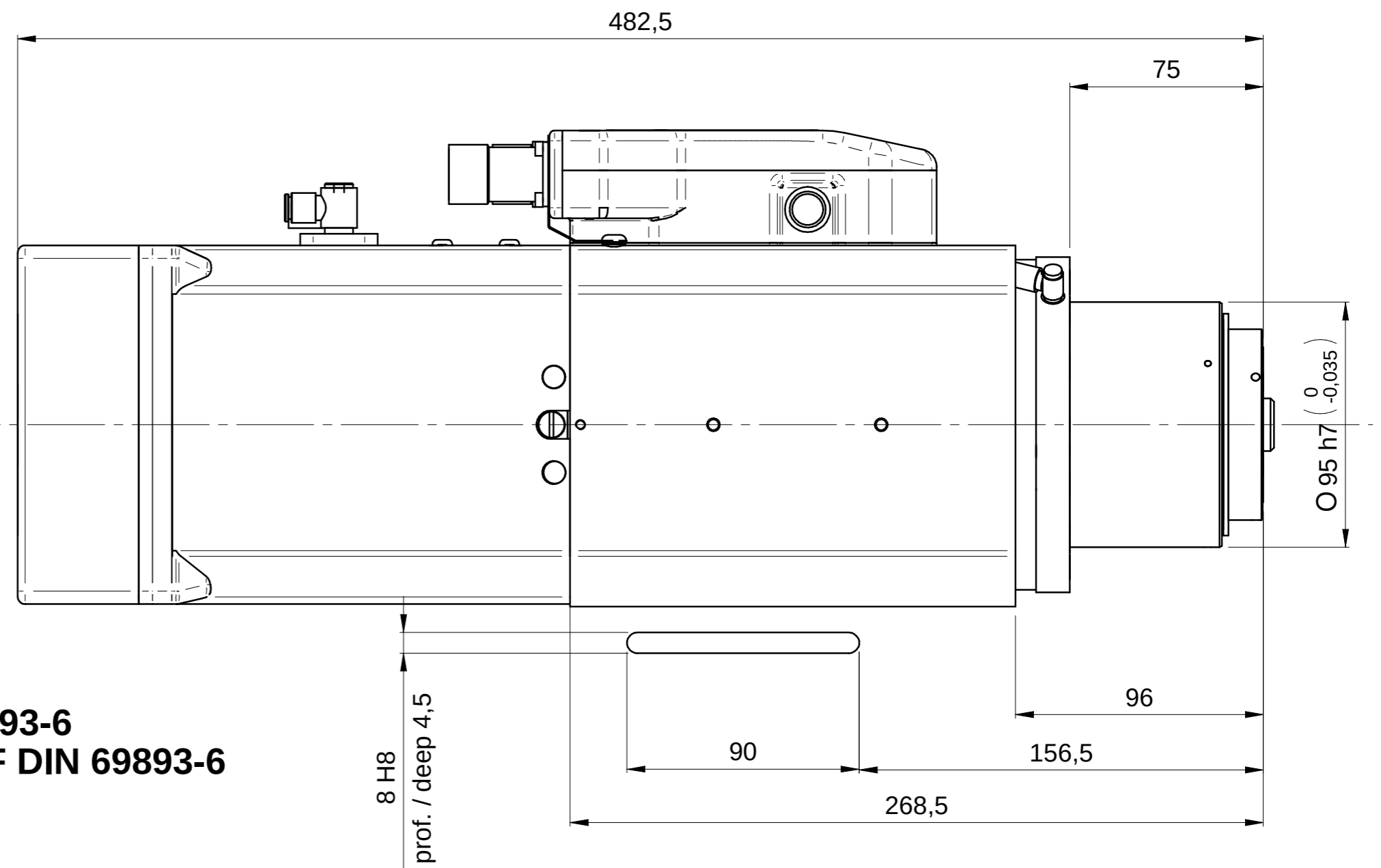

SOFFIO CONO: E6 ARIA SECCA 6 bar
TAPPER CLEANING E6 AIR DRY 6 bar

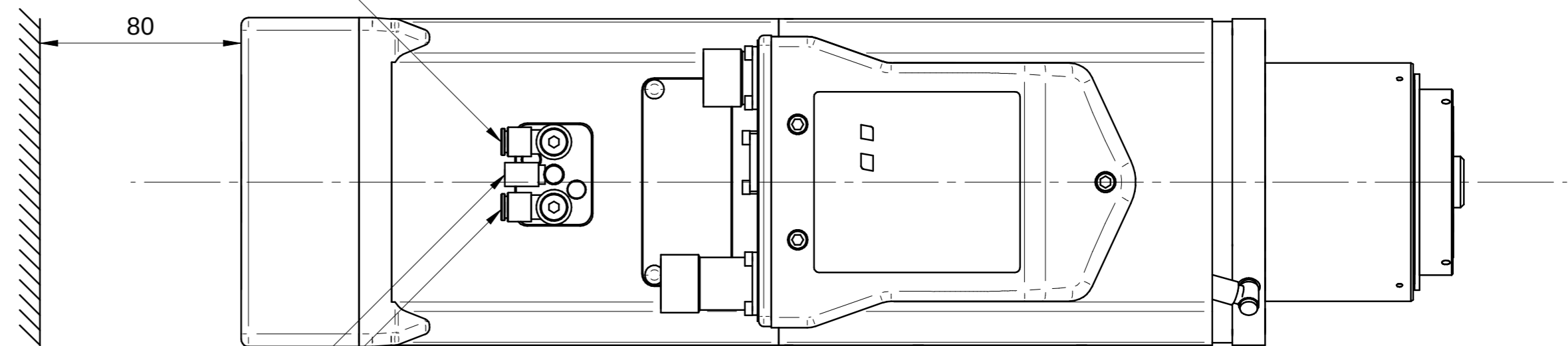

BLOCCO UTENSILE: E4 ARIA SECCA 6 bar
LOCK TOOL : E4 AIR DRY 6 bar

SBLOCCO UTENSILE: E6 ARIA SECCA 6 bar
RELEASE TOOL: E6 AIR DRY 6 bar

Massa: 23 Kg

PUNZONARE SU CARCASSA:

EQ XXXX
YY/ZZ

XX=SERIALE
YY=MESE DI PRODUZIONE
ZZ=ANNO SI PRODUZIONE

01									
Rev	Data / Date	Firma / Signature	Descrizione ultima modifica / Last change description			N° Modifica / Change ID			
			Caratteristiche tecniche non evidenziate secondo istruzioni operative SCM GROUP : IO 231D1TG Specifications not shown according to SCM GROUP operation instruction : IO 231D1TG			Verniciatura / Painting (SCM specific ST231D1TG)		Superficie / Surface (m²)	
			Strutture saldate secondo specifica SCM / Welded according to SCM specific : ST232D1G			Trattamento Superficiale / Surface Treatment (SCM specific ST234D1G)			
			Finiture secondo specifica SCM / Finishes secondo SCM specific : ST233D1G			Trattamento Termico / Heat Treatment (SCM specific ST234D1G)			
			Quote senza indicazione di tolleranza, grado di precisione Shares without indication of tolerance, accuracy			SCM Specifica ST2310D1G			
Ultimo rilascio Latest release			Rugosità / Roughness						
Controllato Checked			CF3	0	Peso grezzo/Raw weight (kg)	Ricavare da o Stato di fornitura / Based on or State of supply			
Disegnato Designed	G.Franchino	16/09/2016	Smussi / chamfer		Massa / Mass (kg)	25,897	Materiale / Material (SCM specific ST235D1G) Vedi Tabella		
HITECO		HIGH TECHNOLOGY COMPONENTS		Denominazione / Item Name		ELETM QE-1F 8/12 24 63F NC CC DV			
		Scala / Scale		Codice / Item ID		Rev		Status	
		1:2		QE.300.A30.00		01		Tav. N. di N. 1/1	
<small> Template version: 12 CI RISERVIAMO A TERMINI DI LEGGE LA PROPRIETA' DI QUESTO DISEGNO CON DIVIETO DI RENDERSI COMUNIQUE NOTO A TERZI SENZA LA NOSTRA PREVENTIVA APPROVAZIONE. DRAWING IS SCM PROPERTY. COPYRIGHTED MATERIAL. DISCLOSURE TO THIRD PARTIES WITHOUT OUR AUTHORISATION IS EXPLICITLY FORBIDDEN. </small>									